



City of Chicago



O2018-8490

Office of the City Clerk

Document Tracking Sheet

Meeting Date:	10/31/2018
Sponsor(s):	Hopkins (2)
Type:	Ordinance
Title:	Grant(s) of privilege in public way for One Superior Place
Committee(s) Assignment:	Committee on Transportation and Public Way

ORDINANCE
ONE SUPERIOR PLACE
Acct. No. 401670 - 1
Permit No. 1134071

Be It Ordained by the City Council of the City of Chicago:

SECTION 1. Permission and authority are hereby given and granted to ONE SUPERIOR PLACE, upon the terms and subject to the conditions of this ordinance to maintain and use one (1) sign(s) projecting over the public right-of-way attached to its premises known as 1 W. Superior St..

Said sign structure(s) measures as follows; along W Superior St:

One (1) at twenty-seven point two five (27.25) feet in length, two point zero eight (2.08) feet in height and fourteen (14) feet above grade level.

The location of said privilege shall be as shown on prints kept on file with the Department of Business Affairs and Consumer Protection and the Office of the City Clerk.

Said privilege shall be constructed in accordance with plans and specifications approved by the Department of Transportation (Division of Project Development) and Zoning Department - Signs.

This grant of privilege in the public way shall be subject to the provisions of Section 10-28-015 and all other required provisions of the Municipal Code of Chicago.

The grantee shall pay to the City of Chicago as compensation for the privilege #1134071 herein granted the sum of three hundred (\$300.00) per annum in advance.

A 25% penalty will be added for payments received after due date.

The permit holder agrees to hold the City of Chicago harmless for any damage, relocation or replacement costs associated with damage, relocation or removal of private property caused by the City performing work in the public way.

Authority herein given and granted for a period of five (5) years from and after Date of Passage.

Alderman _____

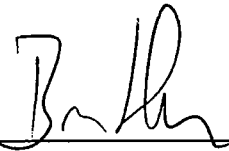

Brian Hopkins 2nd Ward

INTERNALLY-ILLUMINATED SIGN CABINET W/ 3/4" ACRYLIC PUSH-THRU LETTERING

Illuminated acrylic push thru letters
on 2 deep aluminum cabinet

WEST ELEVATION

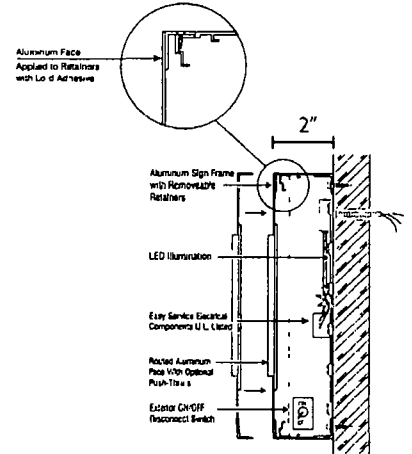
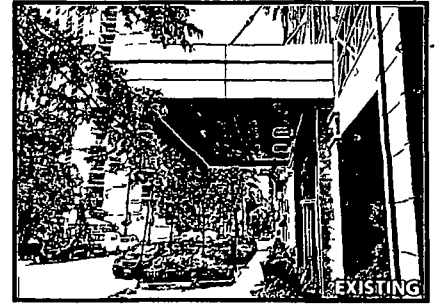
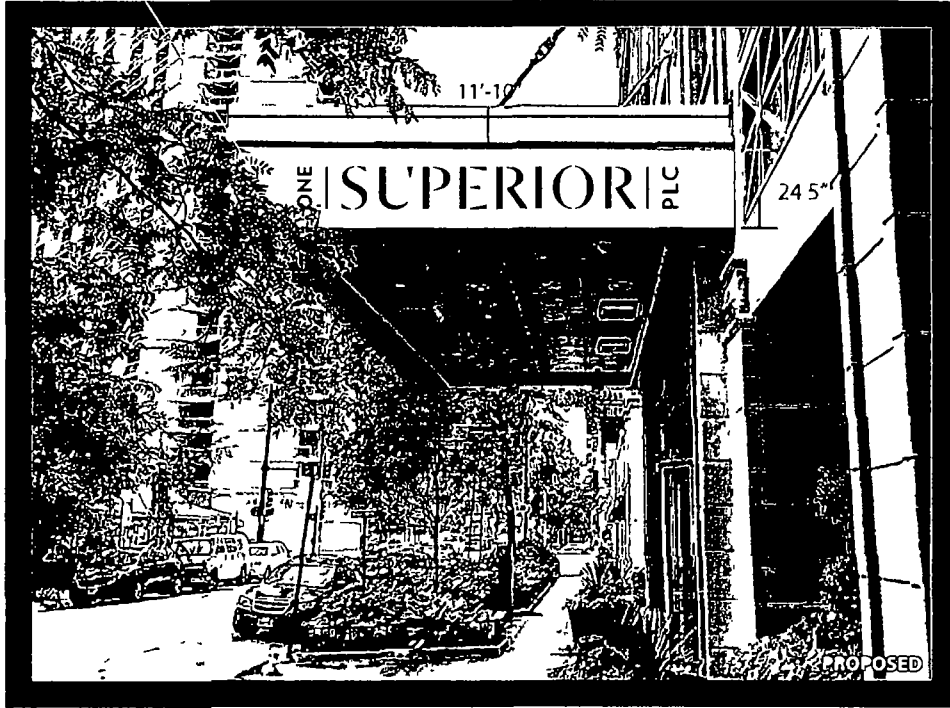

2 DEEP ALUMINUM SIGN CABINET
W/ 3/4" CLEAR ACRYLIC PUSH THRU
CONNECTING TO EXISTING CUSTOMER LEADS
ALL FASTENERS NON CORROSIVE



COMETNEON
SIGN AND AWNING

1120 N Ridge Ave
Lombard IL 60148
Phone (630) 656 1085
Fax (630) 656 1088
permits@cometneon.com
www.cometneon.com

Client Name One Superior Place
Location 1 W Superior St
Chicago IL 60654

Start Date 5/29/18
Drawn By Marcin Wolak
Job# N/A
Drawing# N/A
Page 1 of 1

Client Approval
Landlord Approval



Department of Business Affairs and Consumer Protection
Small Business Center - Public Way Use Unit
City Hall - 121 N LaSalle Street, Room 800 • Chicago, IL 60602
312-74-GOBIZ // 312-744-6249 • (312) 744-1944 (TTY)
<http://www.cityofchicago.org/bacp>

10/31/2018

Alderman **Brian Hopkins**
Ward # **02**
City of Chicago
City Hall, Room **200**
121 North LaSalle Street
Chicago, Illinois 60602

Re: An ordinance to use and maintain a portion of the public right-of-way for **one (1) sign(s)** for **ONE SUPERIOR PLACE**, adjacent to the premises known as **1 W. Superior St.**

Dear Alderman **Brian Hopkins**:

The applicant referenced above has requested the use of the public right-of-way for a **sign(s)**. An ordinance has been prepared by the Department of Business Affairs and Consumer Protection – Small Business Center - Public Way Use Unit for presentation to the City Council. Because this request was made for properties located in your ward, as approved by you as per the attached, I respectfully request that you introduce the attached ordinance at the next City Council meeting.

If you have any questions regarding this ordinance, please contact Anthony Bertuca at (312) 744-5506.

Department of Business Affairs and Consumer Protection