



City of Chicago



O2014-7581

Office of the City Clerk

Document Tracking Sheet

Meeting Date:	9/10/2014
Sponsor(s):	Smith (43)
Type:	Ordinance
Title:	Awning(s) for Lou Malnati's Pizzeria
Committee(s) Assignment:	Committee on Transportation and Public Way

ORDINANCE
Lou Malnati's Pizzeria
Acct. No. 50161 - 2
Permit No. 1114671

Be It Ordained by the City Council of the City of Chicago:

SECTION 1. Permission and authority are hereby given and granted to Lou Malnati's Pizzeria, upon the terms and subject to the conditions of this ordinance to maintain and use, as now constructed, nine (9) Awning(s) projecting over the public right-of-way adjacent to its premises known as 958 W. Wrightwood Ave..

Said Awning(s) at WEST WRIGHTWOOD measure(s):

One (1) at seven point nine two (7.92) feet in length, and three (3) feet in width for a total of twenty-three point seven six (23.76) square feet.

One (1) at seven point nine two (7.92) feet in length, and three (3) feet in width for a total of twenty-three point seven six (23.76) square feet.

One (1) at eight point six seven (8.67) feet in length, and three (3) feet in width for a total of twenty-six point zero one (26.01) square feet.

One (1) at five point one seven (5.17) feet in length, and three (3) feet in width for a total of fifteen point five one (15.51) square feet.

One (1) at seven point eight three (7.83) feet in length, and three (3) feet in width for a total of twenty-three point four nine (23.49) square feet.

Two (2) at four (4) feet in length, and three (3) feet in width for a total of twenty-four (24) square feet.

One (1) at seven point zero eight (7.08) feet in length, and three (3) feet in width for a total of twenty-one point two four (21.24) square feet.

One (1) at sixteen point three three (16.33) feet in length, and three (3) feet in width for a total of forty-eight point nine nine (48.99) square feet.

The location of said privilege shall be as shown on prints kept on file with the Department of Business Affairs and Consumer Protection and the Office of the City Clerk.

Said privilege shall be constructed in accordance with plans and specifications approved by the Zoning Department - Signs.

This grant of privilege in the public way shall be subject to the provisions of Section 10-28-015 and all other required provisions of the Municipal Code of Chicago.

The grantee shall pay to the City of Chicago as compensation for the privilege #1114671 herein granted the sum of one hundred seventy-five (\$175.00) per annum in advance.

A 25% penalty will be added for payments received after due date.

The permit holder agrees to hold the City of Chicago harmless for any damage, relocation or replacement costs associated with damage, relocation or removal of private property caused by the City performing work in the public way.

Authority herein given and granted for a period of five (5) years from and after 07/26/2014.

Alderman 

Michele Smith 43rd Ward

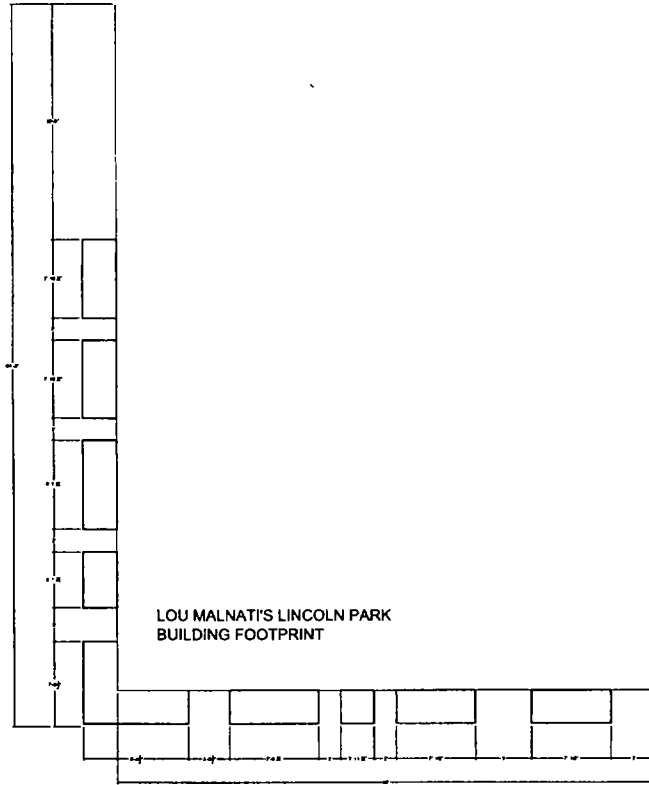

LOU MALNATI'S LINCOLN
PARK AWNING LOCATIONS
SCALE: $\frac{1}{8}'' = 1'-0''$

Job # 722115
Lou Malnati's

West elev. location	width
A	7'-10 ³ / ₄ "
B	7'-10 ¹ / ₄ "
C	8'-7 ³ / ₄ "
D	5'-1 ³ / ₄ "
Corner	see plan
South elev.	
E	7'-9 ³ / ₄ "
F	3'-11 ³ / ₄ "
G	7'-0 ¹ / ₂ "
H	7'-0 ¹ / ₂ "

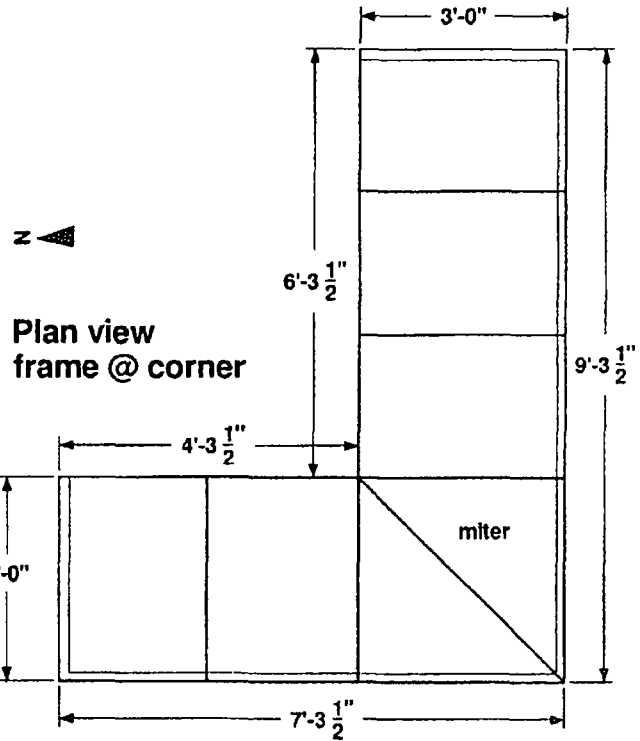
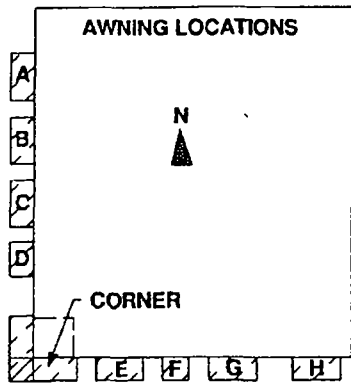

DETAIL

ATTACHMENT @ WALL (TOP)

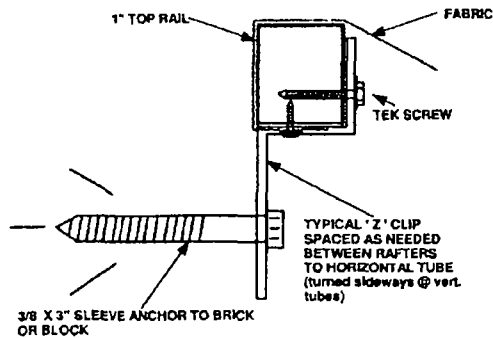

Iso view, frame

