



# City of Chicago



O2020-5476

Office of the City Clerk

## Document Tracking Sheet

<b>Meeting Date:</b>	11/16/2020
<b>Sponsor(s):</b>	Nugent (39)
<b>Type:</b>	Ordinance
<b>Title:</b>	Awning(s) for My Sister's Closet
<b>Committee(s) Assignment:</b>	Committee on Transportation and Public Way

ORDINANCE  
MY SISTER'S CLOSET  
Acct No 50460 - 3  
Permit No. 1146901

*Be It Ordained by the City Council of the City of Chicago:*

SECTION 1. Permission and authority are hereby given and granted to MY SISTER'S CLOSET, upon the terms and subject to the conditions of this ordinance to maintain and use, as now constructed, two (2) Awning(s) projecting over the public right-of-way adjacent to its premises known as 5413-5417 W. Devon Ave..

Said Awning(s) at W Devon Ave measure(s):

One (1) at fourteen point two five (14.25) feet in length, and three (3) feet in width for a total of forty-two point seven five (42.75) square feet

One (1) at eight point eight three (8.83) feet in length, and three (3) feet in width for a total of twenty-six point four nine (26.49) square feet

The location of said privilege shall be as shown on prints kept on file with the Department of Business Affairs and Consumer Protection and the Office of the City Clerk.

Said privilege shall be constructed in accordance with plans and specifications approved by the Zoning Department - Signs.

This grant of privilege in the public way shall be subject to the provisions of Section 10-28-015 and all other required provisions of the Municipal Code of Chicago.

The grantee shall pay to the City of Chicago as compensation for the privilege #1146901 herein granted the sum of one hundred (\$100.00) per annum in advance.

A 25% penalty will be added for payments received after due date.

The permit holder agrees to hold the City of Chicago harmless for any damage, relocation or replacement costs associated with damage, relocation or removal of private property caused by the City performing work in the public way.

Authority herein given and granted for a period of five (5) years from and after 04/15/2020.

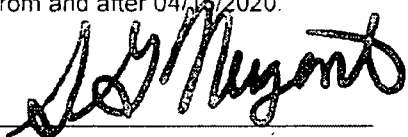
Alderman   
Samantha Nugent 39th Ward

1

Side view, (on 2)

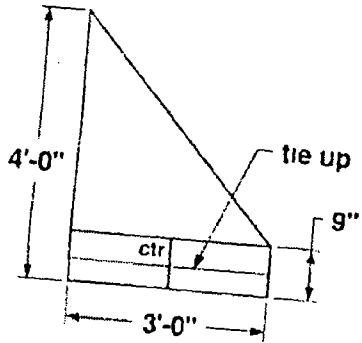

JOB # 724805  
My Sister's Closet

- Notes
- alum frames (2)
  - silver frame finish
  - tubing as noted
  - tie bar up
  - 2 adj pushes

Iso view, 101

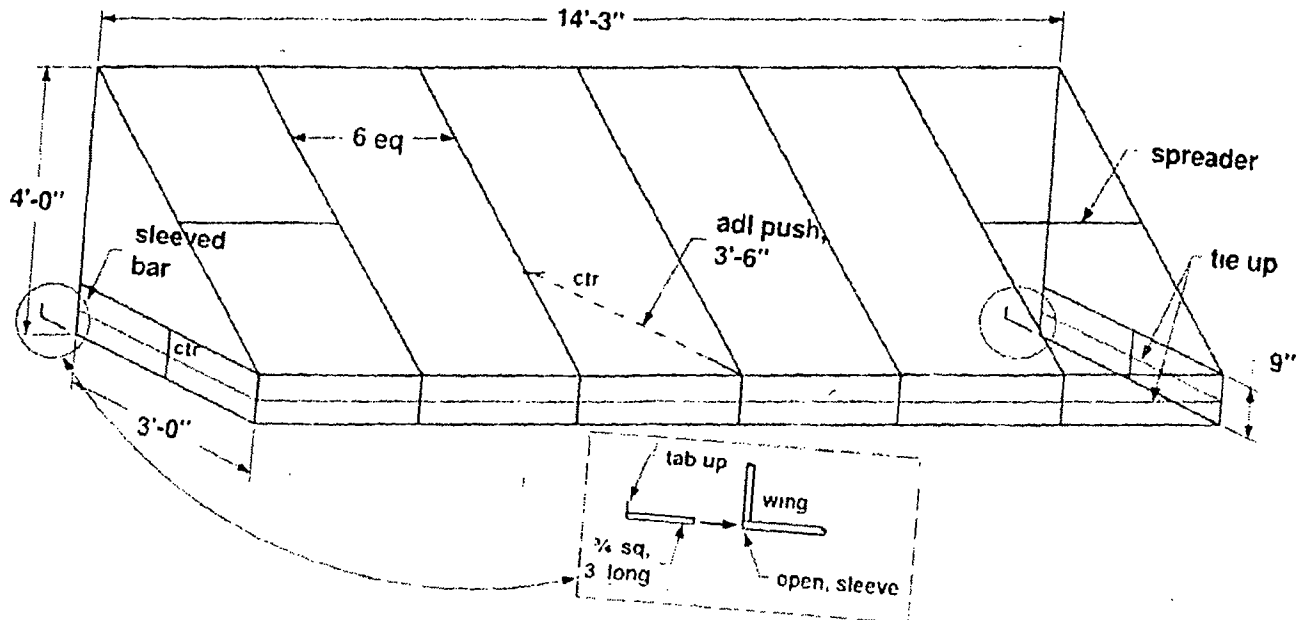



Department of Business Affairs and Consumer Protection  
Small Business Center - Public Way Use Unit  
City Hall - 121 N. LaSalle Street, Room 800 • Chicago, IL 60602  
312-74-GOBIZ / 312-744-6249 • (312) 744-1944 (TTY)  
<http://www.cityofchicago.org/bocp>

11/16/2020

Alderman **Samantha Nugent**  
Ward # 39  
City of Chicago  
City Hall, Room 200  
121 North LaSalle Street  
Chicago, Illinois 60602

Re: An ordinance to use and maintain a portion of the public right-of-way for **two (2) awning(s)** for **MY SISTER'S CLOSET**, adjacent to the premises known as **5413-5417 W. Devon Ave.**.

Dear Alderman **Samantha Nugent**:

The applicant referenced above has requested the use of the public right-of-way for a **awning(s)**. An ordinance has been prepared by the Department of Business Affairs and Consumer Protection – Small Business Center - Public Way Use Unit for presentation to the City Council. Because this request was made for properties located in your ward, as approved by you as per the attached, I respectfully request that you introduce the attached ordinance at the next City Council meeting.

If you have any questions regarding this ordinance, please contact Anthony Bertuca at (312) 744-5506.

Department of Business Affairs and Consumer Protection