



# City of Chicago



Or2013-223

Office of the City Clerk

## Document Tracking Sheet

<b>Meeting Date:</b>	5/8/2013
<b>Sponsor(s):</b>	Maldonado, Roberto (26)
<b>Type:</b>	Order
<b>Title:</b>	Issuance of permits for sign(s)/signboard(s) at 4243 W North Ave, 1st Fl.
<b>Committee(s) Assignment:</b>	Committee on Zoning, Landmarks and Building Standards

City Council, meeting date: May 8, 2013  
Committee on Zoning, Landmarks, & Building Standards

ORDERED, That the Commissioner of the Building Department is hereby directed to issue a sign permit to:

**Darryl Brown**  
**4243 W. North Avenue**

For the erection of a sign/signboard over twenty-four (24) feet in height and/or over one hundred (100 square feet (in area of one face) at:

On-Premise/Business ID signs: **Joyful Noise Christian Day Care**  
**4243 W. North Avenue, 1<sup>st</sup> Floor**  
**Chicago, IL 60639**

Dimensions: Length 40 ft.; Height 5 ft.; Depth 2 ft.

Height above grade: 9.5 ft.

Such signs shall comply with all provisions of Title 17 of the Chicago Zoning Ordinance and all other applicable provisions of the Municipal Code of the City of Chicago governing the construction and maintenance of outdoor signs, sign boards, and structures.

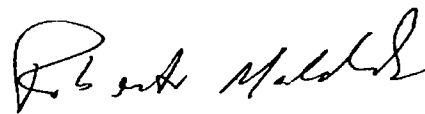

---

Alderman, 26<sup>th</sup> Ward

# APPLICATION TO USE THE PUBLIC RIGHT OF WAY



## APPLICANT INFORMATION

LEGAL NAME OF ENTITY: Joyful Noise Christian Daycare

PERMIT MAILING ADDRESS: 4243 W. North Ave.

CITY: Chicago STATE ILLINOIS ZIP CODE 60639

CONTACT PERSON: DARRYL BROWN TITLE Supervisor

PHONE: 773-297-5981 FAX: 773-252-2340 E-MAIL: WWW-Joyfulnoise-

email: joyfulnoise@daycare@360global.net christiandaycare.com

## USE OF THE PUBLIC WAY

1. List the proposed or existing use below and complete the worksheet on page 3  
Use only one application per public way use type

TYPE	HOW MANY?	BUILDING ADDRESS
<u>CANOPY</u>	<u>1</u>	<u>4243 W. North Ave.</u>

2. Please enclose one sketch of proposed use of the public way, which maps to scale the proposed use and its relationship to surrounding right-of-way. All measurements must be indicated

The prints should also accurately depict the location of the property line and public facilities (meters, light poles, sidewalks).

## APPLICANT CERTIFICATION

I hereby certify that all statements made as part of the application, and the attachments herein, are true to the best of my knowledge and belief.

BY: Darryl Brown TITLE: SUPERVISOR

F.E.I.N. or SOCIAL SECURITY NUMBER: \_\_\_\_\_

## ALDERMAN'S APPROVAL

As part of this application process, you are required to notify/obtain approval from the Alderman in whose ward your proposed use of the public way is located.

ALDERMAN'S SIGNATURE \_\_\_\_\_ WARD \_\_\_\_\_ DATE \_\_\_\_\_  
x Robert Malbran 26th 4.1.13



City of Chicago | Department of Business Affairs and Consumer Protection | Public Way Use Unit  
Business Assistance Center | City Hall, Room 800 | 121 North LaSalle Street | Chicago, Illinois 60602  
www.cityofchicago.org/bcap | 312.74.GOBIZ (744.6249) | 312.742.1974 (TTY)

Scale: 1mm = 4 inches

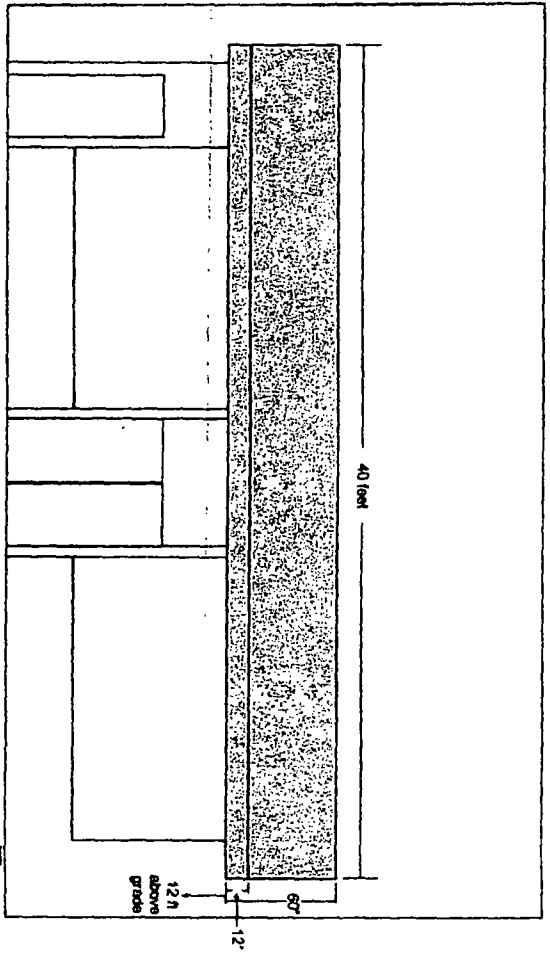

Joyful Noise Christian Daycare Inc  
4243 W North Ave  
Chicago, IL 60639

11'6" Curb to building  
NORTH AVE

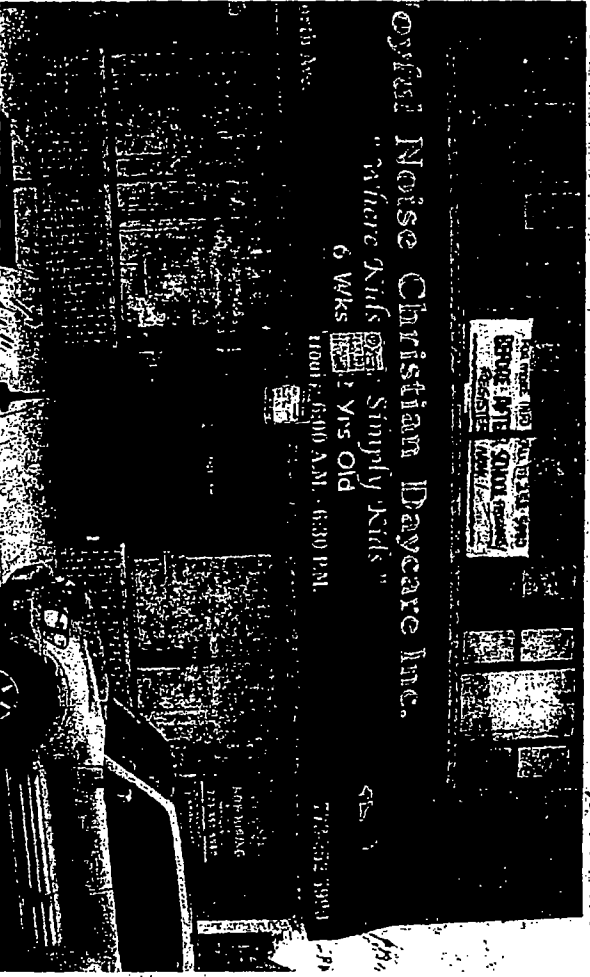

Brick Wall

Bolted into  
brick wall  
w/ 3/8" x 4" lags  
every 80 inches

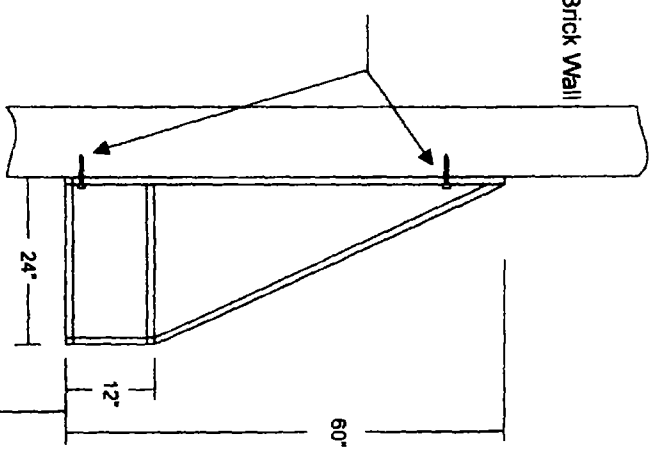

Scale: 1mm = 1 inch

11'6" Bldg to Curb  
NORTH AVE

ASAP Sign & Lighting Maintenance, Inc  
443 W US Hwy 6  
Valparaiso, IN 46385-7936

Ken Richmond  
312-718-8819 219-464-8865

# APPLICATION TO USE THE PUBLIC RIGHT OF WAY



## EXAMPLE OF SIGN DRAWING

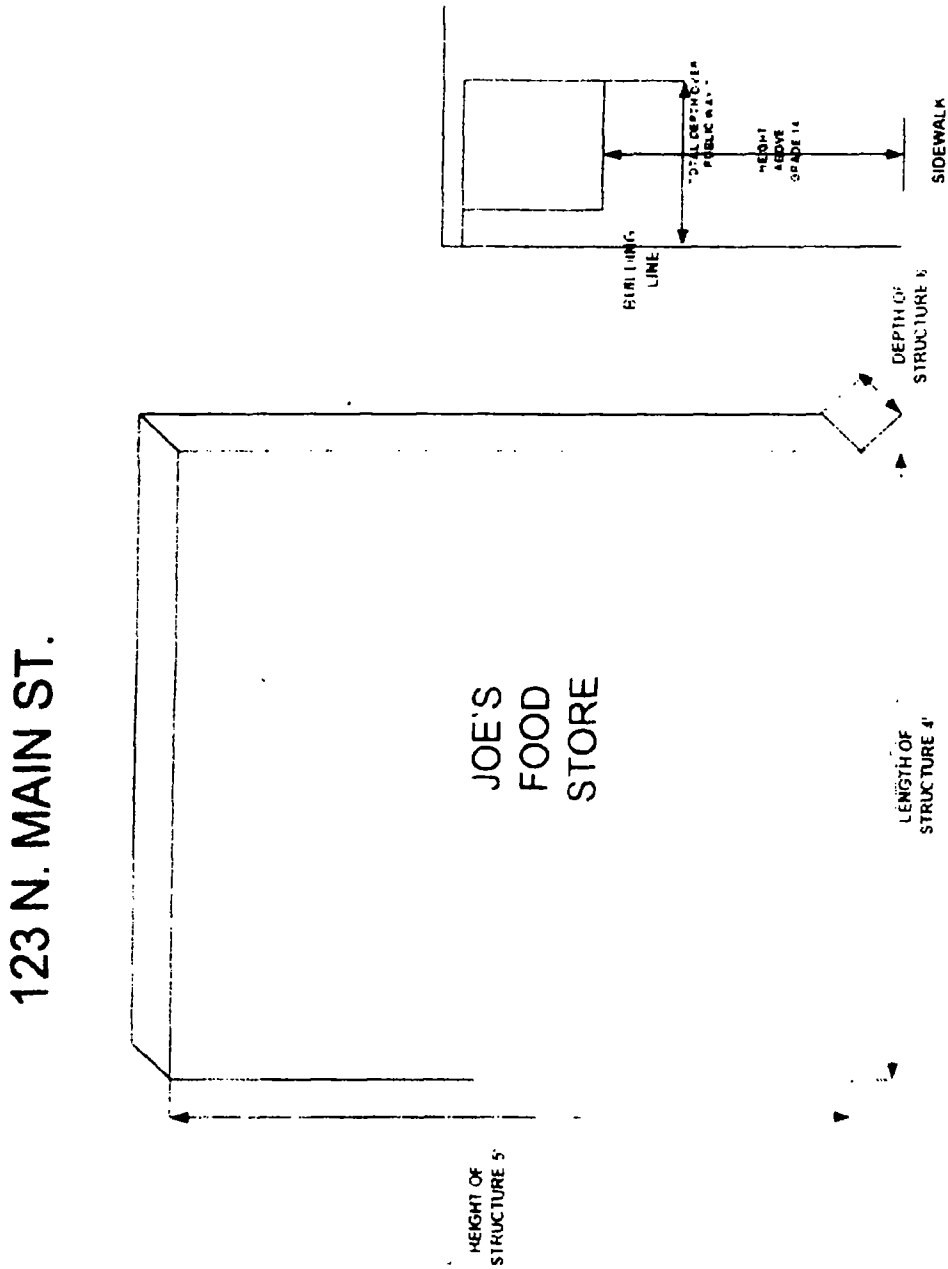

City of Chicago | Department of Business Affairs and Consumer Protection | Public Way Use Unit  
Business Assistance Center | City Hall, Room 800 | 121 North LaSalle Street | Chicago, Illinois 60602  
[www.cityofchicago.org/bacp](http://www.cityofchicago.org/bacp) | 312.74.GOBIZ (744.6249) | 312.742.1974 (TTY)

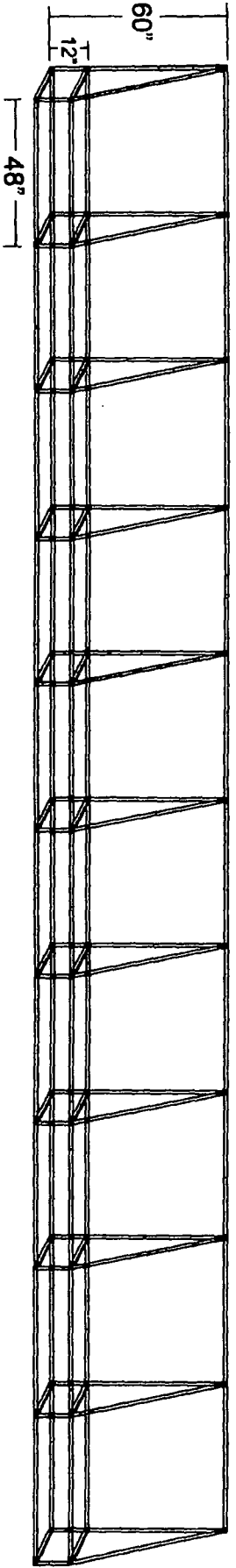
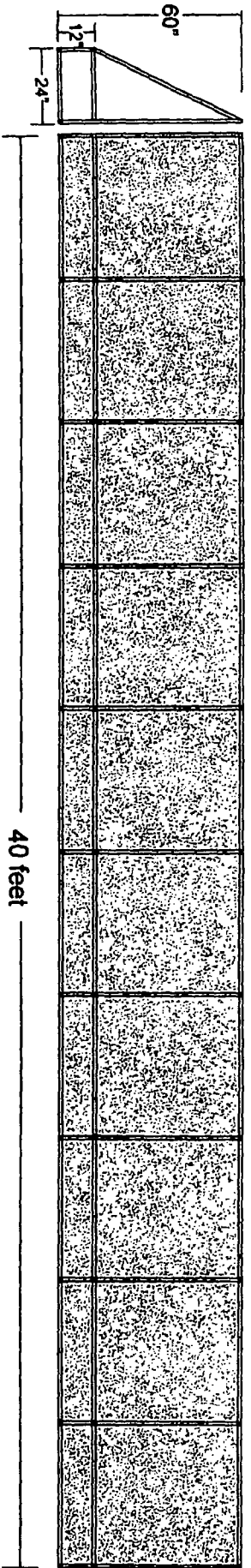

scale 1mm = 2 inches

All structure and supports are  
 1 x 1 x .063 Tuffac Galvanized tubing construction  
 48 inch center and back supports

Joyful Noise Christian Daycare  
 4243 W North Ave  
 Chicago, IL 60639

ASAP Sign & Lighting Maintenance, Inc  
 443 W US Hwy 6  
 Valparaiso, IN 46385-7936

Ken Richmond  
 312-718-8819 219-464-8865

Scale: 1mm = 4 inches

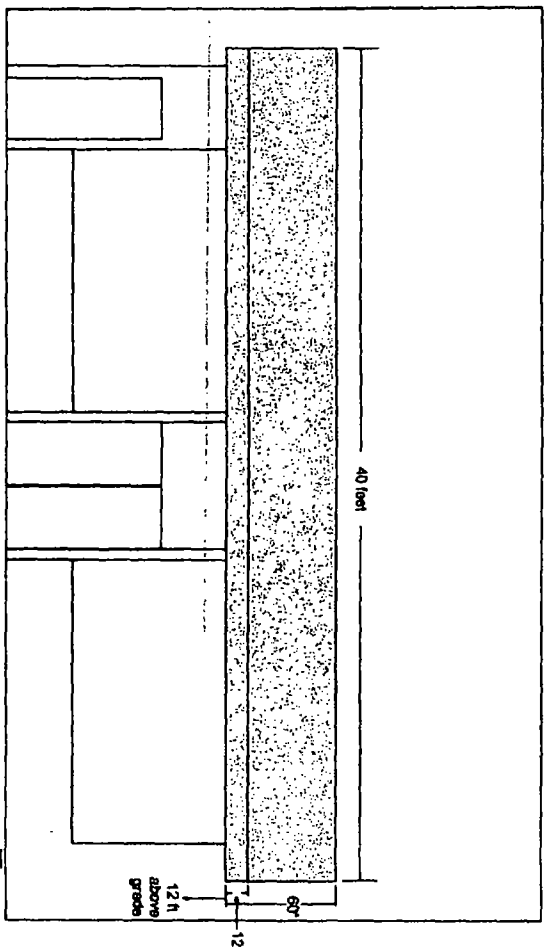

Joyful Noise Christian Daycare Inc  
4243 W North Ave  
Chicago, IL 60639

11'6" Curb to building  
NORTH AVE

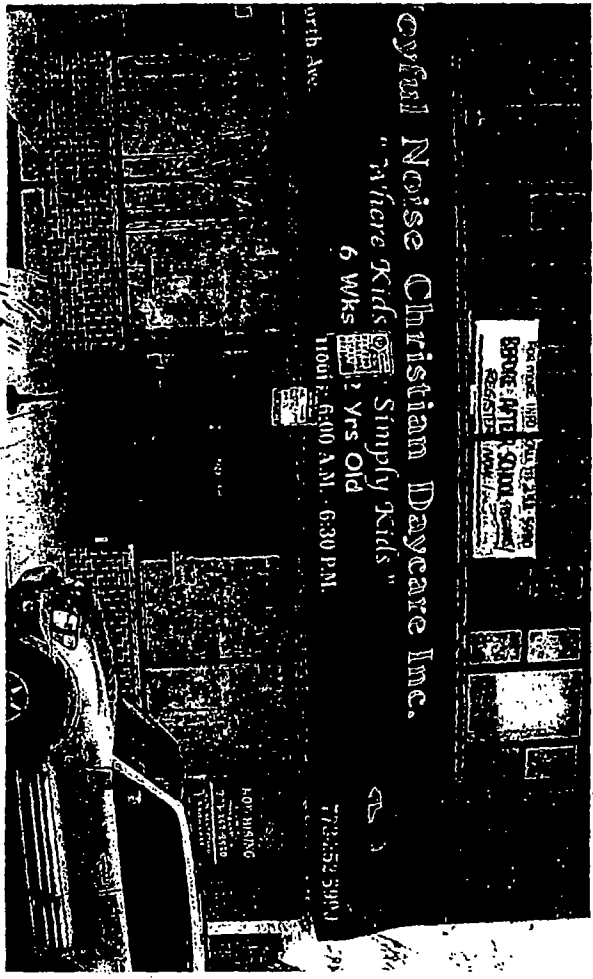

Bolled into brick wall w/ 3/8 x 4" lags every 60 inches

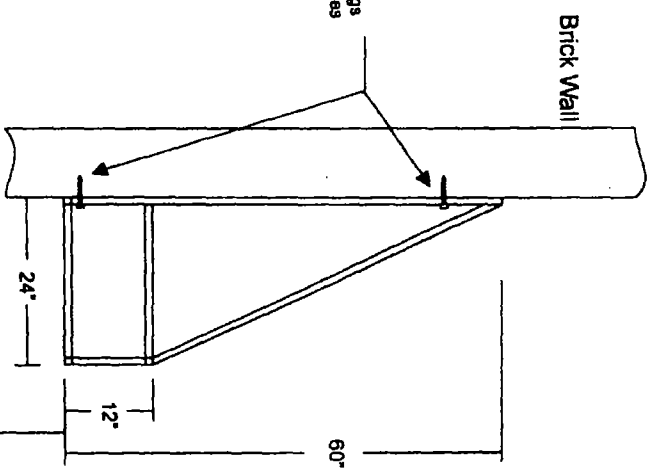

Scale: 1mm = 1 inch

11'6" Bldg to Curb  
NORTH AVE

ASAP Sign & Lighting Maintenance, Inc  
443 W US Hwy 6  
Valparaiso, IN 46385-7936  
Ken Richmond  
312-718-8819 219-464-8865

4544 N Broadway  
Chicago, IL 60640  
Tel: 773-878-4646  
Fax: 773-878-4920  
info@james46.org

## CERTIFICATION

To be completed by business owner/manager:

*I hereby certify that all statements made as part of this application and any attachments herein, are true to the best of my knowledge and belief. I also understand that a standing/loading zone ordinance is introduced to the City Council at the discretion of 46th Ward Alderman James Cappleman – submission of this application does not guarantee the granting of a standing/loading zone. The analysis of this application will weigh the benefits of placing the zone adjacent to my business versus the disadvantages of the reduction of available street parking in the area. I acknowledge that the issuance of a standing/loading zone is a privilege granted by the City of Chicago and not a right of my business ownership – the curb lane is and shall remain the property of the City. I agree to accept the decision of the Alderman to partially or fully accept, or deny my application.*

*Furthermore, I agree to follow all applicable laws as outlined by the Municipal Code of the City of Chicago, and requirements as put forth in this application and by the Committee on Traffic Control and Safety, the Department of Transportation, and the Department of Revenue. I also understand that the standing/loading zone may be removed at the Alderman's discretion or at the urging of any City Department.*

Signature: \_\_\_\_\_

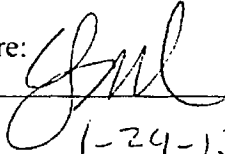

Date: \_\_\_\_\_

1-24-13

Print Name: \_\_\_\_\_

Andy Monk

Title: \_\_\_\_\_

Property Manager