



City of Chicago



O2014-364

Office of the City Clerk

Document Tracking Sheet

| | |
|---------------------------------|--|
| Meeting Date: | 1/15/2014 |
| Sponsor(s): | Burns (4) |
| Type: | Ordinance |
| Title: | Grant(s) of privilege in public way for Lake Park Associates |
| Committee(s) Assignment: | Committee on Transportation and Public Way |

ORDINANCE
Lake Park Associates
Acct. No. 379530 - 7
Permit No. 1109485

Be It Ordained by the City Council of the City of Chicago:

SECTION 1. Permission and authority are hereby given and granted to Lake Park Associates, upon the terms and subject to the conditions of this ordinance to maintain and use one (1) sign(s) projecting over the public right-of-way attached to its premises known as 1411 E. 53rd St..

Said sign structure(s) measures as follows; along 53rd Street:
One (1) at three (3) feet in length, two (2) feet in height and eleven point eight three (11.83) feet above grade level.

The location of said privilege shall be as shown on prints kept on file with the Department of Business Affairs and Consumer Protection and the Office of the City Clerk.

Said privilege shall be constructed in accordance with plans and specifications approved by the Department of Transportation (Division of Project Development) and Zoning Department - Signs.

This grant of privilege in the public way shall be subject to the provisions of Section 10-28-015 and all other required provisions of the Municipal Code of Chicago.

The grantee shall pay to the City of Chicago as compensation for the privilege #1109485 herein granted the sum of one hundred (\$100.00) per annum in advance.

A 25% penalty will be added for payments received after due date.

The permit holder agrees to hold the City of Chicago harmless for any damage, relocation or replacement costs associated with damage, relocation or removal of private property caused by the City performing work in the public way.

Authority herein given and granted for a period of five (5) years from and after Date of Passage.

Alderman 

William D. Burns 4th Ward

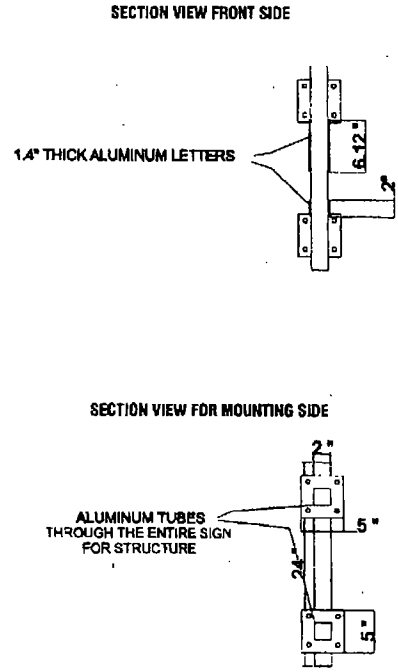
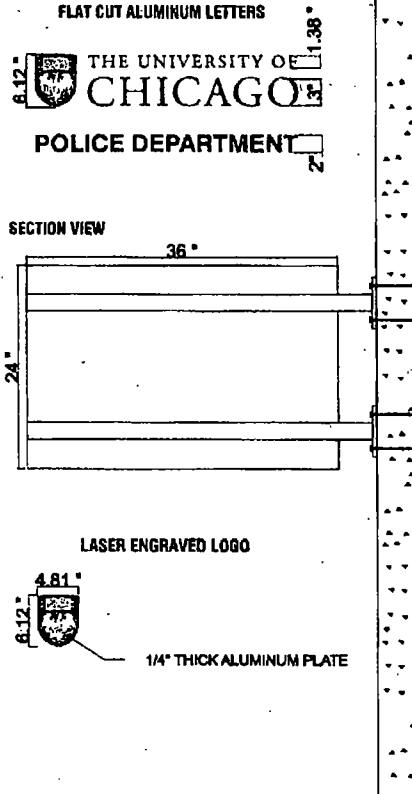
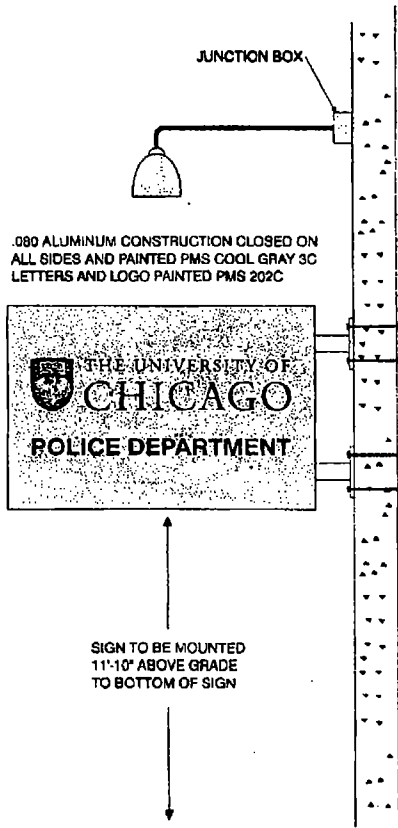

| | | |
|--|---|---|
| <p>These drawings are the exclusive property of Integrity Sign Company. Any use other than that intended is not allowed without the express written authorization of Integrity Sign Company. Ideas contained herein are considered intellectual property and are protected under law. © Integrity Sign Company. The prices, specifications and conditions as described are satisfactory and hereby accepted. Integrity Sign Company is authorized to do the work as specified.</p> | Directory Name: CAUsers\RIPPER\Desktop\INCOMING TEMP FOLDER | |
| | Customer: | Address: |
| | Current Date: 10/14/2013 | File Name: 20130918_Revised Police Station.fs |
| | Drawn By: JS | Salesperson: |
| | Approved By: | Date: |





Department of Business Affairs and Consumer Protection
Small Business Center - Public Way Use Unit
City Hall - 121 N. LaSalle Street, Room 800 • Chicago, IL 60602
(312)-74-GOBIZ (312-744-6249) • (312) 744-1944 (TTY)
<http://www.cityofchicago.org/bacp>

01/15/2014

Alderman **William D. Burns**
Ward # **04**
City of Chicago
City Hall, Room **300**
121 North LaSalle Street
Chicago, Illinois 60602

Re: An ordinance to use and maintain a portion of the public right-of-way for **one (1) sign(s)** for **Lake Park Associates**, adjacent to the premises known as **1411 E. 53rd St.**

Dear Alderman **William D. Burns**:

The applicant referenced above has requested the use of the public right-of-way for a **sign(s)**. An ordinance has been prepared by the Department of Business Affairs and Consumer Protection – Small Business Center - Public Way Use Unit for presentation to the City Council. Because this request was made for properties located in your ward, as approved by you as per the attached, I respectfully request that you introduce the attached ordinance at the next City Council meeting.

If you have any questions regarding this ordinance, please contact Anthony Bertuca at (312) 744-5506.

Department of Business Affairs and Consumer Protection