



# City of Chicago



O2017-6506

Office of the City Clerk

## Document Tracking Sheet

<b>Meeting Date:</b>	9/6/2017
<b>Sponsor(s):</b>	Dowell (3)
<b>Type:</b>	Ordinance
<b>Title:</b>	Grant(s) of privilege in public way for Red Apple Food & Liquor, Inc.
<b>Committee(s) Assignment:</b>	Committee on Transportation and Public Way

ORDINANCE  
RED APPLE FOOD & LIQUOR INC  
Acct. No. 4734 - 1  
Permit No. 1129164

*Be It Ordained by the City Council of the City of Chicago:*

SECTION 1. Permission and authority are hereby given and granted to RED APPLE FOOD & LIQUOR INC, upon the terms and subject to the conditions of this ordinance to maintain and use one (1) sign(s) projecting over the public right-of-way attached to its premises known as 317 E. 51st St..

Said sign structure(s) measures as follows; along E. 51st Street:  
One (1) at six (6) feet in length, four (4) feet in height and thirteen (13) feet above grade level.

The location of said privilege shall be as shown on prints kept on file with the Department of Business Affairs and Consumer Protection and the Office of the City Clerk.

Said privilege shall be constructed in accordance with plans and specifications approved by the Department of Transportation (Division of Project Development) and Zoning Department - Signs.

This grant of privilege in the public way shall be subject to the provisions of Section 10-28-015 and all other required provisions of the Municipal Code of Chicago.

The grantee shall pay to the City of Chicago as compensation for the privilege #1129164 herein granted the sum of one hundred (\$100.00) per annum in advance.

A 25% penalty will be added for payments received after due date.

The permit holder agrees to hold the City of Chicago harmless for any damage, relocation or replacement costs associated with damage, relocation or removal of private property caused by the City performing work in the public way.

Authority herein given and granted for a period of five (5) years from and after Date of Passage.

Alderman  \_\_\_\_\_

Pat Dowell 3<sup>rd</sup> Ward

# Existing Internally Illuminated Sign Box

**CROSS SECTION DETAIL**

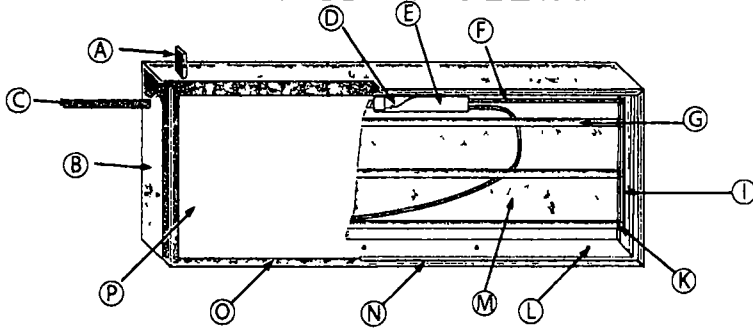

A	listed disconnect switch
B	Aluminum side
C	primary electrical source
D	H O Ballast
E	Ballast box
F	1/2" greenfield
G	Flourescent Lamp
H	
I	Wire way box
J	
K	Socket
L	Weep Holes
M	3/16 lexon second face
N	1 1/2" x 1 1/2" x 1/8" Steel Angle
O	2" x 2" Aluminum Retainers
P	3/16 White Lexon

All electrical to be UL listed

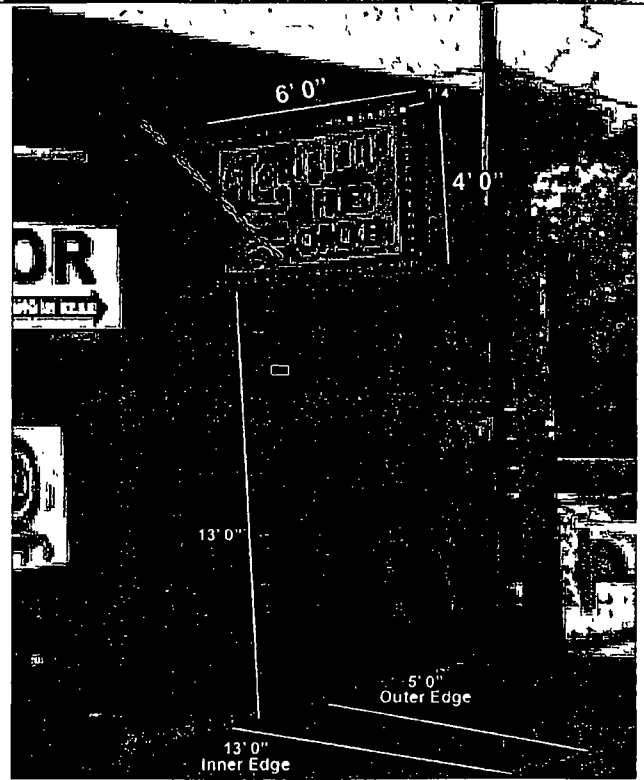

NOTE Photo for representational purposes only Signs are not to scale and may appear larger or smaller than shown

Sign Erector	Location	Description
<b>PRO IMAGE</b> 2006 W. Chicago, Ave. Chicago, IL 60622 Tel. 773 292 1111 Fax. 773 645 4169	<b>East Elevation</b> Address 317 E 51st ST Chicago, IL 60615	- EXISTING PROJECTING BOX ILLUMINATE SIGN - WALL MOUNTED - VINYL LETTERING BLACK & WHITE - 3/16 WHITE LEXON - INTERNALLY ILLUMINATE 4 FT FLOURESCENT LAMPS - READS LOUISIANA FAMOUS FRIED CHICKEN
	Date 7-10-2017	Client <b>RED APPLE FOOD &amp; LIQUOR</b>



**Department of Business Affairs and Consumer Protection**

Small Business Center - Public Way Use Unit

City Hall - 121 N LaSalle Street, Room 800 • Chicago, IL 60602

312-74-GOBIZ / 312-744-6249 • (312) 744-1944 (TTY)

<http://www.cityofchicago.org/bacp>

**09/06/2017**

**Alderman Pat Dowell**  
Ward # 03  
City of Chicago  
City Hall, Room 200  
121 North LaSalle Street  
Chicago, Illinois 60602

Re: An ordinance to use and maintain a portion of the public right-of-way for **one (1) sign(s)** for **RED APPLE FOOD & LIQUOR INC**, adjacent to the premises known as **317 E. 51st St.**.

Dear Alderman **Pat Dowell**:

The applicant referenced above has requested the use of the public right-of-way for a **sign(s)**. An ordinance has been prepared by the Department of Business Affairs and Consumer Protection – Small Business Center - Public Way Use Unit for presentation to the City Council. Because this request was made for properties located in your ward, as approved by you as per the attached, I respectfully request that you introduce the attached ordinance at the next City Council meeting.

If you have any questions regarding this ordinance, please contact Anthony Bertuca at (312) 744-5506.

**Department of Business Affairs and Consumer Protection**