



City of Chicago



O2013-5339

Office of the City Clerk Document Tracking Sheet

Meeting Date:	6/26/2013
Sponsor(s):	Reilly, Brendan (42)
Type:	Ordinance
Title:	Grant(s) of privilege in public way for Trader Joe's East
Committee(s) Assignment:	Committee on Transportation and Public Way

ORDINANCE
TRADER JOE'S EAST
Acct. No. 211718 - 3
Permit No. 1107188

Be It Ordained by the City Council of the City of Chicago:

SECTION 1. Permission and authority are hereby given and granted to TRADER JOE'S EAST, upon the terms and subject to the conditions of this ordinance to maintain and use three (3) sign(s) projecting over the public right-of-way attached to its premises known as 44 E. Ontario St..

Said sign structure(s) measures as follows; along N. Wabash & E. Ontario:

One (1) at five point five (5.5) feet in length, eight point five (8.5) feet in height and fifteen (15) feet above grade level.

Said sign structure(s) measures as follows; along E. Ontario St.:

One (1) at thirty-three point eight three (33.83) feet in length, three point five (3.5) feet in height and fifteen (15) feet above grade level.

Said sign structure(s) measures as follows; along N. Wabash Ave.:

One (1) at thirty-three point eight three (33.83) feet in length, three point five (3.5) feet in height and fifteen (15) feet above grade level.

The location of said privilege shall be as shown on prints kept on file with the Department of Business Affairs and Consumer Protection and the Office of the City Clerk.

Said privilege shall be constructed in accordance with plans and specifications approved by the Department of Transportation (Division of Project Development) and Zoning Department - Signs.

This grant of privilege in the public way shall be subject to the provisions of Section 10-28-015 and all other required provisions of the Municipal Code of Chicago.

The grantee shall pay to the City of Chicago as compensation for the privilege #1107188 herein granted the sum of nine hundred (\$900.00) per annum in advance.

A 25% penalty will be added for payments received after due date.

The permit holder agrees to hold the City of Chicago harmless for any damage, relocation or replacement costs associated with damage, relocation or removal of private property caused by the City performing work in the public way.

Authority herein given and granted for a period of five (5) years from and after 02/06/2013.

Alderman _____

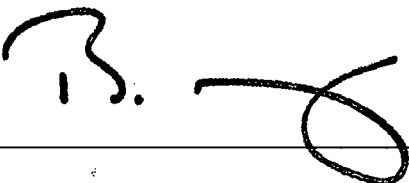

Brendan Reilly 42nd Ward

Contact: 1900 Ocean Avenue Ronkonkoma, NY 11779 P631 737 3140 F631 737 4865

Sign Type: CHANNEL LETTERS | Description: LED ILLUMINATED | Quantity: 2 | 1

STOREFRONT SIGN (EAST ELEVATION) | 128.80 SQ. FT. | SCALE: 1/4"=1'

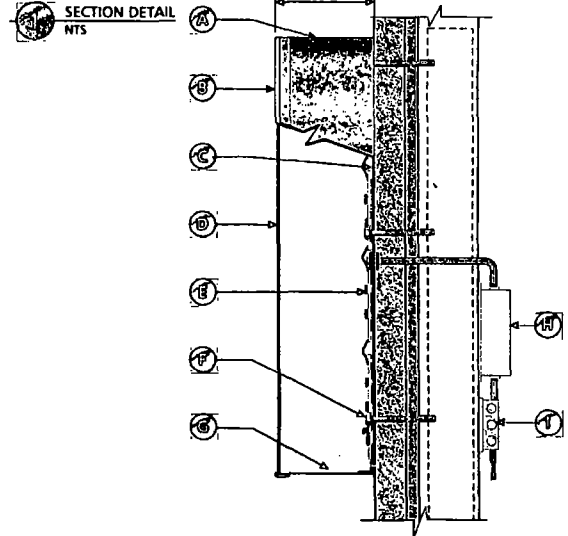
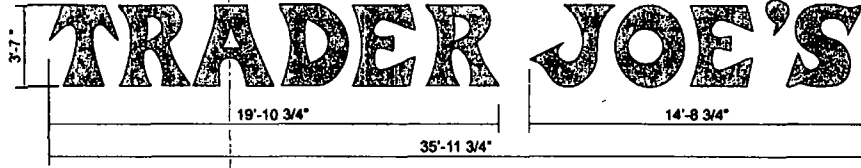

- A .040 Dark Bronze Anodized Aluminum Returns
- B 1" Continuous Jewlite Gold Trim Cap Fused To Acrylic Face.
- C .063 Aluminum Backs with White Inside.
- D .177 #2793 Red Acrylic Face
- E Red LED Lighting
- F Mounting Hardware Non-Corrosive Steel To Suit Wall Conditions
- G 1/4" Diameter Drain Hole (Min. 2 Per Letter)
- H LED Power Supply
- I 120v. Primary Power Junction Box

15 **broadwaynational**
SIGNS | LIGHTING | ELECTRICAL

Job Name: Trader Joe's
Address: 44 E. Ontario Street
Chicago, IL 60611

Date: 05.10.13
Job Number: 13778
Project Manager: ADS

Scale: See Drawing
Drawn By: PM
Revised: 05.10.13 #00.00

Approved Rejected
 Approved with Corrections Review and Resubmit
Signature: _____ Date: _____

This artwork is the property of Broadway National. Unauthorized use, publication or distribution is prohibited.