



City of Chicago



O2020-4911

Office of the City Clerk

Document Tracking Sheet

Meeting Date:	10/7/2020
Sponsor(s):	Hopkins (2)
Type:	Ordinance
Title:	Grant(s) of privilege in public way for Soulcycle - sign
Committee(s) Assignment:	Committee on Transportation and Public Way

ORDINANCE
SOULCYCLE
Acct. No. 394858 - 1
Permit No. 1146616

Be It Ordained by the City Council of the City of Chicago:

SECTION 1. Permission and authority are hereby given and granted to SOULCYCLE, upon the terms and subject to the conditions of this ordinance to maintain and use one (1) sign(s) projecting over the public right-of-way attached to its premises known as 1225 N. Wells St..

Said sign structure(s) measures as follows; along Wells:

One (1) at thirteen point one seven (13.17) feet in length, one point five (1.5) feet in height and fourteen (14) feet above grade level.

The location of said privilege shall be as shown on prints kept on file with the Department of Business Affairs and Consumer Protection and the Office of the City Clerk.

Said privilege shall be constructed in accordance with plans and specifications approved by the Department of Transportation (Division of Project Development) and Zoning Department - Signs.

This grant of privilege in the public way shall be subject to the provisions of Section 10-28-015 and all other required provisions of the Municipal Code of Chicago.

The grantee shall pay to the City of Chicago as compensation for the privilege #1146616 herein granted the sum of one hundred (\$100.00) per annum in advance.

A 25% penalty will be added for payments received after due date.

The permit holder agrees to hold the City of Chicago harmless for any damage, relocation or replacement costs associated with damage, relocation or removal of private property caused by the City performing work in the public way.

Authority herein given and granted for a period of five (5) years from and after 05/06/2020.

Alderman Brian Hopkins

Brian Hopkins 2nd Ward

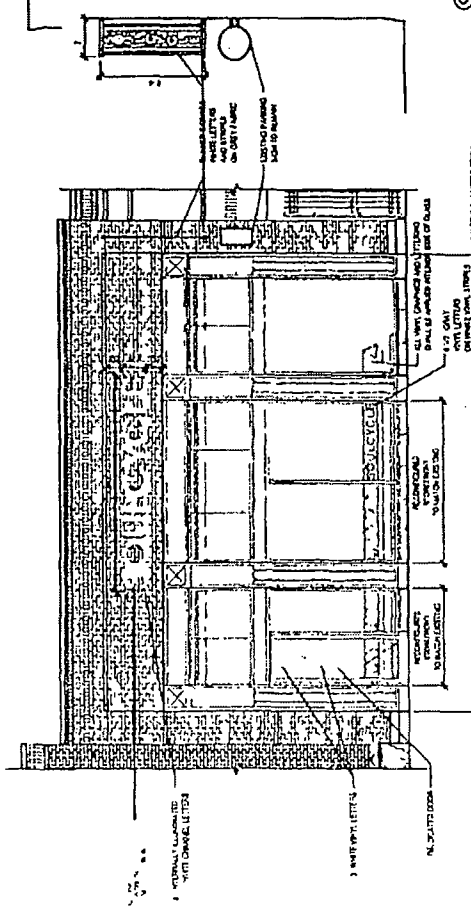
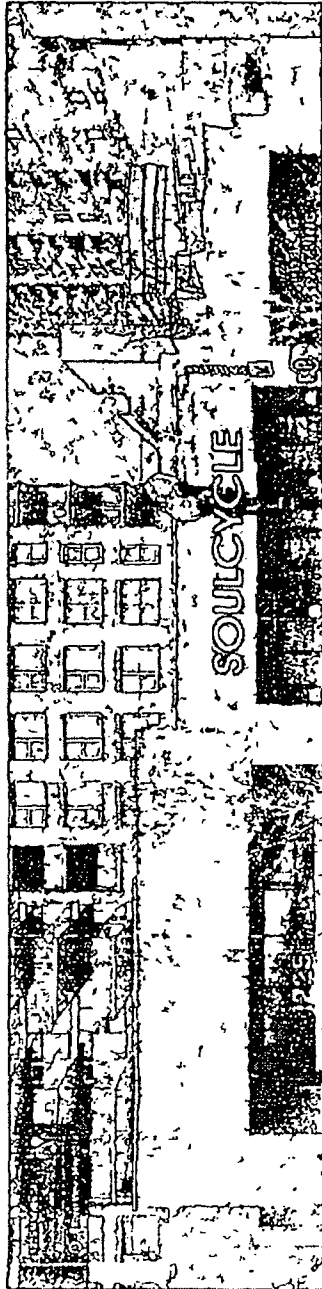

- A listed disconnect switch
- B fasteners as req'd
- C primary electrical source
- D metal box to house power supply
- E electronic power supply
- F 5" (0 063) alum returns
- G 1" trim cap
- H 3/16" thick plex face white #7328
- I PB3 or black plastic bushings
- J weep holes
- K GE power white LED Lights

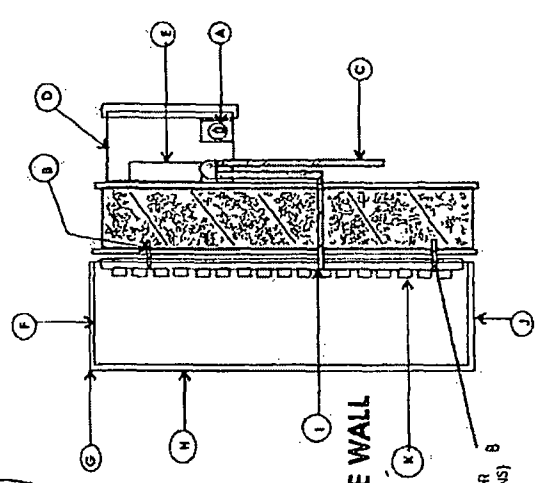

SIDE VIEW
CHANNEL LETTER FLUSH MOUNTED TO THE WALL

3/8" IDA SS MOUNTING ANCHOR
 (TYPE 18 D PER WALL CONDITIONS)
 THROUGH BOLT WHEN POSSIBLE

ACCEPTANCE / AUTHORIZATION CUSTOMER APPROVAL DATE		SALES REPRESENTATIVE DATE	
ELECTRICAL SERVICE AND CONNECTION RESPONSIBILITY OF THE CUSTOMER		DESIGN OF TURK ELECTRIC DESIGN • ENGINEERING • MAINTENANCE INSTALLATION • SERVICE • MAINTENANCE 775-736-9300 1300 N. CENTRAL AVENUE CHICAGO, IL 60641 PAPER/CAD/COPY/PRINTING COST	



Department of Business Affairs and Consumer Protection
Small Business Center - Public Way Use Unit
City Hall - 121 N LaSalle Street, Room 800 • Chicago, IL 60602
312-74-GOBIZ / 312-744-6249 • (312) 744-1944 (TTY)
<http://www.cityofchicago.org/bacp>

10/07/2020

Alderman Brian Hopkins
Ward # 02
City of Chicago
City Hall, Room 200
121 North LaSalle Street
Chicago, Illinois 60602

Re: An ordinance to use and maintain a portion of the public right-of-way for **one (1) sign(s)** for **SOULCYCLE**, adjacent to the premises known as **1225 N. Wells St.**

Dear Alderman **Brian Hopkins**:

The applicant referenced above has requested the use of the public right-of-way for a **sign(s)**. An ordinance has been prepared by the Department of Business Affairs and Consumer Protection – Small Business Center - Public Way Use Unit for presentation to the City Council. Because this request was made for properties located in your ward, as approved by you as per the attached, I respectfully request that you introduce the attached ordinance at the next City Council meeting.

If you have any questions regarding this ordinance, please contact Anthony Bertuca at (312) 744-5506.

Department of Business Affairs and Consumer Protection