



# City of Chicago



O2018-2913

Office of the City Clerk

## Document Tracking Sheet

|                                 |  |
|---------------------------------|--|
| <b>Meeting Date:</b>            | 3/28/2018                                  |
| <b>Sponsor(s):</b>              | Waguespack (32)                            |
| <b>Type:</b>                    | Ordinance                                  |
| <b>Title:</b>                   | Awning(s) for Smooth Your Bod              |
| <b>Committee(s) Assignment:</b> | Committee on Transportation and Public Way |

ORDINANCE  
Smooth Your Bod  
Acct. No. 354192 - 2  
Permit No. 1129549

*Be It Ordained by the City Council of the City of Chicago:*

SECTION 1. Permission and authority are hereby given and granted to Smooth Your Bod, upon the terms and subject to the conditions of this ordinance to construct, install, maintain and use two (2) Awning(s) projecting over the public right-of-way adjacent to its premises known as 1912 N. Damen Ave..

Said Awning(s) at Corner of Cortland and N Damen Ave measure(s):

One (1) at thirty-two (32) feet in length, and two (2) feet in width for a total of sixty-four (64) square feet.

Said Awning(s) at N Damen Ave measure(s):

One (1) at four (4) feet in length, and two (2) feet in width for a total of eight (8) square feet.

The location of said privilege shall be as shown on prints kept on file with the Department of Business Affairs and Consumer Protection and the Office of the City Clerk.

Said privilege shall be constructed in accordance with plans and specifications approved by the Zoning Department - Signs.

This grant of privilege in the public way shall be subject to the provisions of Section 10-28-015 and all other required provisions of the Municipal Code of Chicago.

The grantee shall pay to the City of Chicago as compensation for the privilege #1129549 herein granted the sum of one hundred seven (\$107.00) per annum in advance.

A 25% penalty will be added for payments received after due date.

The permit holder agrees to hold the City of Chicago harmless for any damage, relocation or replacement costs associated with damage, relocation or removal of private property caused by the City performing work in the public way.

Authority herein given and granted for a period of five (5) years from and after Date of Passage.

Alderman

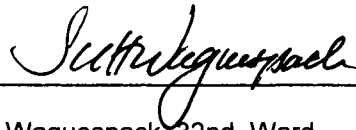

Scott Waguespack 32nd Ward

VERSION

1

Please carefully review and sign below if this layout meets your approval. Note that upon signing this graphics sheet you are approving this design for production. You will have approximately One (1) week from the date below to approve, before delaying production of your project.

This is an original drawing created by Chesterfield Awning Company Inc. It is being submitted for your personal use in connection with a project being planned for you by Chesterfield Awning Company Inc. It is not to be used, reproduced, copied or exhibited in any fashion. In the event any of the above occurs, Chesterfield Awning Company Inc. expects to be reimbursed \$250.00 in compensation for the time and effort entailed in creating this drawing.

**Chesterfield Awning Co**  
16999 Van Dam Rd  
South Holland, IL 60473  
(708) 596 4434  
www.chesterfieldawning.com

GENERAL AWNING SHAPE

TOP VIEW

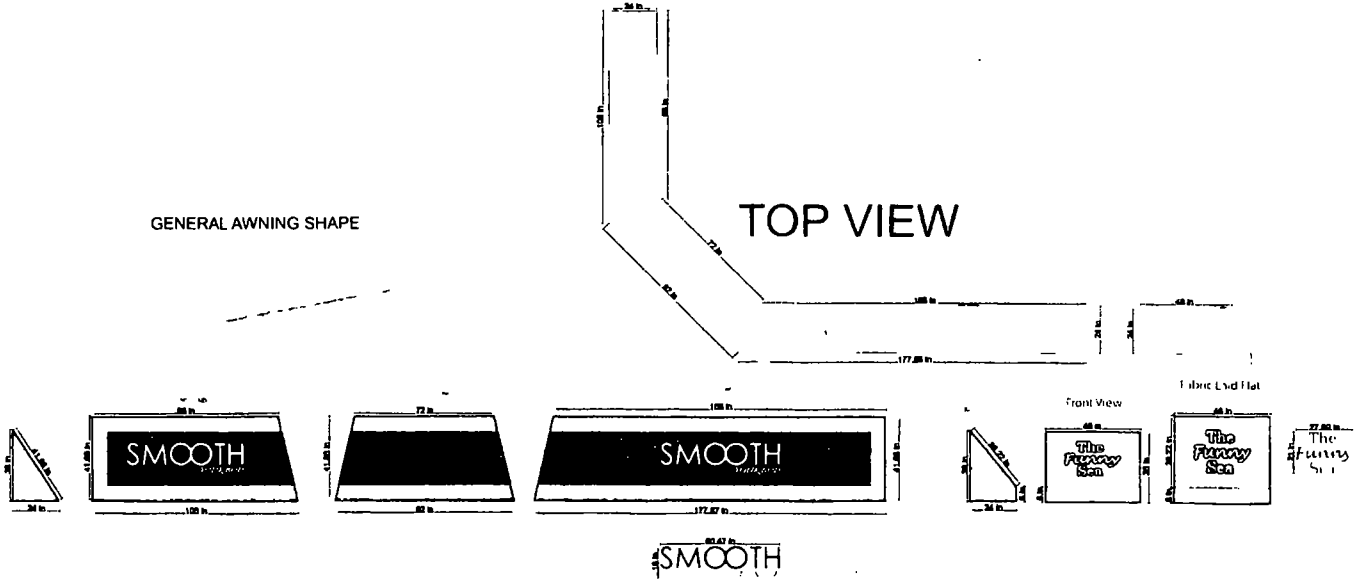

JOB NUMBER  
Job Name  
L.P.D.  
Font Style  
Size Style  
Color Method  
Scale Unit  
Date

Smooth Your Bod  
Sunbrella Aquamarine 4623 with sewn in  
Capn Navy Panel 4646  
White px 75 paint/ customer provided logo  
JL 08 18 2017

**PLEASE READ**  
Please carefully check for grammatical errors missing fonts placement sizing colors etc  
Please note this proof is not a true representation of color  
QUESTIONS PLEASE CONTACT: [sa@cheesterfieldawning.com](mailto:sa@cheesterfieldawning.com)  
PRINTED ON RECYCLED PAPER

Sizes are approximate, changes can/will be made after field measuring prior to installation.

**PLEASE CAREFULLY REVIEW THIS DRAWING IF YOU APPROVE IT VIA EMAIL OR BY SIGNING IT WITH INCORRECT INFORMATION IT WILL BE AT YOUR EXPENSE TO CORRECT**

Customer Approval: \_\_\_\_\_ Date: \_\_\_\_\_ Sales Approval: \_\_\_\_\_ Date: \_\_\_\_\_



**Department of Business Affairs and Consumer Protection**  
Small Business Center - Public Way Use Unit  
City Hall - 121 N. LaSalle Street, Room 800 • Chicago, IL 60602  
312-74-GOBIZ / 312-744-6249 • (312) 744-1944 (TTY)  
<http://www.cityofchicago.org/bacp>

**03/28/2018**

**Alderman Scott Waguespack**  
Ward # 32  
City of Chicago  
City Hall, Room 300  
121 North LaSalle Street  
Chicago, Illinois 60602

Re: An ordinance to use and maintain a portion of the public right-of-way for **two (2) awning(s)** for **Smooth Your Bod**, adjacent to the premises known as **1912 N. Damen Ave.**

Dear Alderman **Scott Waguespack**:

The applicant referenced above has requested the use of the public right-of-way for a **awning(s)**. An ordinance has been prepared by the Department of Business Affairs and Consumer Protection – Small Business Center - Public Way Use Unit for presentation to the City Council. Because this request was made for properties located in your ward, as approved by you as per the attached, I respectfully request that you introduce the attached ordinance at the next City Council meeting.

If you have any questions regarding this ordinance, please contact Anthony Bertuca at (312) 744-5506.

**Department of Business Affairs and Consumer Protection**

---