



City of Chicago



O2013-9358

Office of the City Clerk

Document Tracking Sheet

Meeting Date:	11/26/2013
Sponsor(s):	Cappleman (46)
Type:	Ordinance
Title:	Grant(s) of privilege in public way for Central Lakeview Merchants Assn. - 3957 N. Sheridan Rd
Committee(s) Assignment:	Committee on Transportation and Public Way

ORDINANCE
CENTRAL LAKEVIEW MERCHANTS ASSOCIATION
Acct. No. 314738 - 117
Permit No. 1109135

Be It Ordained by the City Council of the City of Chicago:

SECTION 1. Permission and authority are hereby given and granted to CENTRAL LAKEVIEW MERCHANTS ASSOCIATION, upon the terms and subject to the conditions of this ordinance to construct, install, maintain and use two (2) Bicycle Rack(s) on the public right-of-way adjacent to its premises known as 3957 N. Sheridan Rd..

Said Bicycle Rack(s) at N. Sheridan Road measure(s):

Two (2) at five point five (5.5) feet in length, and point one seven (.17) feet in width for a total of one point eight seven (1.87) square feet.

The location of said privilege shall be as shown on prints kept on file with the Department of Business Affairs and Consumer Protection and the Office of the City Clerk.

Said privilege shall be constructed in accordance with plans and specifications approved by the Department of Planning and Development and Department of Transportation (Division of Project Development).

This grant of privilege in the public way shall be subject to the provisions of Section 10-28-015 and all other required provisions of the Municipal Code of Chicago.

The grantee shall pay to the City of Chicago as compensation for the privilege #1109135 herein granted the sum of zero (\$0.00) per annum in advance.

A 25% penalty will be added for payments received after due date.

The permit holder agrees to hold the City of Chicago harmless for any damage, relocation or replacement costs associated with damage, relocation or removal of private property caused by the City performing work in the public way.

Authority herein given and granted for a period of five (5) years from and after Date of Passage.

Alderman _____

James Cappleman 46th Ward

BIKE BIKE RACK

Specifications and Space Use

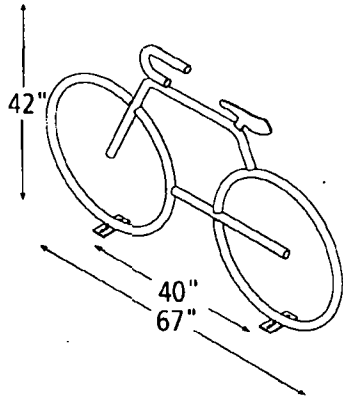

Product Dero Bike Bike Rack
As manufactured by Dero Bike Racks

Capacity 2-4 Bikes

Materials 1.5" OD 11 Gauge Tube. All open ends are capped to prevent moisture from entering. All welds are MIG welds around entire circumference of joined pieces.

Finishes An after fabrication hot dipped galvanized finish is our standard option. 250 TGIC powder coat colors, thermoplastic coating, and stainless steel finishes are also available as alternate options.

Our powder coat finish assures a high level of adhesion and durability by following these steps:
 1. Sandblast
 2. Epoxy primer electrostatically applied
 3. Final thick TGIC polyester powder coat

Stainless Steel: 304 grade stainless steel material finished in either a high polished shine or a satin finish.

Installation Methods Each rack has two 2.5" x 6" mounting brackets double gusset welded to the "wheels". The brackets are 40" apart. Each bracket is anchored to the ground with two anchors. Anchors are included with each rack

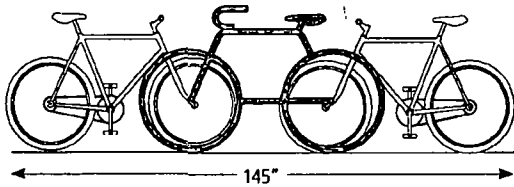

Space Use and Setbacks **Wall Setbacks:**
 For racks set parallel to a wall:
 Minimum: 24"
 Recommended: 36"

For racks set perpendicular to a wall:
 Minimum: 64" (to allow maximum capacity of 4 bikes)

Distance Between Racks:
 Minimum: 24"
 Recommended: 36"

Street Setbacks:
 Minimum: 36"

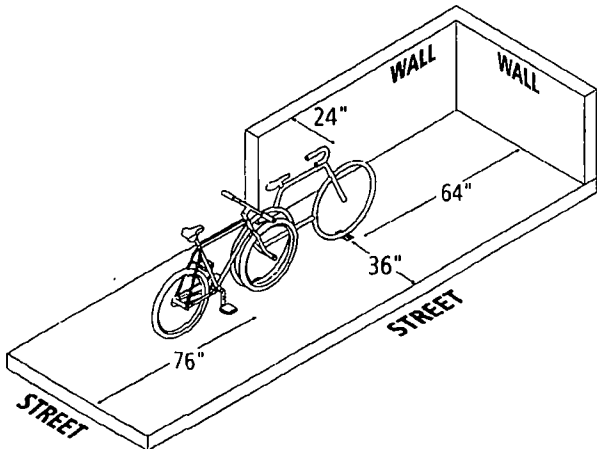



11/26/2013

Alderman **James Cappleman**
Ward # **46**
City of Chicago
City Hall, Room **300**
121 North LaSalle Street
Chicago, Illinois 60602

Re: An ordinance to use and maintain a portion of the public right-of-way for **two (2) bicycle rack(s)** for **CENTRAL LAKEVIEW MERCHANTS ASSOCIATION**, adjacent to the premises known as **3957 N. Sheridan Rd..**

Dear Alderman **James Cappleman**:

The applicant referenced above has requested the use of the public right-of-way for a **bicycle rack(s)**. An ordinance has been prepared by the Department of Business Affairs and Consumer Protection – Business Assistance Center - Public Way Use Unit for presentation to the City Council. Because this request was made for properties located in your ward, as approved by you as per the attached, I respectfully request that you introduce the attached ordinance at the next City Council meeting.

If you have any questions regarding this ordinance, please contact Anthony Bertuca at (312) 744-5506.

Department of Business Affairs and Consumer Protection