



Office of the Chicago City
Clerk



Or2011-848

Office of the City Clerk

City Council Document Tracking Sheet

Meeting Date:	9/8/2011
Sponsor(s):	Cullerton, Timothy M. (38)
Type:	Order
Title:	Issuance of permit(s) for sign(s)/signboard(s) at 3925 N Cicero Ave
Committee(s) Assignment:	Committee on Zoning, Landmarks and Building Standards

Committee on Buildings

(signs)

ORDERED, That the Commissioner of Buildings is hereby directed to issue a sign permit to: (Contractor's name and address)

Sure Light Sign Company

1225 Bowes Road

Elgin IL 60123

for the erection of a sign/signboard over 24 feet in height and/or over 100 square feet (in area of one face) at: (Business NAME & ADDRESS)

CW Price

3925 N. Cicero Ave.

Chicago,

Dimensions: length 31' 11" height 8'

height above grade/roof to top of sign 22'

TOTAL SQUARE FOOT AREA 255

Such sign(s) shall comply with all applicable provisions of TITLE 17 of the Chicago Zoning Ordinance and all other applicable provisions of the Municipal Code of the City of Chicago governing the construction and maintenance of outdoor signs, signboards and structures.



Alderman, Ward 38
Timothy Cullerton

60" TALL LETTERS

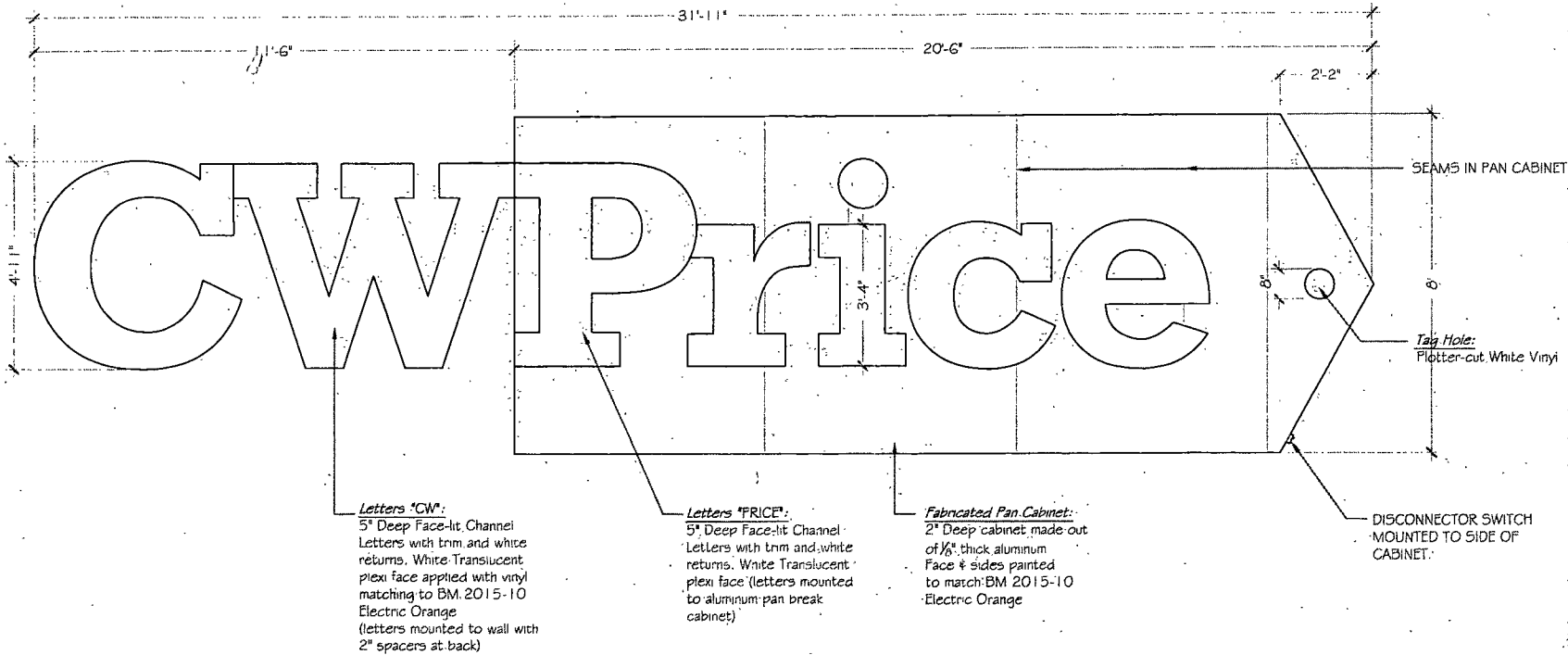

1 SIGN TYPE - C (60" tall)
Face-Lit Channel Letters & Cabinet

OPTION 1:
WHEN CABINET IS ORANGE "PRICE" LETTERS WILL BE WHITE.
LETTERS "CW" WILL BE ORANGE

OPTION 2:
WHEN CABINET IS WHITE "PRICE" LETTERS WILL BE ORANGE
LETTERS "CW" WILL BE WHITE



Client	CW PRICE
Project Location	New York
Project No.	
Project Manager	
Drawing Title	Elevation
Scale/Person	World K. / Amir K.
Designer	Abdul
Revisions	

Remark	
Drawing No	Date
	5.17.2011

nyc office
247 west 35th street
new york, ny 10001
phone 212.629.3650
fax 212.629.4954

manufacturing facility
3 oval drive
Islandia, ny 11749
phone 631.342.0303
fax 631.342.0424

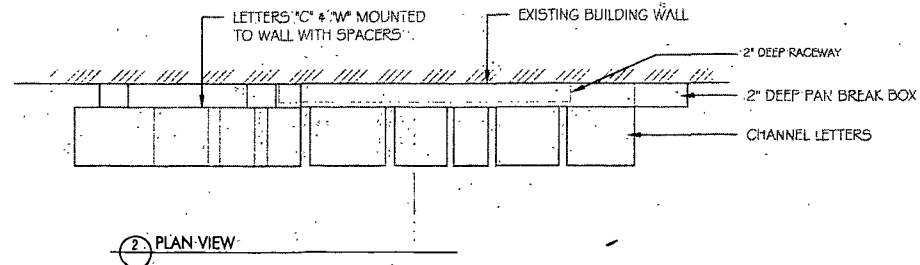
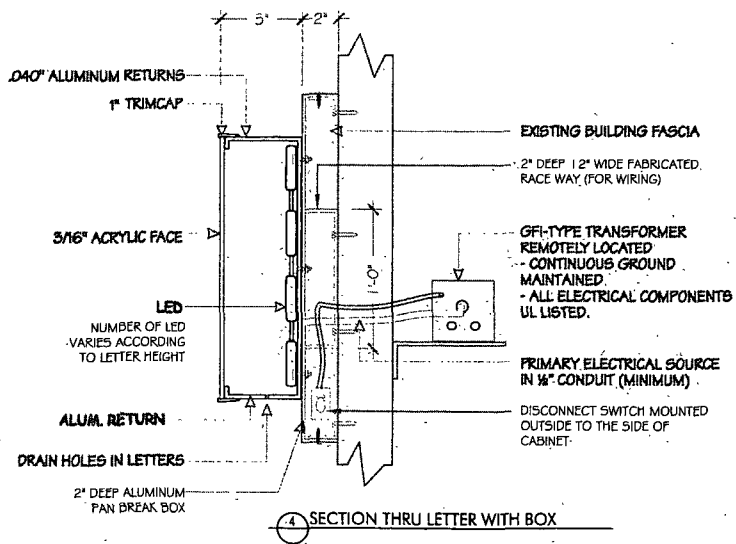
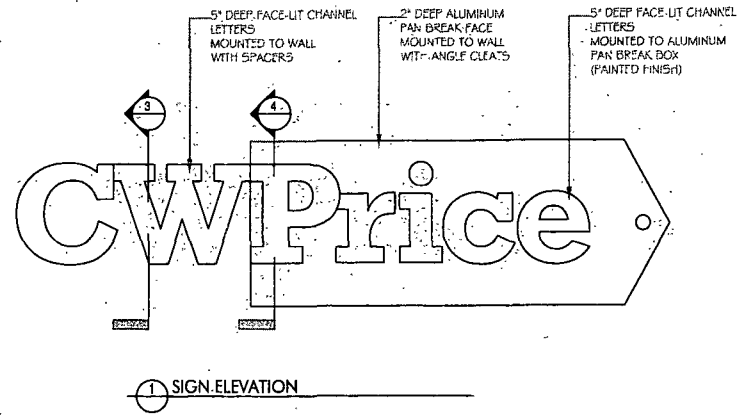
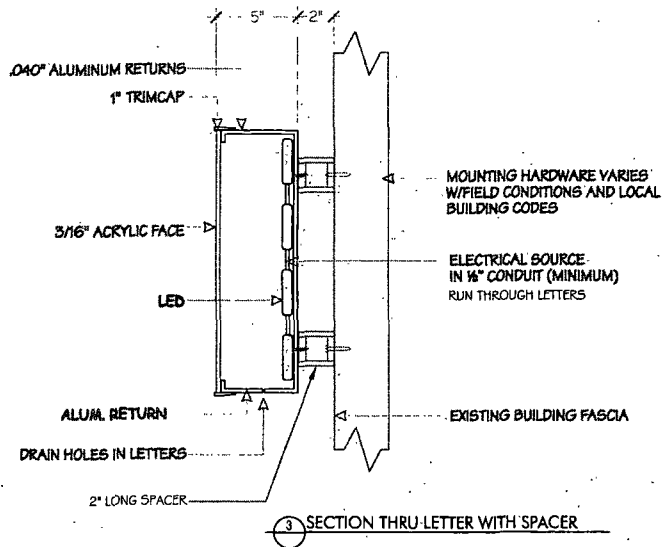

MOUNTING HARDWARE VARIES W/FIELD CONDITIONS AND LOCAL BUILDING CODES



Client
 CW PRICE
 Project Location
 New York
 Project No.
 Project Manager
 Drawing Title
 Elevation
 Salesperson
 Wahid R. / Amir K
 Designer
 Aadi J
 Elevations
 Remark

Drawing No. | Date
 | 5.17.2011

nyc office.
 247 west 35th street
 new york, ny 10001
 phone 212.629.3650
 fax 212.629.4954

manufacturing facility
 3 oval drive
 istadla, ny 11749
 phone 631.342.0303
 fax 631.342.0424

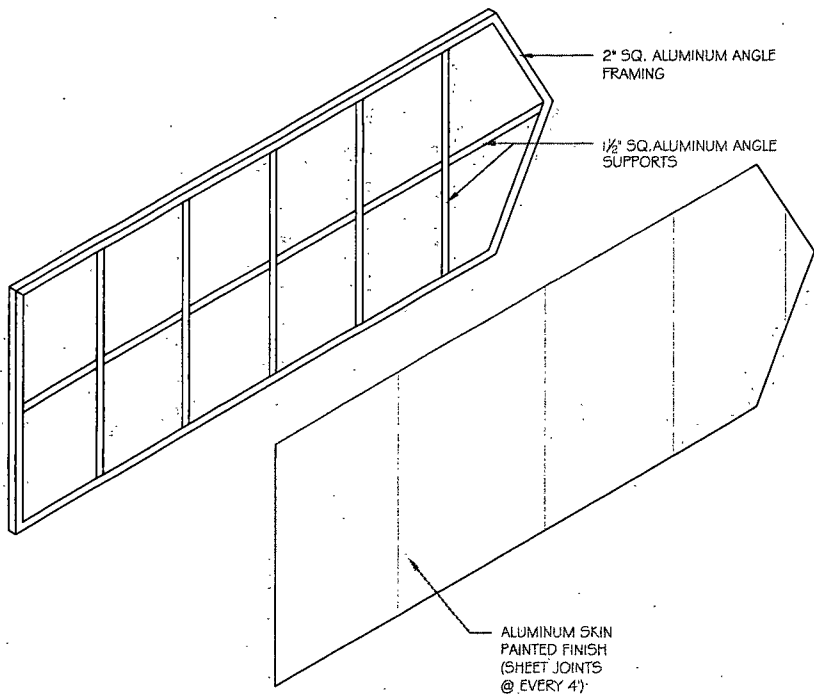

1 ISOMETRIC VIEW
FRAMING & SKIN - CABINET

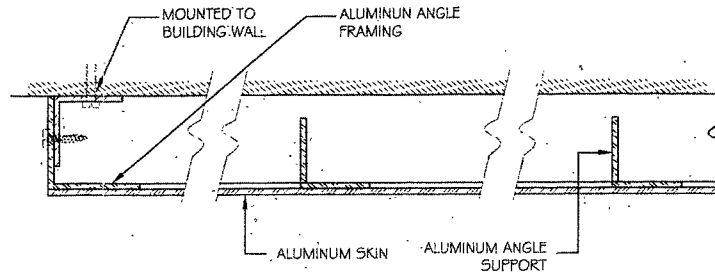

2 PART SECTION THRU CABINET

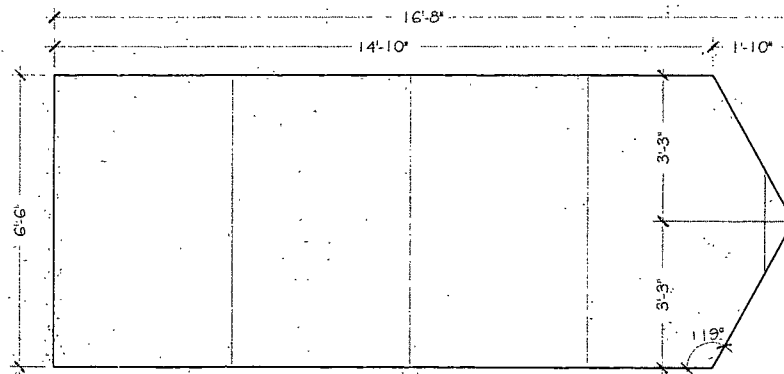
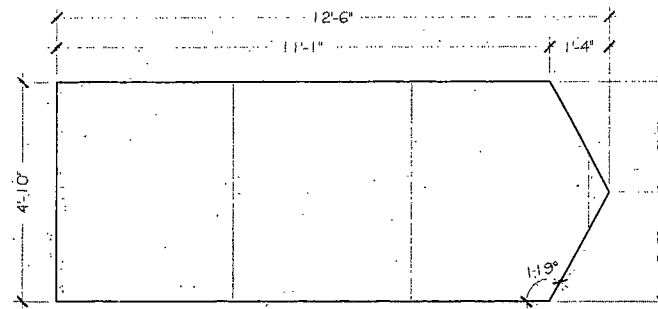

1 ELEVATION - CABINET
SIGN TYPE - 'A' & TYPE - 'B'



Client: _____

CW PRICE _____

Project Location: _____
New York

Project No. _____

Project Manager: _____

Drawing Title: _____
Elevation

Salesperson: _____
Wahid R. / Amir K.

Designer: _____
Abdul

Revisions _____

Remark _____

Drawing No. _____ Date: 5.17.2011

nyc-office
247 west 35th street
new york, ny 10001
phone 212.629.3650
fax 212.629.4954

manufacturing facility
3-oval drive
islandia, ny-11749
phone 631.342.0303
fax 631.342.0424