



City of Chicago



O2015-6645

Office of the City Clerk

Document Tracking Sheet

Meeting Date:	9/24/2015
Sponsor(s):	Hopkins (2)
Type:	Ordinance
Title:	Awning(s) for Cocoa & Co.
Committee(s) Assignment:	Committee on Transportation and Public Way

ORDINANCE
COCOA & CO.
Acct. No. 395833 - 1
Permit No. 1118559

Be It Ordained by the City Council of the City of Chicago:

SECTION 1. Permission and authority are hereby given and granted to COCOA & CO., upon the terms and subject to the conditions of this ordinance to construct, install, maintain and use one (1) Awning(s) projecting over the public right-of-way adjacent to its premises known as 1651 N. Wells St..

Said Awning(s) at N. Wells measure(s):

One (1) at sixteen point seven five (16.75) feet in length, and four point six seven (4.67) feet in width for a total of seventy-eight point two two (78.22) square feet.

The location of said privilege shall be as shown on prints kept on file with the Department of Business Affairs and Consumer Protection and the Office of the City Clerk.

Said privilege shall be constructed in accordance with plans and specifications approved by the Zoning Department - Signs.

This grant of privilege in the public way shall be subject to the provisions of Section 10-28-015 and all other required provisions of the Municipal Code of Chicago.

The grantee shall pay to the City of Chicago as compensation for the privilege #1118559 herein granted the sum of fifty (\$50.00) per annum in advance.

A 25% penalty will be added for payments received after due date.

The permit holder agrees to hold the City of Chicago harmless for any damage, relocation or replacement costs associated with damage, relocation or removal of private property caused by the City performing work in the public way.

Authority herein given and granted for a period of five (5) years from and after Date of Passage.

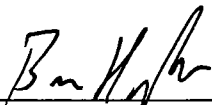
Alderman  _____

Brian Hopkins 2nd Ward

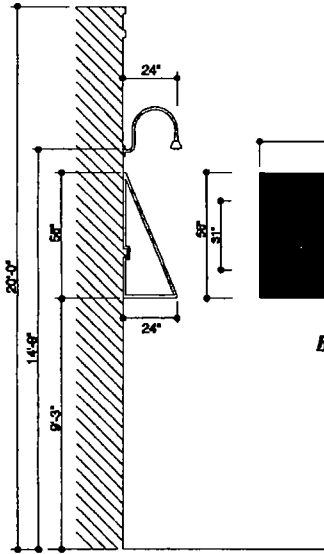

SIDE VIEW 1/4" = 1'-0"

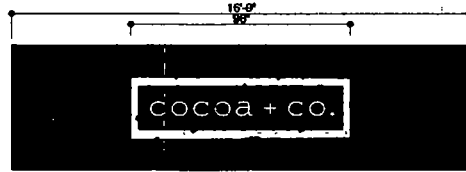

REFACE EXISTING AWNING DISPLAY 1/4" = 1'-0"

BLACK SUNBRELLA COVERING W/ #121 SILVER THERMAL APPLIED GRAPHICS.

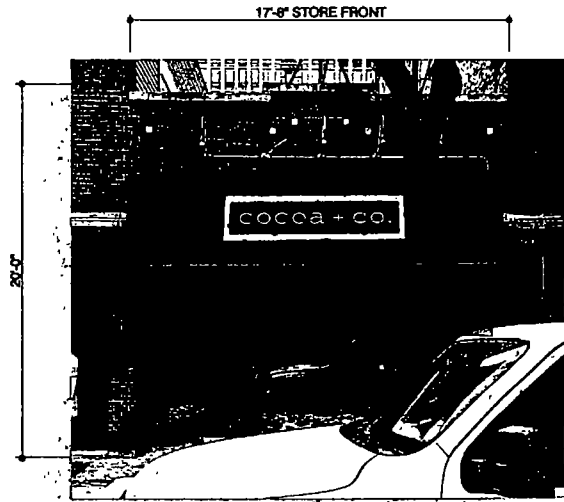

17'-8" STORE FRONT

5'-0"

OLYMPIC SIGNS

account representative / client
L. GOTTFRIED

COCOA + CO.

1061 N WELLS CHICAGO, IL

drawn by
JOHN W

job #: 15-6960
2-25-15
rev # 4-9-15

1800 W. 18TH STREET, CHICAGO, IL 60608 TEL: 630.424.6100 FAX: 630.424.6120 WWW.OLYMPICSIGNS.COM

THIS IS AN ORIGINAL UNAPPROVED DRAWING. ANY REPRODUCTION OR CONSTRUCTION OF THIS PROJECT WITHOUT APPROVAL FROM THE ORIGINAL DESIGNER IS STRICTLY PROHIBITED. THIS DRAWING IS NOT TO BE COPIED, REPRODUCED, OR TRANSMITTED IN ANY FORM OR BY ANY MEANS, ELECTRONIC OR MECHANICAL, INCLUDING PHOTOCOPYING, RECORDING, OR BY ANY INFORMATION STORAGE AND RETRIEVAL SYSTEM. ANY REPRODUCTION OR CONSTRUCTION OF THIS PROJECT WITHOUT APPROVAL FROM THE ORIGINAL DESIGNER IS STRICTLY PROHIBITED. THIS DRAWING IS NOT TO BE COPIED, REPRODUCED, OR TRANSMITTED IN ANY FORM OR BY ANY MEANS, ELECTRONIC OR MECHANICAL, INCLUDING PHOTOCOPYING, RECORDING, OR BY ANY INFORMATION STORAGE AND RETRIEVAL SYSTEM. ANY REPRODUCTION OR CONSTRUCTION OF THIS PROJECT WITHOUT APPROVAL FROM THE ORIGINAL DESIGNER IS STRICTLY PROHIBITED. THIS DRAWING IS NOT TO BE COPIED, REPRODUCED, OR TRANSMITTED IN ANY FORM OR BY ANY MEANS, ELECTRONIC OR MECHANICAL, INCLUDING PHOTOCOPYING, RECORDING, OR BY ANY INFORMATION STORAGE AND RETRIEVAL SYSTEM.

Customer's Signature: _____ Date: _____

Comments:

EXISTING

PROPOSED



09/24/2015

Alderman **Brian Hopkins**
Ward # **02**
City of Chicago
City Hall, Room **200**
121 North LaSalle Street
Chicago, Illinois 60602

Re: An ordinance to use and maintain a portion of the public right-of-way for **one (1) awning(s)** for **COCOA & CO.**, adjacent to the premises known as **1651 N. Wells St.**

Dear Alderman **Brian Hopkins**:

The applicant referenced above has requested the use of the public right-of-way for a **awning(s)**. An ordinance has been prepared by the Department of Business Affairs and Consumer Protection – Small Business Center - Public Way Use Unit for presentation to the City Council. Because this request was made for properties located in your ward, as approved by you as per the attached, I respectfully request that you introduce the attached ordinance at the next City Council meeting.

If you have any questions regarding this ordinance, please contact Anthony Bertuca at (312) 744-5506.

Department of Business Affairs and Consumer Protection