



# City of Chicago



O2013-7792

Office of the City Clerk

## Document Tracking Sheet

<b>Meeting Date:</b>	10/16/2013
<b>Sponsor(s):</b>	Harris (8)
<b>Type:</b>	Ordinance
<b>Title:</b>	Awning(s) for Sun Beauty Supply, Inc.
<b>Committee(s) Assignment:</b>	Committee on Transportation and Public Way

ORDINANCE  
SUN BEAUTY SUPPLY INC  
Acct. No. 207652 - 1  
Permit No. 1104377

*Be It Ordained by the City Council of the City of Chicago:*

SECTION 1. Permission and authority are hereby given and granted to SUN BEAUTY SUPPLY INC, upon the terms and subject to the conditions of this ordinance to construct, install, maintain and use two (2) Awning(s) projecting over the public right-of-way adjacent to its premises known as 1634 E. 87th St..

Said Awning(s) at E 87TH ST measure(s):

Two (2) at thirteen (13) feet in length, and one (1) foot in width for a total of twenty-six (26) square feet.

The location of said privilege shall be as shown on prints kept on file with the Department of Business Affairs and Consumer Protection and the Office of the City Clerk.

Said privilege shall be constructed in accordance with plans and specifications approved by the Zoning Department - Signs.

This grant of privilege in the public way shall be subject to the provisions of Section 10-28-015 and all other required provisions of the Municipal Code of Chicago.

The grantee shall pay to the City of Chicago as compensation for the privilege #1104377 herein granted the sum of one hundred (\$100.00) per annum in advance.

A 25% penalty will be added for payments received after due date.

The permit holder agrees to hold the City of Chicago harmless for any damage, relocation or replacement costs associated with damage, relocation or removal of private property caused by the City performing work in the public way.

Authority herein given and granted for a period of five (5) years from and after Date of Passage.

Alderman 

Michelle A. Harris 8th Ward

# tfasigns

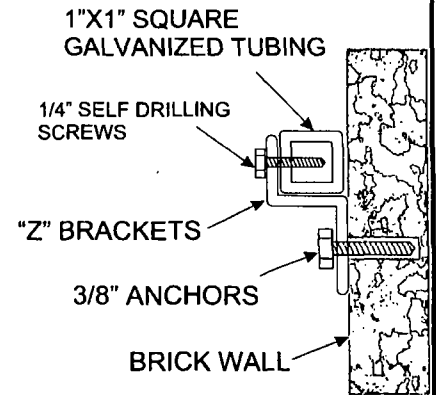
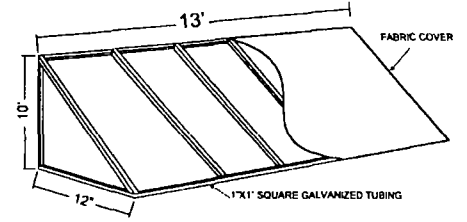
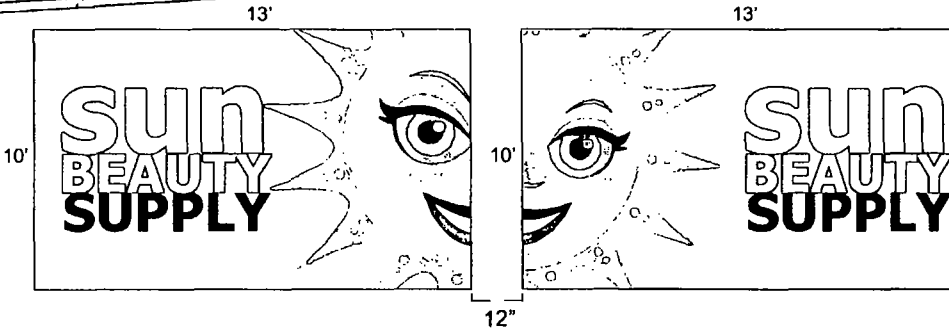

# tfasigns

**Store Name:**  
SUN BEAUTY SUPPLY  
**Location:**  
1634 E. 87TH ST.  
CHICAGO, IL 60617

**Client Name:**  
**Phone:**  
**Landlord:**  
**Address:**

Client Approval (signature) \_\_\_\_\_ Date \_\_\_\_\_

Landlord Approval (signature) \_\_\_\_\_ Date \_\_\_\_\_

**Sales Rep:**  
SEAN PARK  
**Designer:**  
SEAN PARK





**10/16/2013**

**Alderman Michelle A. Harris**  
Ward # **08**  
City of Chicago  
City Hall, Room **300**  
121 North LaSalle Street  
Chicago, Illinois 60602

Re: An ordinance to use and maintain a portion of the public right-of-way for **two (2) awning(s)** for **SUN BEAUTY SUPPLY INC**, adjacent to the premises known as **1634 E. 87th St.**.

Dear Alderman **Michelle A. Harris**:

The applicant referenced above has requested the use of the public right-of-way for a **awning(s)**. An ordinance has been prepared by the Department of Business Affairs and Consumer Protection – Business Assistance Center - Public Way Use Unit for presentation to the City Council. Because this request was made for properties located in your ward, as approved by you as per the attached, I respectfully request that you introduce the attached ordinance at the next City Council meeting.

If you have any questions regarding this ordinance, please contact Anthony Bertuca at (312) 744-5506.

**Department of Business Affairs and Consumer Protection**