



# City of Chicago



O2021-3761

Office of the City Clerk

## Document Tracking Sheet

<b>Meeting Date:</b>	9/14/2021
<b>Sponsor(s):</b>	Vasquez, Jr. (40)
<b>Type:</b>	Ordinance
<b>Title:</b>	Awning(s) for Sabor A Cafe Restaurant
<b>Committee(s) Assignment:</b>	Committee on Transportation and Public Way

ORDINANCE

SABOR A CAFE RESTAURANT

Acct. No.: 219937 - 1

Permit No: BACP1148313

*Be It Ordained by the City Council of the City of Chicago:*

SECTION 1. Permission and authority are hereby given and granted to SABOR A CAFE RESTAURANT upon the terms and subject to the conditions of this ordinance to maintain and use, as now constructed, two (2) Awning with Lettering or Graphics(s) projecting over the public right-of-way adjacent to its premises known as 2435 W PETERSON AVE.

Said Awning with Lettering or Graphics(s) at W. Peterson Avenue measure(s):

One (1) at thirty-three (33) feet in length and Zero (0) feet in width for a total of thirty-three (33) square feet.

Said Awning with Lettering or Graphics(s) at measure(s):

One (1) at twelve (12) feet in length and Zero (0) feet in width for a total of twelve (12) square feet.

The location of said privilege shall be as shown on prints kept on file with the Department of Business Affairs and Consumer Protection and the Office of the City Clerk.

Said privilege shall be constructed in accordance with plans and specifications approved by the Zoning Department - Signs.

This grant of privilege in the public way shall be subject to the provisions of Section 10-28-015 and all other required provisions of the Municipal Code of Chicago.

The grantee shall pay to the City of Chicago as compensation for the privilege #BACP1148313 herein granted the sum of one hundred eight (\$108.00) per annum in advance.

A 25% penalty will be added for payments received after due date.

The permit holder agrees to hold the City of Chicago harmless for any damage, relocation or replacement costs associated with damage, relocation or removal of private property caused by the City performing work in the public way.

Authority herein given and granted for a period of five (5) years from and after 12/17/2018.

Alderman:



---

Andre Vasquez 40th Ward

# GENERAL SPECIFICATIONS

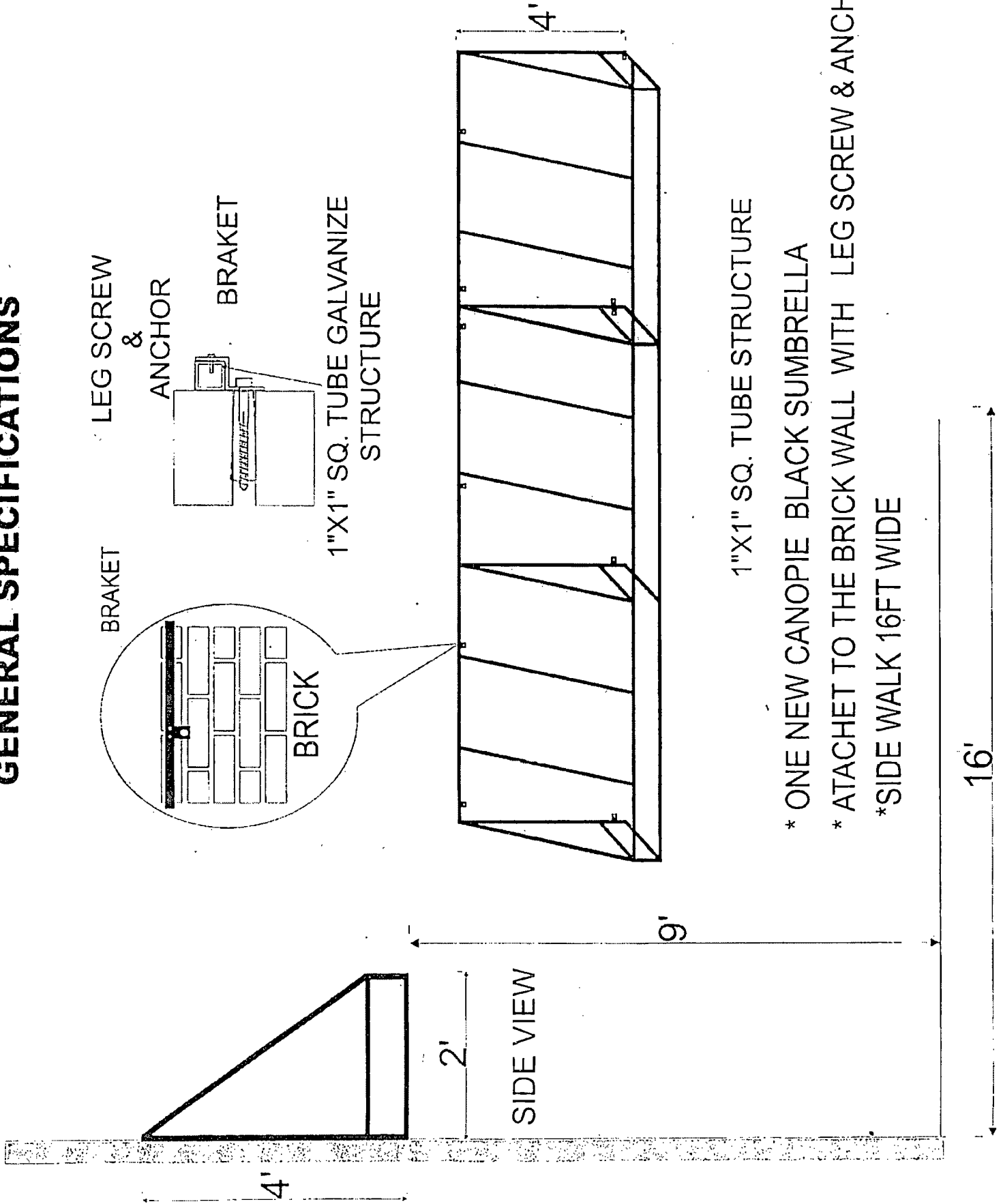

- \* ONE NEW CANOPIE BLACK SUMBRELLA
- \* ATACHET TO THE BRICK WALL WITH LEG SCREW & ANCHOR
- \* SIDE WALK 16FT WIDE



**Department of Business Affairs and Consumer Protection**  
Small Business Center - Public Way Use Unit  
City Hall - 121 N LaSalle Street, Room 800, Chicago, IL 60602  
312-74-GOBIZ / 312-744-6249 • (312) 744-1944 (TTY)  
<http://www.cityofchicago.org/bacp>

09/14/2021

Alderman Andre Vasquez  
Ward # 40  
City of Chicago  
City Hall, Room 800  
121 N. LaSalle Street  
Chicago, IL 60602

Re: An ordinance to use and maintain a portion of the public right-of-way for **2 Awning with Lettering or Graphics(s)** for **SABOR A CAFE RESTAURANT**, adjacent to the premises known as **2435 W PETERSON AVE.**

Dear Alderman **Andre Vasquez**:

The applicant referenced above has requested the use of the public right-of-way for **Awning with Lettering or Graphics(s)**. An ordinance has been prepared by the Department of Business Affairs and Consumer Protection - Small Business Center - Public Way Use Unit for presentation to the City Council. Because this request was made for properties located in your ward, as approved by you as per the attached, I respectfully request that you introduce the attached ordinance at the next City Council meeting.

If you have any questions regarding this ordinance, please contact Anthony Bertuca at (312) 744-5506.

**Department of Business Affairs and Consumer Protection**