



City of Chicago



O2014-9986

Office of the City Clerk

Document Tracking Sheet

Meeting Date:	12/10/2014
Sponsor(s):	Osterman (48)
Type:	Ordinance
Title:	Grant(s) of privilege in public way for Chicago Housing Authority
Committee(s) Assignment:	Committee on Transportation and Public Way

ORDINANCE
CHICAGO HOUSING AUTHORITY
Acct. No. 57934 - 8
Permit No. 1116007

Be It Ordained by the City Council of the City of Chicago:

SECTION 1. Permission and authority are hereby given and granted to CHICAGO HOUSING AUTHORITY, upon the terms and subject to the conditions of this ordinance to maintain and use, as now constructed, two (2) Bicycle Rack(s) on the public right-of-way adjacent to its premises known as 5040 N. Kenmore Ave..

Said Bicycle Rack(s) at N. Kenmore Avenue measure(s):

Two (2) at two point five (2.5) feet in length, and point one six (.16) feet in width for a total of point eight (.8) square feet.

The location of said privilege shall be as shown on prints kept on file with the Department of Business Affairs and Consumer Protection and the Office of the City Clerk.

Said privilege shall be constructed in accordance with plans and specifications approved by the Department of Planning and Development and Department of Transportation (Division of Project Development).

This grant of privilege in the public way shall be subject to the provisions of Section 10-28-015 and all other required provisions of the Municipal Code of Chicago.

The grantee shall pay to the City of Chicago as compensation for the privilege #1116007 herein granted the sum of zero (\$.00) per annum in advance.

A 25% penalty will be added for payments received after due date.

The permit holder agrees to hold the City of Chicago harmless for any damage, relocation or replacement costs associated with damage, relocation or removal of private property caused by the City performing work in the public way.

Authority herein given and granted for a period of five (5) years from and after 10/07/2014.

Alderman _____



Harry Osterman 48th Ward



FREMONT™ BIKE RACK



PRODUCT DATA

CONFIGURATION OPTIONS

The Fremont Bike Rack was designed to allow for a multitude of configuration options to meet your individual needs. Please note that for optimal performance, Forms+Surfaces recommends a 30" center to center placement (see diagrams below for more details)

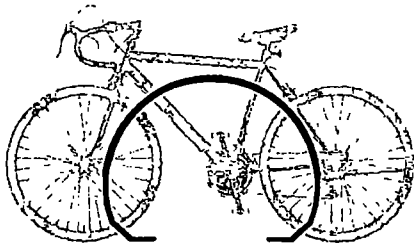

SIDE DETAIL

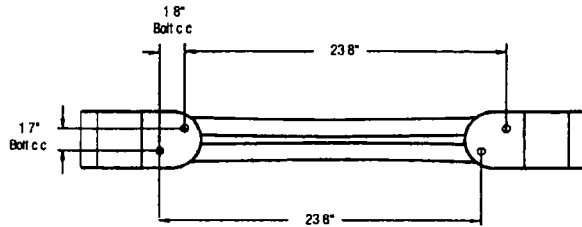

MOUNTING / HARDWARE DETAIL

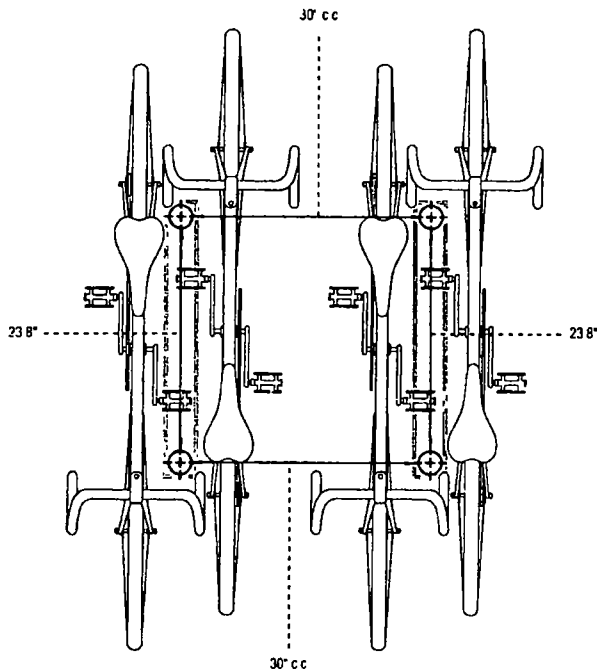

CONFIGURATION OPTION A

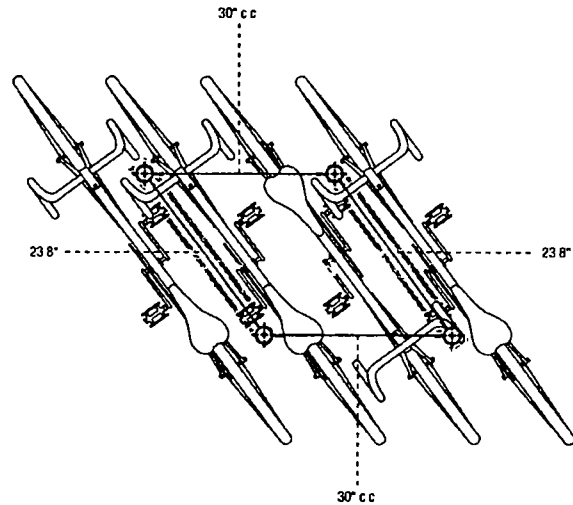

CONFIGURATION OPTION B





12/10/2014

Alderman **Harry Osterman**
Ward # **48**
City of Chicago
City Hall, Room **300**
121 North LaSalle Street
Chicago, Illinois 60602

Re: An ordinance to use and maintain a portion of the public right-of-way for **two (2) bicycle rack(s)** for
CHICAGO HOUSING AUTHORITY, adjacent to the premises known as **5040 N. Kenmore Ave..**

Dear Alderman **Harry Osterman**:

The applicant referenced above has requested the use of the public right-of-way for a **bicycle rack(s)**. An ordinance has been prepared by the Department of Business Affairs and Consumer Protection – Small Business Center - Public Way Use Unit for presentation to the City Council. Because this request was made for properties located in your ward, as approved by you as per the attached, I respectfully request that you introduce the attached ordinance at the next City Council meeting.

If you have any questions regarding this ordinance, please contact Anthony Bertuca at (312) 744-5506.

Department of Business Affairs and Consumer Protection