



City of Chicago



O2017-2752

Office of the City Clerk

Document Tracking Sheet

Meeting Date:	3/29/2017
Sponsor(s):	Reilly (42)
Type:	Ordinance
Title:	Canopy(s) for LMV River North Holdings LP
Committee(s) Assignment:	Committee on Transportation and Public Way

ORDINANCE
LMV RIVER NORTH HOLDINGS, LP
Acct. No. 414689 - 1
Permit No. 1126772

Be It Ordained by the City Council of the City of Chicago:

SECTION 1. Permission and authority are hereby given and granted to LMV RIVER NORTH HOLDINGS, LP, upon the terms and subject to the conditions of this ordinance to construct, install, maintain and use one (1) Canopy(s) projecting over the public right-of-way adjacent to its premises known as 675 N. Wells St..

Said Canopy(s) at W. Huron Street measure(s):

One (1) at nine point eight three (9.83) feet in length, and eight point two five (8.25) feet in width for a total of eighty-one point one (81.1) square feet.

The location of said privilege shall be as shown on prints kept on file with the Department of Business Affairs and Consumer Protection and the Office of the City Clerk.

Said privilege shall be constructed in accordance with plans and specifications approved by the Zoning Department - Signs.

This grant of privilege in the public way shall be subject to the provisions of Section 10-28-015 and all other required provisions of the Municipal Code of Chicago.

The grantee shall pay to the City of Chicago as compensation for the privilege #1126772 herein granted the sum of fifty (\$50.00) per annum in advance.

A 25% penalty will be added for payments received after due date.

The permit holder agrees to hold the City of Chicago harmless for any damage, relocation or replacement costs associated with damage, relocation or removal of private property caused by the City performing work in the public way.

Authority herein given and granted for a period of five (5) years from and after Date of Passage.

Alderman _____

Brendan Reilly 42nd Ward

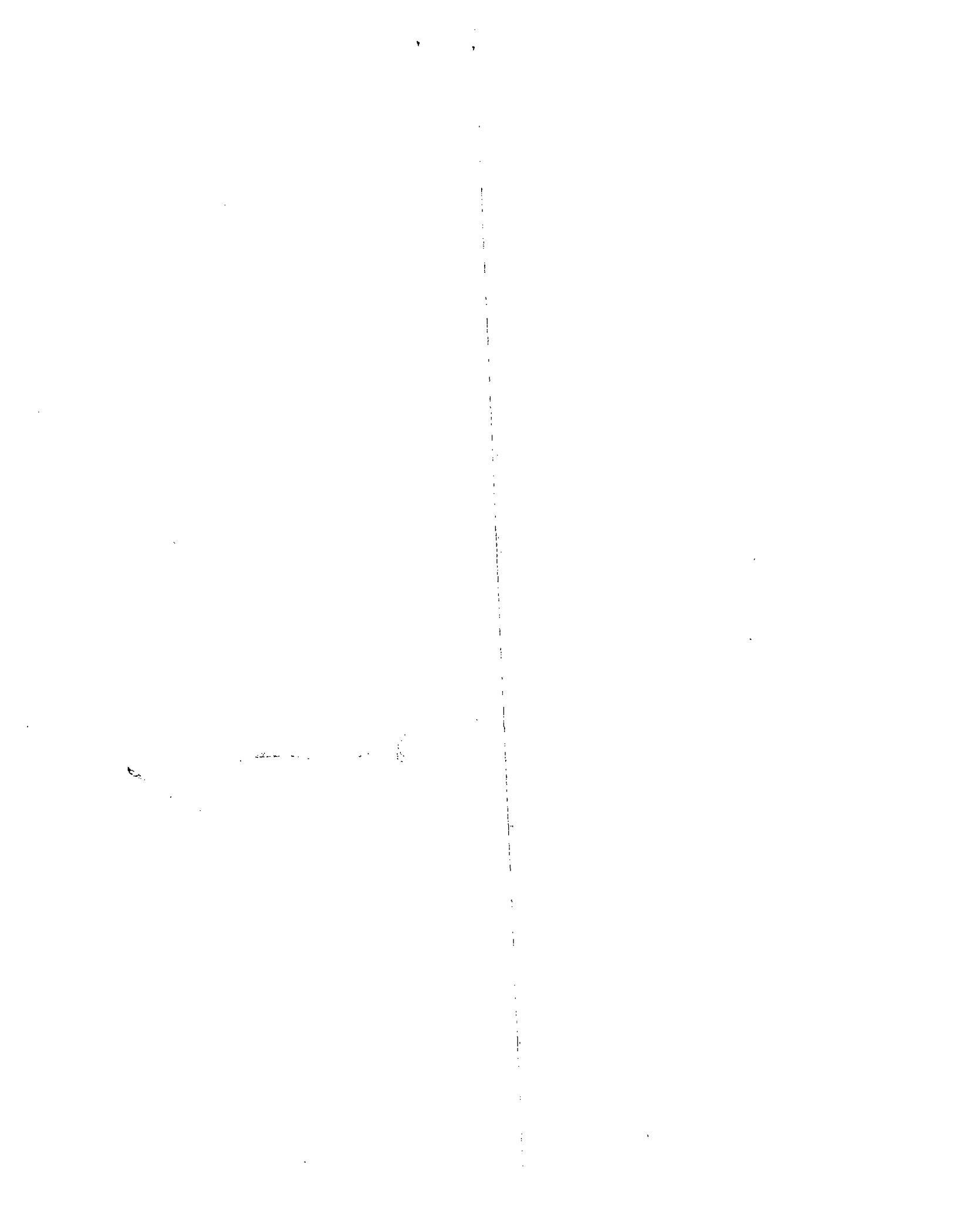

REVISIONS	
No.	Description
1	ISSUED FOR PERMITTING
2	REVISED PER PERMITTING
3	REVISED PER PERMITTING
4	REVISED PER PERMITTING
5	REVISED PER PERMITTING
6	REVISED PER PERMITTING
7	REVISED PER PERMITTING
8	REVISED PER PERMITTING
9	REVISED PER PERMITTING
10	REVISED PER PERMITTING

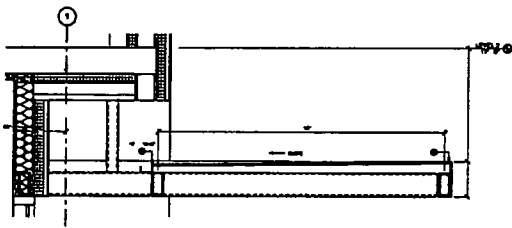

SECTION THROUGH WALL WINDOW

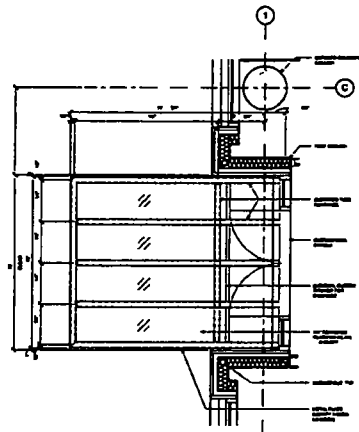

SECTION THROUGH WALL WINDOW

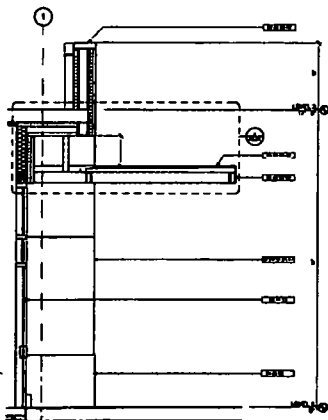

SECTION THROUGH WALL WINDOW

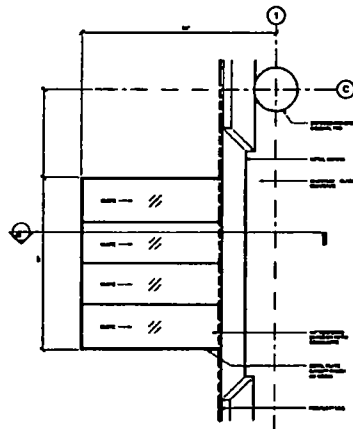

SECTION THROUGH WALL WINDOW

REVISIONS	
No.	Description
1	ISSUED FOR PERMITTING
2	REVISED PER PERMITTING
3	REVISED PER PERMITTING
4	REVISED PER PERMITTING
5	REVISED PER PERMITTING
6	REVISED PER PERMITTING
7	REVISED PER PERMITTING
8	REVISED PER PERMITTING
9	REVISED PER PERMITTING
10	REVISED PER PERMITTING

ANTONOVICH ASSOCIATES
ARCHITECTS
1000 W. WASHINGTON ST.
ANN ARBOR, MI 48106
TEL: 734.769.1234
WWW.ANTONOVICHASSOCIATES.COM

HURON AND WELLS
ARCHITECTS
1000 W. WASHINGTON ST.
ANN ARBOR, MI 48106
TEL: 734.769.1234
WWW.HURONANDWELLS.COM

ENLARGED RESIDENTIAL ENTRANCE CANOPY
A9.21

