



City of Chicago



O2013-4734

Office of the City Clerk

Document Tracking Sheet

Meeting Date:	6/5/2013
Sponsor(s):	Arena, John (45)
Type:	Ordinance
Title:	Grant(s) of privilege in public way for Chicago Sweet Connection Bakery
Committee(s) Assignment:	Committee on Transportation and Public Way

ORDINANCE
CHICAGO SWEET CONNECTION BAKERY
Acct. No. 212390 - 1
Permit No. 1105987

Be It Ordained by the City Council of the City of Chicago:

SECTION 1. Permission and authority are hereby given and granted to CHICAGO SWEET CONNECTION BAKERY, upon the terms and subject to the conditions of this ordinance to maintain and use, as now constructed, one (1) Manhole(s) under the public right-of-way adjacent to its premises known as 5569 N. Northwest Hwy..

Said Manhole(s) at N. MEADE measure(s):
One (1) at one (1) foot in length, and four (4) feet in width for a total of four (4) square feet.

The location of said privilege shall be as shown on prints kept on file with the Department of Business Affairs and Consumer Protection and the Office of the City Clerk.

Said privilege shall be constructed in accordance with plans and specifications approved by the Department of Transportation (Office of Underground Coordination) and Department of Water Management.

This grant of privilege in the public way shall be subject to the provisions of Section 10-28-015 and all other required provisions of the Municipal Code of Chicago.

The grantee shall pay to the City of Chicago as compensation for the privilege #1105987 herein granted the sum of four hundred (\$400.00) per annum in advance.

A 25% penalty will be added for payments received after due date.

The permit holder agrees to hold the City of Chicago harmless for any damage, relocation or replacement costs associated with damage, relocation or removal of private property caused by the City performing work in the public way.

Authority herein given and granted for a period of five (5) years from and after 10/31/2012.

Alderman _____

John Arena. 45th Ward

METROPOLITAN WATER RECLAMATION DISTRICT OF GREATER CHICAGO

Criteria for Compliance With Control Manhole/Sampling Chamber Installation and Access Requirements

TYPICAL CONTROL MANHOLE

(NOT TO SCALE)

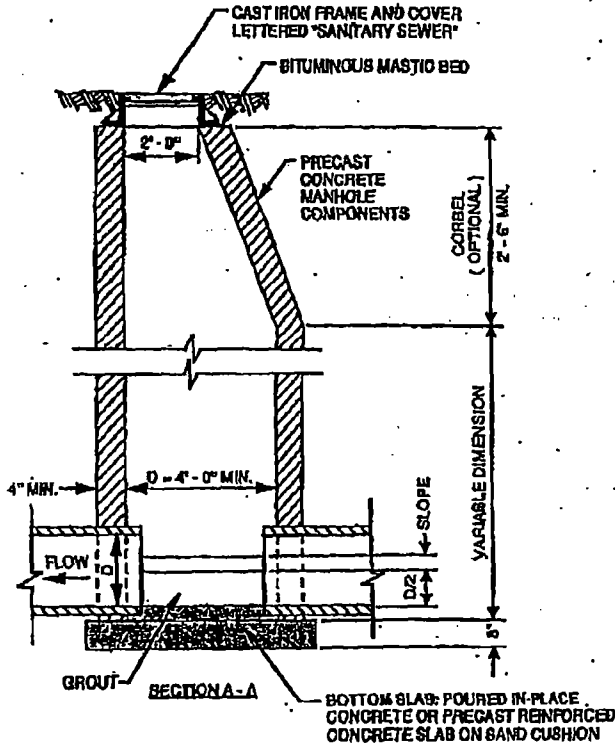

NOTE: 1. IN CASES WHERE A PRIMARY MEASURING DEVICE (PMD) IS PROVIDED, THE PMD SHOULD BE CENTERED DIRECTLY BELOW THE OPENING TO ENABLE VISUAL AND PHYSICAL ACCESS TO THE FLOW CHANNEL FROM GROUND LEVEL.

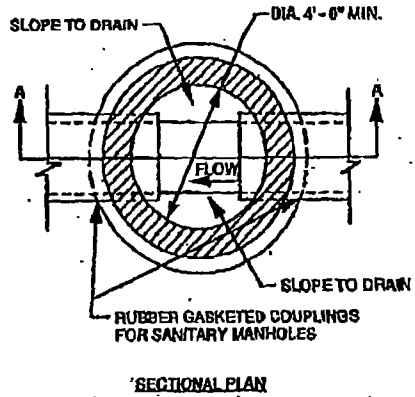

TOTAL P. 09

OCT. 1, 2007 9:56AM ALDERMAN PATRICK LEVY
JDF-28-2007 01:17 SCAFFALIS ASSOC.

NO. 087 P.B. P.09



06/05/2013

Alderman John Arena
Ward # 45
City of Chicago
City Hall, Room 305
121 North LaSalle Street
Chicago, Illinois 60602

Re: An ordinance to use and maintain a portion of the public right-of-way for **one (1) manhole(s)** for **CHICAGO SWEET CONNECTION BAKERY**, adjacent to the premises known as **5569 N. Northwest Hwy.**

Dear Alderman **John Arena**:

The applicant referenced above has requested the use of the public right-of-way for a **manhole(s)**. An ordinance has been prepared by the Department of Business Affairs and Consumer Protection – Business Assistance Center - Public Way Use Unit for presentation to the City Council. Because this request was made for properties located in your ward, as approved by you as per the attached, I respectfully request that you introduce the attached ordinance at the next City Council meeting.

If you have any questions regarding this ordinance, please contact Anthony Bertuca at (312) 744-5506.

Department of Business Affairs and Consumer Protection