



City of Chicago



O2014-3844

Office of the City Clerk

Document Tracking Sheet

Meeting Date:	4/30/2014
Sponsor(s):	Osterman (48)
Type:	Ordinance
Title:	Grant(s) of privilege in public way for Sleepy's
Committee(s) Assignment:	Committee on Transportation and Public Way

ORDINANCE
SLEEPY'S
Acct. No. 381413 - 18
Permit No. 1110846

Be It Ordained by the City Council of the City of Chicago:

SECTION 1. Permission and authority are hereby given and granted to SLEEPY'S, upon the terms and subject to the conditions of this ordinance to maintain and use three (3) sign(s) projecting over the public right-of-way attached to its premises known as 1134 W. Granville Ave..

Said sign structure(s) measures as follows; along W. Granville:

One (1) at fourteen point zero eight (14.08) feet in length, one point five (1.5) feet in height and eleven point five (11.5) feet above grade level.

One (1) at twenty-eight point three three (28.33) feet in length, three (3) feet in height and fourteen point two five (14.25) feet above grade level.

One (1) at twenty-eight point three three (28.33) feet in length, one point five (1.5) feet in height and fourteen point six seven (14.67) feet above grade level.

The location of said privilege shall be as shown on prints kept on file with the Department of Business Affairs and Consumer Protection and the Office of the City Clerk

Said privilege shall be constructed in accordance with plans and specifications approved by the Department of Transportation (Division of Project Development) and Zoning Department- Signs.

This grant of privilege in the public way shall be subject to the provisions of Section 10-28-015 and all other required provisions of the Municipal Code of Chicago.

The grantee shall pay to the City of Chicago as compensation for the privilege #1110846 herein granted the sum of seven hundred (\$700.00) per annum in advance.

A 25% penalty will be added for payments received after due date

The permit holder agrees to hold the City of Chicago harmless for any damage, relocation or replacement costs associated with damage, relocation or removal of private property caused by the City performing work in the public way.

Authority herein given and granted for a period offive (5) years from and after Date of Passage.

Alderman _____

~~Joe Moore 49th Ward~~

Harry Osborne, 48

SIGN B	36" Sloppy's / 16" TMP
Type	Channel Letters on a Raceway / Cabinet
Illumination:	Internally Illuminated LED
Square Footage:	145.42
To Grade:	Top of sign to grade = 19'-5 1/4" Bottom of sign to grade = 14'-3 1/4"

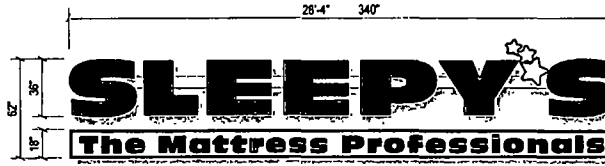

Specifications: LED Channel Letters / "Star"

- Existing Facade, Block
- 0 040" Aluminum letter returns painted to match Black
- 0 125" x 1" Black Jewelite Inncap
- 3mm Signabond Lite composite backs
(interior of sign can painted ultra white for maximum illumination)
- Letters- Sloan Value Line Plus Short Red LED modules
- Star- Sloan Value Line Plus Short White LEDs
- Letters- 3/16" 2415 Red LD acrylic
Star- 3/16" 2447 White LD acrylic w/ Vinyl 3M 3630-125 Golden Yellow vinyl with 3M 7125-22 Matte Black vinyl outline
- Waterproof disconnect switch per NEC 600-8
- Primary electrical feed
- Transformers
- 0 080" Raceway (5 1/2" tall x 3 1/2" deep fabricated aluminum) Painted to match facade
- 9" x 2" x 0.1875" Aluminum mounting tabs welded to raceway
- Maximum 8" from each end and every 48" o c
- #12 x 1" TEC screws with 11/4" fender washers
- Mounting hardware to suit

Electrical Detail: Channel Letters/ Cabinet

White Sloan Value Line Plus
(4) 60w Transformers @ 0 85
Total Amps 3 40
(1) 20 amp 120V Circuit Req



General Notes:

- This sign is to be installed in accordance with the requirements of Article 600 of the National Electrical Code
- Grounded and bonded per NEC 600.7/NEC 250
 - Existing branch circuit in compliance with NEC 600 5, not to exceed 20 amps
 - Sign is to be UL listed per NEC 600 3
 - UL disconnect switch per NEC 600 6- required per sign component before leaving manufacturer
*For multiple signs, a disconnect is permitted but not required for each section

Specifications: TMP Cabinet (LED illumination)

- Existing Facade, Block
- 0.050" (5" Deep) Aluminum sign cabinet painted to match Black
- 1 1/2" x 1 1/2" Aluminum angle retainers painted to match Black
- 1 1/2" x 1 1/2" Internal Aluminum angle frame
- 3/16" 7328 White LD acrylic or 3M Panagraphics III flex face w/ applied 3M 3630-22 Black vinyl copy
- LEDs & Transformer- Sloan Value Line Plus Short White LEDs
- Waterproof disconnect switch
- Primary electrical feed
- Mounting hardware to suit

Sign Layout Detail

Scale 3/16" = 1'-0"

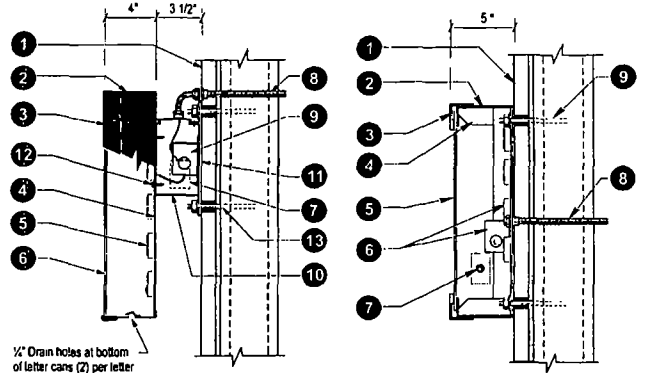

Section @ LED Channel Letter Raceway (Upper)
Scale N.T.S.

Section @ S/F Wall Sign LEDs
Scale: N.T.S.



Client: Sleepy's
Site #. SY-A17898
Address 1134 West Granville Avenue, Space 2A
Chicago, IL 60660
Clarevista

REVISION NO.	DATE	DESCRIPTION	BY
0	01/19/2013	Original Rendering	PM
1	02/25/2013	Created new sign for 1134 B	PM
2	10/09/2013	Updated Sign A placement on facade, changed Sign B Opt 1 to white CLs	NK
3	10/07/2013	Revised All CLs to Red	SD
4	11/07/2013	Remove OPTION 1 for SIGN B Add an awning below SIGN A with TMP on the valance	SW

This rendering is the property of Anchor Sign, Inc. It is for the exclusive use of Anchor Sign, Inc. and the party which requested this rendering. It is an unpublished copyright drawing not to be distributed, reproduced or exhibited without the consent of Anchor Sign, Inc. Please contact your Anchor Sign representative regarding this document.

AnchorSign
1 800 213 3331



04/02/2014

Alderman Joe Moore
Ward # 49
City of Chicago
City Hall, Room 300
121 North LaSalle Street
Chicago, Illinois 60602

Re: An ordinance to use and maintain a portion of the public right-of-way for **three (3) sign(s)** for **SLEEPY'S**, adjacent to the premises known as **1134 W. Granville Ave.**

Dear Alderman **Joe Moore**:

The applicant referenced above has requested the use of the public right-of-way for a **sign(s)**. An ordinance has been prepared by the Department of Business Affairs and Consumer Protection – Small Business Center - Public Way Use Unit for presentation to the City Council. Because this request was made for properties located in your ward, as approved by you as per the attached, I respectfully request that you introduce the attached ordinance at the next City Council meeting.

If you have any questions regarding this ordinance, please contact Anthony Bertuca at (312) 744-5506.

Department of Business Affairs and Consumer Protection