



City of Chicago



O2014-3608

Office of the City Clerk

Document Tracking Sheet

Meeting Date: 4/30/2014
Sponsor(s): Reilly (42)
Type: Ordinance
Title: Grant(s) of privilege in public way for Integrated Clark
Monroe - door swings
Committee(s) Assignment: Committee on Transportation and Public Way

ORDINANCE
INTEGRATED CLARK MONROE
Acct. No. 389327 - 1
Permit No. 1112251

Be It Ordained by the City Council of the City of Chicago:

SECTION 1. Permission and authority are hereby given and granted to INTEGRATED CLARK MONROE, upon the terms and subject to the conditions of this ordinance to construct, install, maintain and use two (2) Door Swing(s) projecting over the public right-of-way adjacent to its premises known as 100 W. Monroe St..

Said Door Swing(s) at Rear Alley (100 W Monroe) measure(s):

Two (2) at six point four two (6.42) feet in length, and seven (7) feet in width for a total of eighty-nine point eight eight (89.88) square feet.

The location of said privilege shall be as shown on prints kept on file with the Department of Business Affairs and Consumer Protection and the Office of the City Clerk.

Said privilege shall be constructed in accordance with plans and specifications approved by the Department of Transportation (Division of Project Development).

This grant of privilege in the public way shall be subject to the provisions of Section 10-28-015 and all other required provisions of the Municipal Code of Chicago.

The grantee shall pay to the City of Chicago as compensation for the privilege #1112251 herein granted the sum of one hundred fifty (\$150.00) per annum in advance.

A 25% penalty will be added for payments received after due date.

The permit holder agrees to hold the City of Chicago harmless for any damage, relocation or replacement costs associated with damage, relocation or removal of private property caused by the City performing work in the public way.

Authority herein given and granted for a period of five (5) years from and after Date of Passage.

Alderman _____

Brendan Reilly 42nd Ward

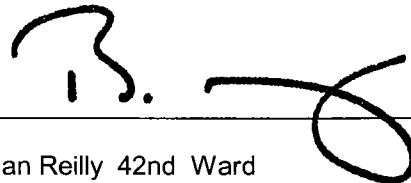

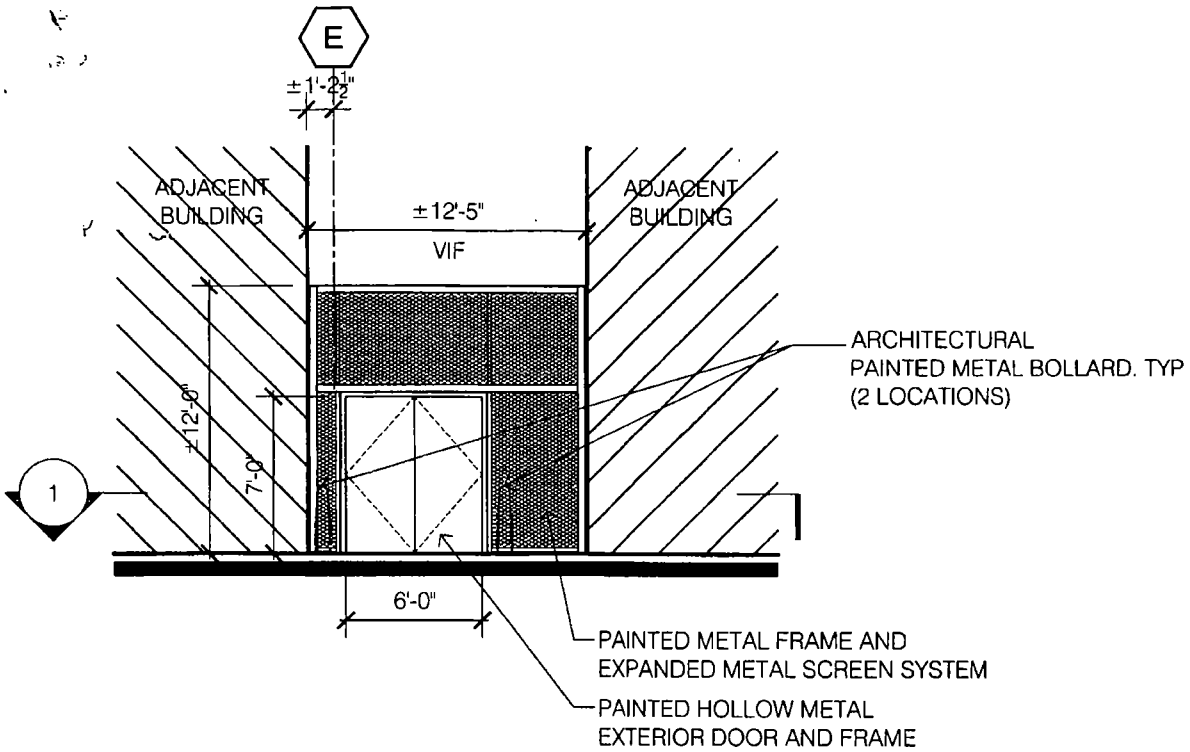

2 PARTIAL ELEVATION

SCALE: 1/8" = 1'-0"

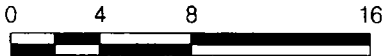

1/8" = 1'-0"

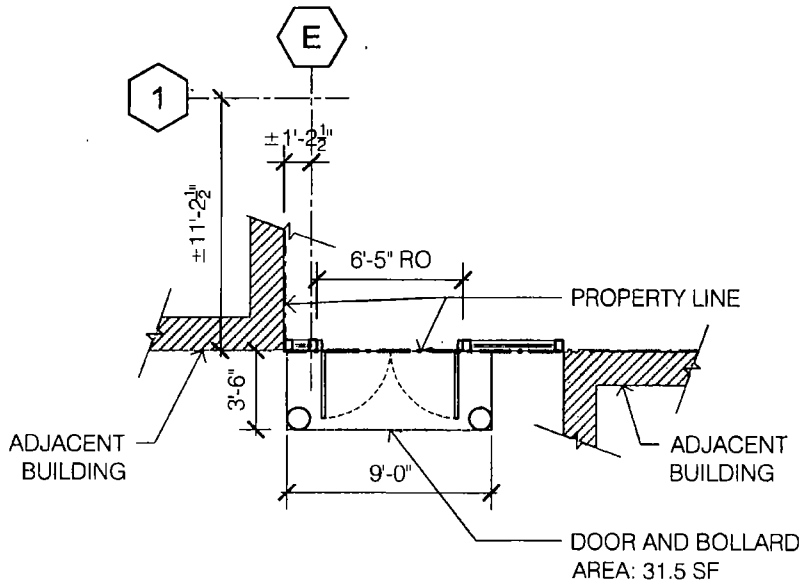

1 PARTIAL PLAN

SCALE: 1/8" = 1'-0"

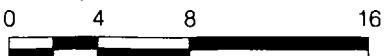

1/8" = 1'-0"

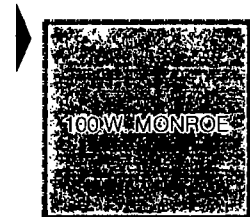

S. CLARK ST.

WEST MONROE ST.

