



City of Chicago



O2019-2972

Office of the City Clerk

Document Tracking Sheet

Meeting Date:	4/10/2019
Sponsor(s):	Smith (43)
Type:	Ordinance
Title:	Awning(s) for Pure Serenity Spa
Committee(s) Assignment:	Committee on Transportation and Public Way

ORDINANCE
PURE SERENITY SPA
Acct. No. 428248 - 1
Permit No. 1137372

Be It Ordained by the City Council of the City of Chicago:

SECTION 1. Permission and authority are hereby given and granted to PURE SERENITY SPA, upon the terms and subject to the conditions of this ordinance to construct, install, maintain and use two (2) Awning(s) projecting over the public right-of-way adjacent to its premises known as 1136 W. Armitage Ave..

Said Awning(s) at W ARMITAGE measure(s):

One (1) at ten point five (10.5) feet in length, and two (2) feet in width for a total of twenty-one (21) square feet.

Said Awning(s) at N CLINTON ST measure(s):

One (1) at six point four two (6.42) feet in length, and two (2) feet in width for a total of twelve point eight four (12.84) square feet.

The location of said privilege shall be as shown on prints kept on file with the Department of Business Affairs and Consumer Protection and the Office of the City Clerk.

Said privilege shall be constructed in accordance with plans and specifications approved by the Zoning Department - Signs.

This grant of privilege in the public way shall be subject to the provisions of Section 10-28-015 and all other required provisions of the Municipal Code of Chicago.

The grantee shall pay to the City of Chicago as compensation for the privilege #1137372 herein granted the sum of one hundred (\$100.00) per annum in advance.

A 25% penalty will be added for payments received after due date.

The permit holder agrees to hold the City of Chicago harmless for any damage, relocation or replacement costs associated with damage, relocation or removal of private property caused by the City performing work in the public way.

Authority herein given and granted for a period of five (5) years from and after Date of Passage.

Alderman

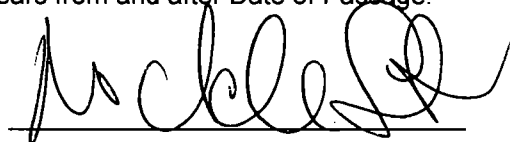

Michele Smith 43rd Ward

SIGN 1: AWNING



FABRIC MATERIAL
SUNBRELLA - BLACK (page 18)

*ACTUAL COLOR TO BE DETERMINED BY CUSTOMER

SPECIFICATIONS

COLOR SCHEDULE

MOUNTING DETAIL

- 1 AWNING FABRIC MATERIAL
- 2 1 X 1 SQUARE TUBE FRAME
- 3 3/16 GALVANIZED STEEL Z-CLIP ATTACHMENT
- 4 APPROPRIATE NON CORROSIVE WALL FASTENER
3/8 IN ZINC-PLATED HEX LAG SCREW
SPACING EACH 4 FT
SEE MOUNTING OPTION DETAILS
- 5 #12 TEK SCREW

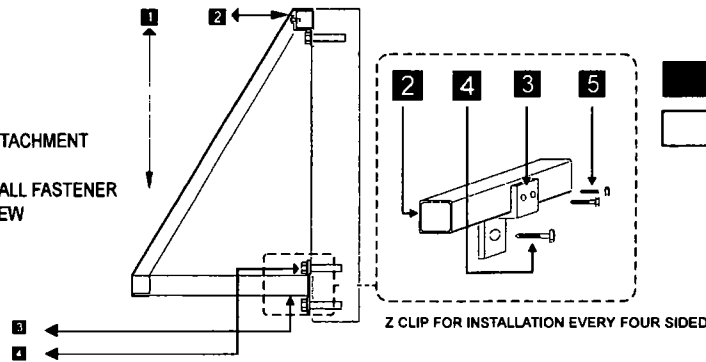

Thru-Bolt Mounting

Hanger Bolts

Reverse Toggle Bolt Mounting

Masonry Lag Bolt Mounting



Client Name
Pure Serenity Spa

Location
1134 W Armitage Ave
Chicago IL 60614

Start Date 10/16/2018

Last Revision

Job#

Drawing#

Page 4

- Client Approval
- Landlord Approval

Sales Rep
kw
Designer
SL

