

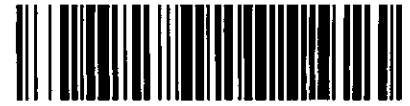

Office of the Chicago City
Clerk



O2011-8989

Office of the City Clerk

City Council Document Tracking Sheet

Meeting Date: 11/2/2011
Sponsor(s): Brookins, Howard (21)
Type: Ordinance
Title: Grant(s) of Privilege in Public Way for Family Dollar No.
5630 - 1098165
Committee(s) Assignment: Committee on Transportation and Public Way

ORDINANCE
FAMILY DOLLAR #5630
Acct. No. 11071 - 48
Permit No. 1098165

Be It Ordained by the City Council of the City of Chicago:

SECTION 1. Permission and authority are hereby given and granted to FAMILY DOLLAR #5630, upon the terms and subject to the conditions of this ordinance to maintain and use one (1) sign(s) projecting over the public right-of-way attached to its premises known as 8030 S. Halsted St..

Said sign structure(s) measures as follows; along S. Halsted:

One (1) at twenty-five point zero eight (25.08) feet in length, three point eight three (3.83) feet in height and fifteen (15) feet above grade level.

The location of said privilege shall be as shown on prints kept on file with the Department of Business Affairs and Consumer Protection and the Office of the City Clerk.

Said privilege shall be constructed in accordance with plans and specifications approved by the Department of Transportation (Division of Project Development) and Zoning Department - Signs.

This grant of privilege in the public way shall be subject to the provisions of Section 10-28-015 and all other required provisions of the Municipal Code of Chicago.

The grantee shall pay to the City of Chicago as compensation for the privilege #1098165 herein granted the sum of three hundred (\$300.00) per annum in advance.

A 25% penalty will be added for payments received after due date.

The permit holder agrees to hold the City of Chicago harmless for any damage, relocation or replacement costs associated with damage, relocation or removal of private property caused by the City performing work in the public way.

Authority herein given and granted for a period of five (5) years from and after Date of Passage.

Alderman



Howard Brookins, Jr. 21st Ward

Family Dollar Design Drawings

34.5" Cloud Sign w/ 46" Medallion

SIGN WEIGHT = 450 LBS.
SIGN AREA = 74.76 SQ. FT.

FACE MATERIAL BURN RATE:
UL 94 FLAM CLASS RATING-94V-2

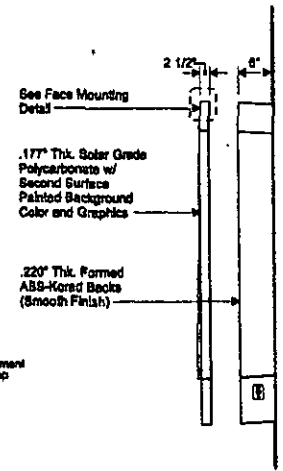
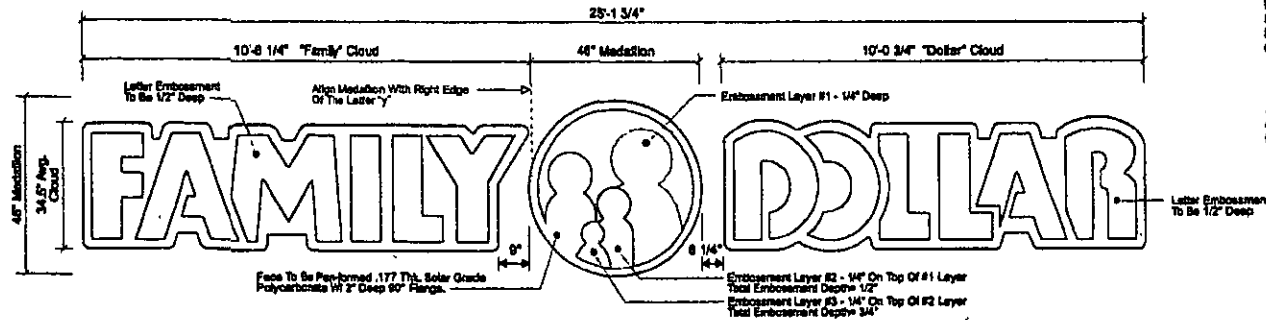

Project Information		
Client	FASTBREAK	
Location	8035 S. Halsted Street Chicago, IL	
For	FD-C FASTBREAK-711-6630_Chicago IL	
Date	Design	Project Manager
10/26/11	DJB	MP
Date / Description		
11/28/11	Install Onsite	

Client Review Status		
Allen Industries, Inc. warrants that an "Approved" drawing has obtained from the client prior to any production release or production release revision.		
<input type="checkbox"/> Approved	<input type="checkbox"/> Approved as Noted	<input type="checkbox"/> Revise & Resubmit
Name	Date	

Notes	

This is an original unpublished drawing, created by Allen Industries, Inc. It is intended for your personal use in connection with the project being prepared for you by Allen Industries, Inc. It is not to be shown to anyone outside your organization, not used, reproduced, copied or exhibited in any fashion whatsoever. All or part of this design (except for registered trademarks) remains the property of Allen Industries, Inc.

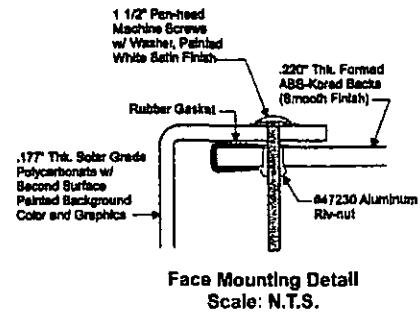

- Color Reference:**
- Red
Akzo Nobel (Grip Flex) SIGN0208
 - Orange
Akzo Nobel (Grip Flex) SIGN0290
 - White
Akzo Nobel (Grip Flex) SIGN10398

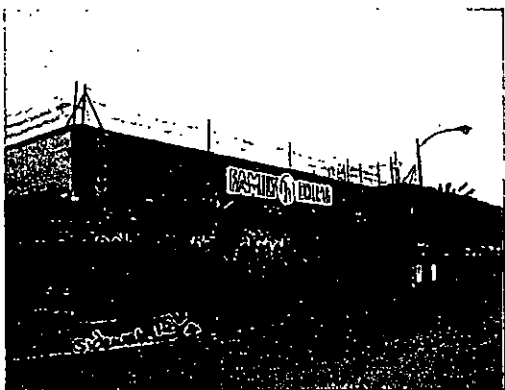
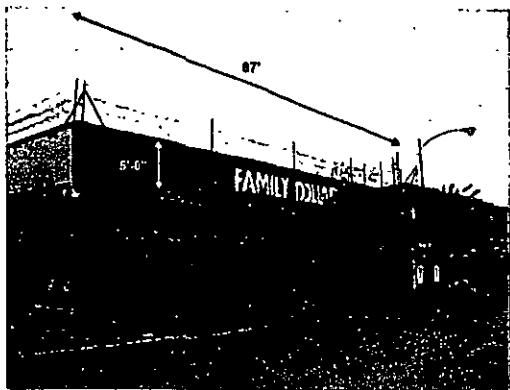

6.3 AMPS TOTAL

UL LISTED
ELECTRIC SIGN

Allen Industries
Corporate Identity Programs

Corporate Headquarters
6434 Burnt Poplar Road, Greensboro, NC 27409
Phone 800-867-2553 Fax 336-668-7875

Because Image Is Everything™



11/02/2011

Alderman **Howard Brookins, Jr.**
Ward # 21
City of Chicago
City Hall, Room 300
121 North LaSalle Street
Chicago, Illinois 60602

Re: An ordinance to use and maintain a portion of the public right-of-way for **one (1) sign(s)** for
FAMILY DOLLAR #5630, adjacent to the premises known as **8030 S. Halsted St.**

Dear Alderman **Howard Brookins, Jr.:**

The applicant referenced above has requested the use of the public right-of-way for a **sign(s)**. An ordinance has been prepared by the Department of Business Affairs and Consumer Protection – Business Assistance Center - Public Way Use Unit for presentation to the City Council. Because this request was made for properties located in your ward, as approved by you as per the attached, I respectfully request that you introduce the attached ordinance at the next City Council meeting.

If you have any questions regarding this ordinance, please contact Anthony Bertuca at (312) 744-5506.

Department of Business Affairs and Consumer Protection