



City of Chicago



O2020-717

Office of the City Clerk

Document Tracking Sheet

Meeting Date:	2/11/2020
Sponsor(s):	Sigcho-Lopez (25)
Type:	Ordinance
Title:	Grant(s) of privilege in public way for Meet Noodles
Committee(s) Assignment:	Committee on Transportation and Public Way

Direct Intro

#25

ORDINANCE
MEET NOODLES
Acct. No. 464927 - 1
Permit No. 1143306

Be It Ordained by the City Council of the City of Chicago:

SECTION 1. Permission and authority are hereby given and granted to MEET NOODLES, upon the terms and subject to the conditions of this ordinance to maintain and use one (1) sign(s) projecting over the public right-of-way attached to its premises known as 2026 S. Clark St..

Said sign structure(s) measures as follows; along S CLARK ST:

One (1) at thirteen point two five (13.25) feet in length, five point one seven (5.17) feet in height and eleven (11) feet above grade level.

The location of said privilege shall be as shown on prints kept on file with the Department of Business Affairs and Consumer Protection and the Office of the City Clerk.

Said privilege shall be constructed in accordance with plans and specifications approved by the Department of Transportation (Division of Project Development) and Zoning Department - Signs.

This grant of privilege in the public way shall be subject to the provisions of Section 10-28-015 and all other required provisions of the Municipal Code of Chicago.

The grantee shall pay to the City of Chicago as compensation for the privilege #1143306 herein granted the sum of three hundred (\$300.00) per annum in advance.

A 25% penalty will be added for payments received after due date.

The permit holder agrees to hold the City of Chicago harmless for any damage, relocation or replacement costs associated with damage, relocation or removal of private property caused by the City performing work in the public way.

Authority herein given and granted for a period of five (5) years from and after Date of Passage.

Alderman _____

Byron Sigcho-Lopez 25th Ward

SIGN 1: INTERNALLY ILLUMINATED CHANNEL LETTER

Front & Back Lit, Channel Letters w/ LED, Flush Mounted

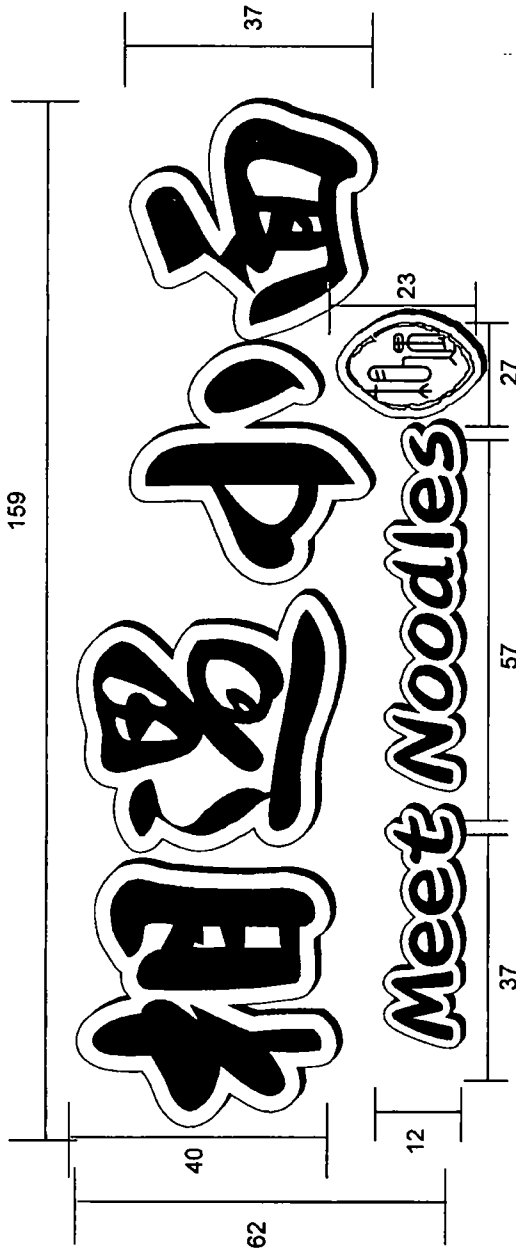

SPECIFICATIONS

Area	62" H x 159" W
Total Sq Ft.	68.46 ft ²
Returns	Black
Trimcap	Black
Illumination	White LED
Face	White, Black, Red

TO BE CONFIRM

FRONT & BACK-LIT CHANNEL LETTER - TYPICAL SECTION - FLUSH MOUNTED

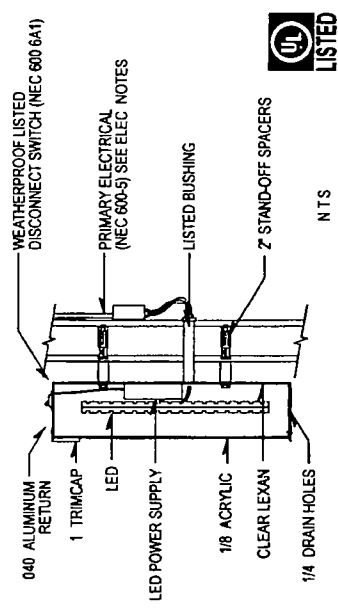

Grounding and Bonding Statement
 This sign is intended to be installed in accordance with the requirements of Article 250 of the National Electrical Code and other applicable codes. This includes proper grounding and bonding of this sign.

ELECTRICAL NOTES

1. Sign Company (PMS) will provide primary electrical sign power for this sign. Must be done by a licensed electrician.
2. (Each sign must have)
3. A minimum of one electrical 120V/20A circuit
4. Junction box installed within 6 feet of sign
5. Three wires (line, ground, neutral)

NOTE Elevation drawings are for customer approval only, drawings are not to be used as any installation guide, all dimensions must be verified before installation. Color output may not be exact when viewing or printing this drawing. All colors used are PMS or the closest CMYK.

	Client Name Meet Noodles	Start Date 10/25/19	Sales Rep KW
	Location 2026 S Clark St unit F Chicago IL 60616	Last Revision 11/04/19	Designer Simon L
Client Approval		Drawing#	
Landlord Approval		Page 3/4	



Department of Business Affairs and Consumer Protection
Small Business Center - Public Way Use Unit
City Hall - 121 N. LaSalle Street, Room 800 • Chicago, IL 60602
312-74-GOBIZ / 312-744-6249 • (312) 744-1944 (TTY)
<http://www.cityofchicago.org/bacp>

01/15/2020

Alderman Byron Sigcho-Lopez
Ward # 25
City of Chicago
City Hall, Room 304
121 North LaSalle Street
Chicago, Illinois 60602

Re: An ordinance to use and maintain a portion of the public right-of-way for **one (1) sign(s)** for **MEET NOODLES**, adjacent to the premises known as **2026 S. Clark St.**.

Dear Alderman **Byron Sigcho-Lopez**:

The applicant referenced above has requested the use of the public right-of-way for a **sign(s)**. An ordinance has been prepared by the Department of Business Affairs and Consumer Protection – Small Business Center - Public Way Use Unit for presentation to the City Council. Because this request was made for properties located in your ward, as approved by you as per the attached, I respectfully request that you introduce the attached ordinance at the next City Council meeting.

If you have any questions regarding this ordinance, please contact Anthony Bertuca at (312) 744-5506.

Department of Business Affairs and Consumer Protection