



City of Chicago



O2018-1475

Office of the City Clerk

Document Tracking Sheet

Meeting Date:	2/28/2018
Sponsor(s):	Santiago (31)
Type:	Ordinance
Title:	Awning(s) for Structure Realty LLC
Committee(s) Assignment:	Committee on Transportation and Public Way

ORDINANCE
Structure Realty LLC
Acct. No. 422171 - 1
Permit No. 1129933

Be It Ordained by the City Council of the City of Chicago:

SECTION 1. Permission and authority are hereby given and granted to Structure Realty LLC, upon the terms and subject to the conditions of this ordinance to construct, install, maintain and use one (1) Awning(s) projecting over the public right-of-way adjacent to its premises known as 5342 W. Diversey Ave..

Said Awning(s) at W. Diversey measure(s):

One (1) at seventeen point four two (17.42) feet in length, and four (4) feet in width for a total of sixty-nine point six eight (69.68) square feet.

The location of said privilege shall be as shown on prints kept on file with the Department of Business Affairs and Consumer Protection and the Office of the City Clerk.

Said privilege shall be constructed in accordance with plans and specifications approved by the Zoning Department - Signs.

This grant of privilege in the public way shall be subject to the provisions of Section 10-28-015 and all other required provisions of the Municipal Code of Chicago.

The grantee shall pay to the City of Chicago as compensation for the privilege #1129933 herein granted the sum of fifty (\$50.00) per annum in advance.

A 25% penalty will be added for payments received after due date.

The permit holder agrees to hold the City of Chicago harmless for any damage, relocation or replacement costs associated with damage, relocation or removal of private property caused by the City performing work in the public way.

Authority herein given and granted for a period of five (5) years from and after Date of Passage.

Alderman

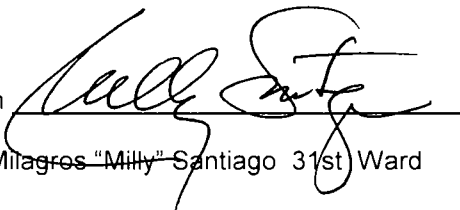

Milagros "Milly" Santiago 31st Ward

AWNING

CROSS SECTION DETAIL

Installation Detail

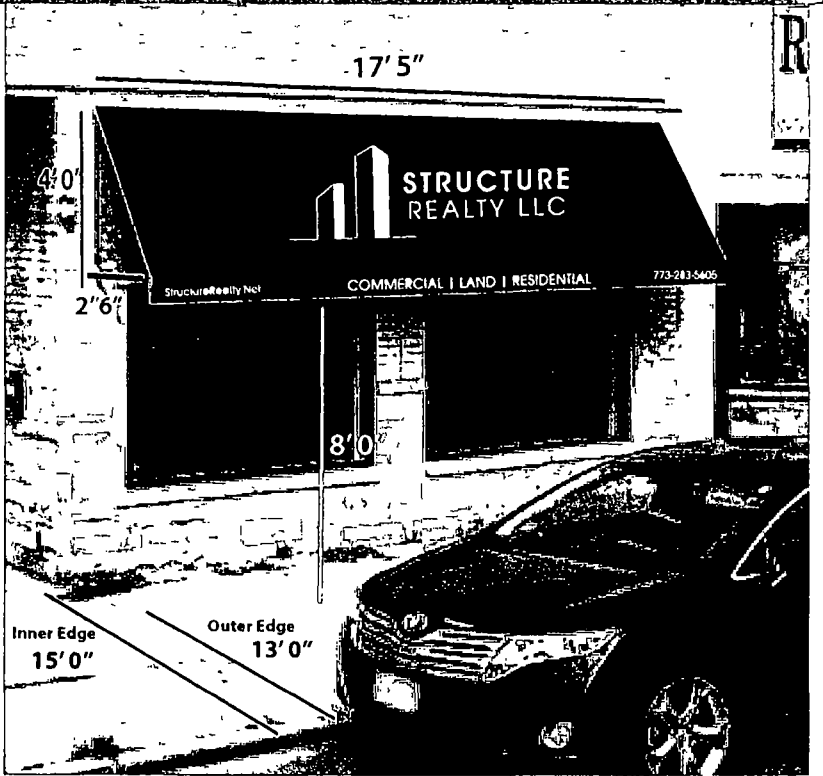
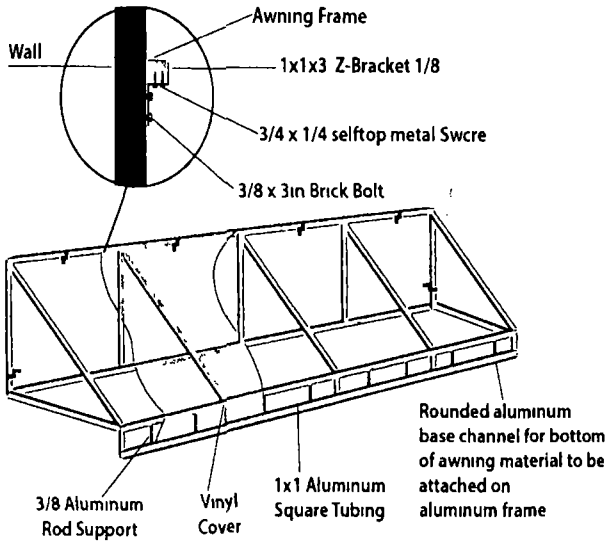

NOTE Photo for representational purposes only Signs are not to scale and may appear larger or smaller than shown

Sign Erector PRO IMAGE 2006 W. Chicago, Ave. Chicago, IL 60622 Tel. 773 292 1111 Fax. 773 645 4169	Location SOUTH ELEVATION	Description - ALUMINUM FRAMED AWNING - PRINTED TXT IN WHITE - 13 oz BLACK CANVAS - WALL MOUNTED - READS STRUCTURE REALTY LLC
	Address 5342 W Diversey Ave Chicago, IL 60639	Date 9-21-2017



Department of Business Affairs and Consumer Protection
Small Business Center - Public Way Use Unit
City Hall - 121 N LaSalle Street, Room 800 • Chicago, IL 60602
312-74-GOBIZ / 312-744-6249 • (312) 744-1944 (TTY)
<http://www.cityofchicago.org/bacp>

02/28/2018

Alderman **Milagros “Milly” Santiago**
Ward # **31**
City of Chicago
City Hall, Room **300**
121 North LaSalle Street
Chicago, Illinois 60602

Re: An ordinance to use and maintain a portion of the public right-of-way for **one (1) awning(s)** for **Structure Realty LLC**, adjacent to the premises known as **5342 W. Diversey Ave.**.

Dear Alderman **Milagros “Milly” Santiago**:

The applicant referenced above has requested the use of the public right-of-way for a **awning(s)**. An ordinance has been prepared by the Department of Business Affairs and Consumer Protection – Small Business Center - Public Way Use Unit for presentation to the City Council. Because this request was made for properties located in your ward, as approved by you as per the attached, I respectfully request that you introduce the attached ordinance at the next City Council meeting.

If you have any questions regarding this ordinance, please contact Anthony Bertuca at (312) 744-5506.

Department of Business Affairs and Consumer Protection