



City of Chicago



O2014-3745

Office of the City Clerk

Document Tracking Sheet

Meeting Date:	4/30/2014
Sponsor(s):	Burnett (27)
Type:	Ordinance
Title:	Grant(s) of privilege in public way for Gerber Auto Collison
Committee(s) Assignment:	Committee on Transportation and Public Way

ORDINANCE
GERBER AUTO COLLISON
Acct. No. 31059 - 4
Permit No. 1111399

Be It Ordained by the City Council of the City of Chicago:

SECTION 1. Permission and authority are hereby given and granted to GERBER AUTO COLLISON, upon the terms and subject to the conditions of this ordinance to maintain and use one (1) sign(s) projecting over the public right-of-way attached to its premises known as 1060 W. Huron St..

Said sign structure(s) measures as follows; along W HURON ST:
One (1) at eight (8) feet in length, four point three three (4.33) feet in height and ten (10) feet above grade level.

The location of said privilege shall be as shown on prints kept on file with the Department of Business Affairs and Consumer Protection and the Office of the City Clerk.

Said privilege shall be constructed in accordance with plans and specifications approved by the Department of Transportation (Division of Project Development) and Zoning Department - Signs.

This grant of privilege in the public way shall be subject to the provisions of Section 10-28-015 and all other required provisions of the Municipal Code of Chicago.

The grantee shall pay to the City of Chicago as compensation for the privilege #1111399 herein granted the sum of three hundred (\$300.00) per annum in advance.

A 25% penalty will be added for payments received after due date.

The permit holder agrees to hold the City of Chicago harmless for any damage, relocation or replacement costs associated with damage, relocation or removal of private property caused by the City performing work in the public way.

Authority herein given and granted for a period of five (5) years from and after Date of Passage.

Alderman

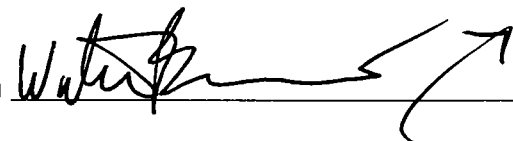
A handwritten signature in black ink, appearing to read 'Walter Burnett Jr.', written over a horizontal line. The signature is stylized and includes a long, sweeping flourish that extends to the right and slightly upwards.

Walter Burnett Jr. 27th Ward

10/10/10

S1

Raceway Mounted Face-lit Letterset

Remove existing letterset & repair metal façade to like new condition. Install new internally illuminated, raceway mounted face-lit letterset. Letter returns to be fabricated from .040" aluminum and painted white; letter backs to be routed .080" aluminum. Paint letter interiors Spraylat Star-Brite White EF. Letter faces to be white acrylic with standard vinyls applied. Secured faces to letter returns with white plastic trim caps and painted screws. Illuminate letters using white LED's. Raceways painted to match existing fascia color.

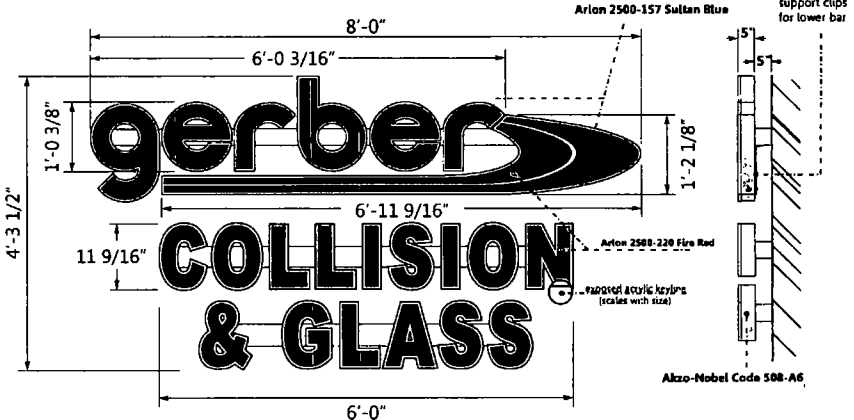
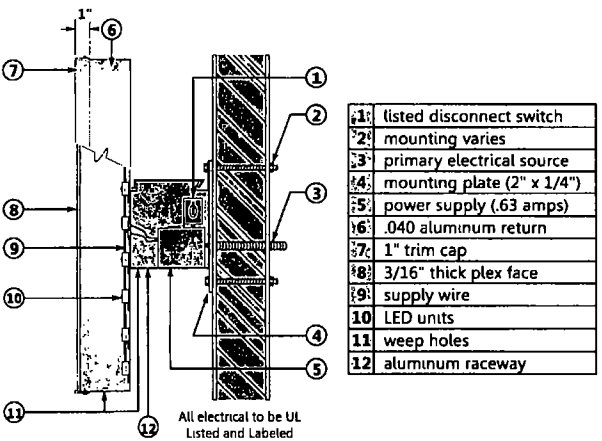
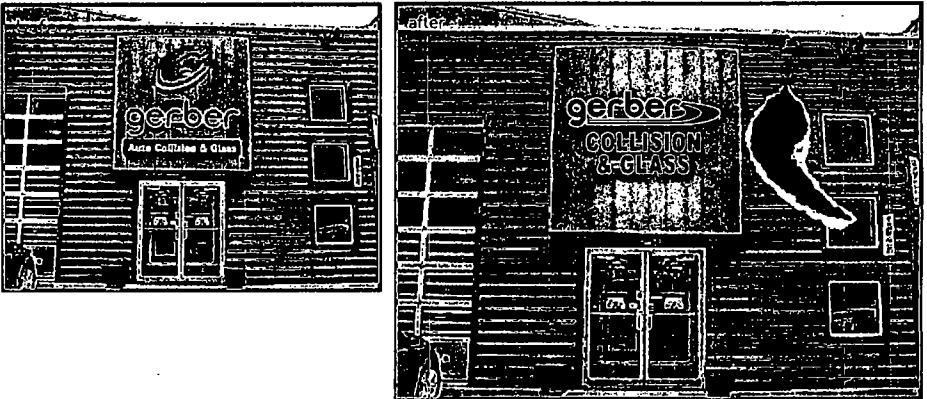

part # sf
 {custom}GCC-FR-DS-3433



Revisions		
Revised sign / 06/09/11/PL	1	
Revised to new layout / 06/29/11/PL	1	
	1	

File Location
 Ar\Draw\Color\05 04 13

Date 05 04 13
 Designer EPL PM NS

City/State Chicago IL
 Address 1060 W Huron

Drawing # C37279-S1
 Site Name -