



City of Chicago



O2019-6249

Office of the City Clerk

Document Tracking Sheet

Meeting Date:	7/24/2019
Sponsor(s):	Smith (43)
Type:	Ordinance
Title:	Grant(s) of privilege in public way for Hines/McCaffery Condo Manager LLC - light poles
Committee(s) Assignment:	Committee on Transportation and Public Way

ORDINANCE
HINES/McCAFFERY CONDO MANAGER LLC
Acct. No. 430245 - 2
Permit No. 1141011

Be It Ordained by the City Council of the City of Chicago:

SECTION 1. Permission and authority are hereby given and granted to HINES/McCAFFERY CONDO MANAGER LLC, upon the terms and subject to the conditions of this ordinance to construct, install, maintain and use two (2) Light Pole(s) on the public right-of-way adjacent to its premises known as 2350 N. Orchard St..

Said Light Pole(s) at N Orchard St measure(s):

Two (2) at one point one seven (1.17) foot in length, and nine point nine two (9.92) feet in width for a total of twenty-three point two one (23.21) square feet.

The location of said privilege shall be as shown on prints kept on file with the Department of Business Affairs and Consumer Protection and the Office of the City Clerk.

Said privilege shall be constructed in accordance with plans and specifications approved by the Department of Streets and Sanitation (Bureau of Electricity) and Department of Transportation (Division of Project Development).

This grant of privilege in the public way shall be subject to the provisions of Section 10-28-015 and all other required provisions of the Municipal Code of Chicago.

The grantee shall pay to the City of Chicago as compensation for the privilege #1141011 herein granted the sum of one hundred fifty (\$150.00) per annum in advance.

A 25% penalty will be added for payments received after due date.

The permit holder agrees to hold the City of Chicago harmless for any damage, relocation or replacement costs associated with damage, relocation or removal of private property caused by the City performing work in the public way.

Authority herein given and granted for a period of five (5) years from and after Date of Passage.

Alderman

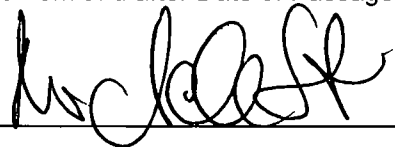

Michele Smith 43rd Ward

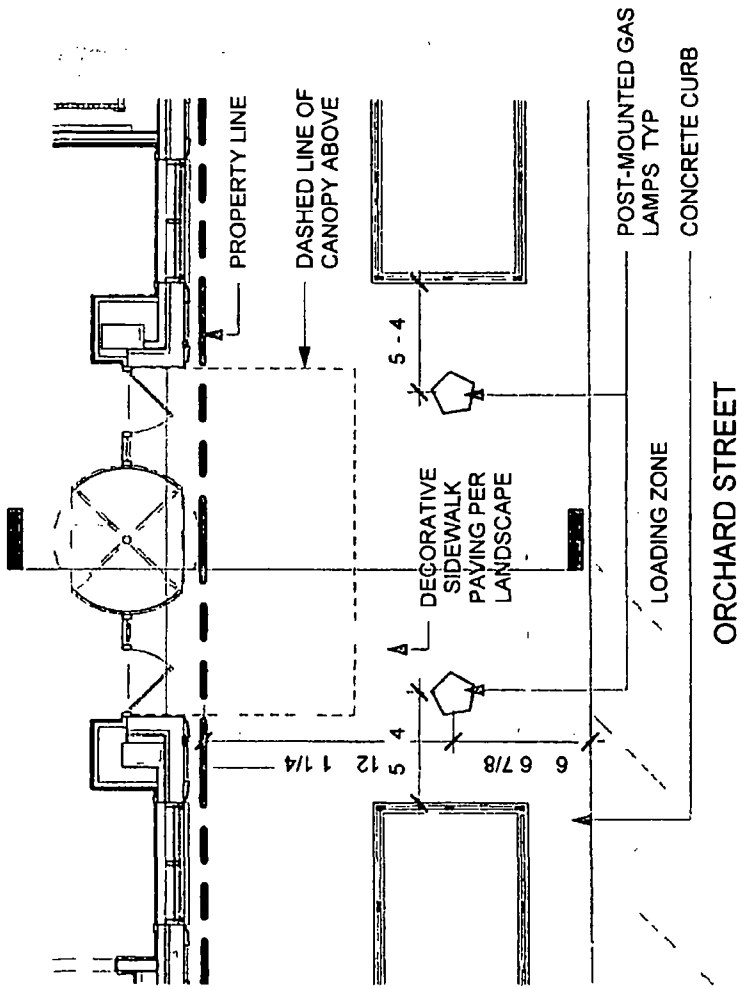
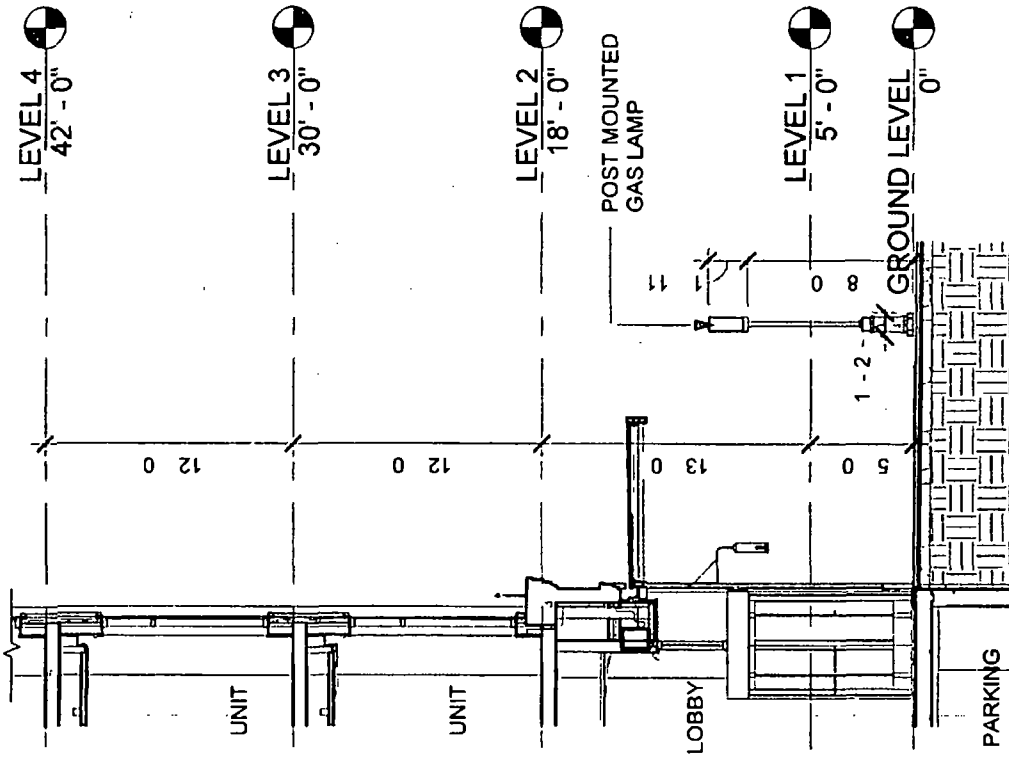

PUBLIC WAY USE - POST MOUNTED LAMPS

05/29/19

THE ORCHARD

2350 N ORCHARD STREET CHICAGO ILLINOIS

ANTUNOVICH ASSOCIATES ARCHITECT | 1144 3RD STREET NE WASHINGTON DC 20002 | PHONE 202 540 1144