



City of Chicago



O2021-5446

Office of the City Clerk

Document Tracking Sheet

Meeting Date:	12/15/2021
Sponsor(s):	Waguespack (32)
Type:	Ordinance
Title:	Grant(s) of privilege in public way for @ Properties
Committee(s) Assignment:	Committee on Transportation and Public Way

ORDINANCE

@ PROPERTIES

Acct. No.: 254488 - 18

Permit No: BACP1612963

Be It Ordained by the City Council of the City of Chicago:

SECTION 1. Permission and authority are hereby given and granted to @ PROPERTIES upon the terms and subject to the conditions of this ordinance to construct, install, maintain and use four (4) Light Fixture(s) projecting over the public right-of-way adjacent to its premises known as 2207 W ROSCOE ST.

Said Light Fixture(s) at W Roscoe St measure(s):

Four (4) at one point nine one (1.91) feet in length, one point nine one (1.91) feet in width and thirteen (13) feet above grade level.

The location of said privilege shall be as shown on prints kept on file with the Department of Business Affairs and Consumer Protection and the Office of the City Clerk.

Said privilege shall be constructed in accordance with plans and specifications approved by the Department of Transportation (Division of Project Development).

This grant of privilege in the public way shall be subject to the provisions of Section 10-28-015 and all other required provisions of the Municipal Code of Chicago.

The grantee shall pay to the City of Chicago as compensation for the privilege #BACP1612963 herein granted the sum of ninety (\$90.00) per annum in advance.

A 25% penalty will be added for payments received after due date.

The permit holder agrees to hold the City of Chicago harmless for any damage, relocation or replacement costs associated with damage, relocation or removal of private property caused by the City performing work in the public way.

Authority herein given and granted for a period of five (5) years from and after 09/08/2021.

Alderman:



Scott Waguespack / 32nd Ward

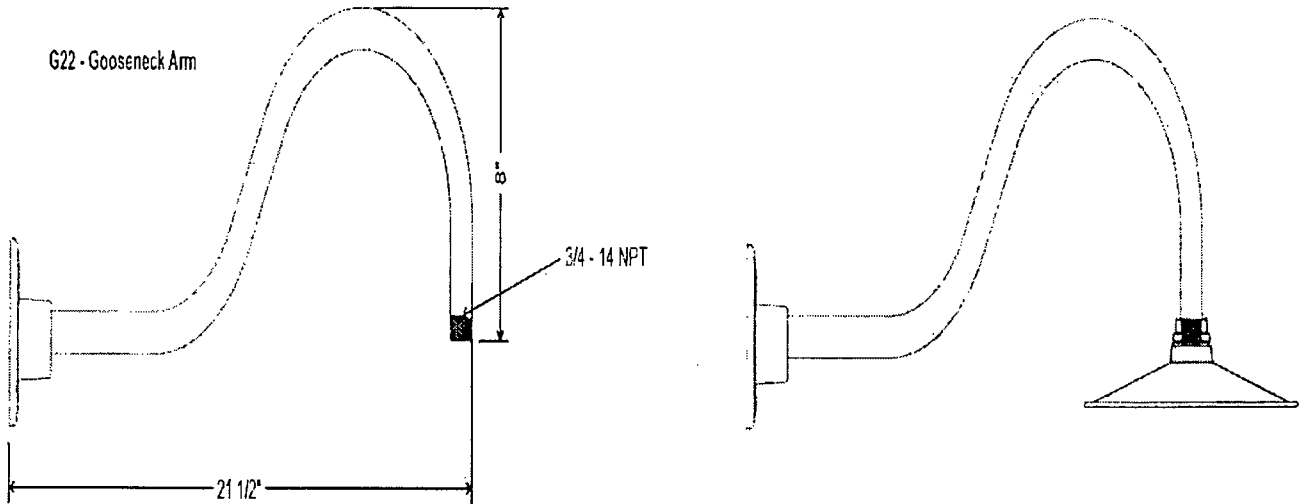

FCC10 - Conoco Series Shade

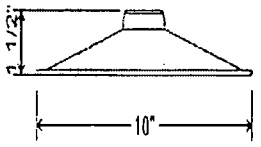

Gooseneck Lights

Scale: 3" = 1'-0"

Qty: 4

Barnlight Electric Company

OPTICNS: SHADE SIZE: 10" SHADE , FINISHES [POWDERCOAT & NATURAL]; 100-BLACK . GOOSENECK ARMS: G22 GOOSENECK ARM , GOOSENECK ARM FINISH [POWDERCOAT & NATURAL]; SAME AS SHADE . DUSK-TO-DAWN PHOTOCELL [GOOSENECK]; DUSK-TO-DAWN PHOTOCELL. COPPER/BRASS BACKING PLATE & HEX COVER: NONE , SOCKET TYPE [GU24] STANDARD MEDIUM BASE E26 SOCKET , EDISON LIGHT BULBS: NONE



PROPOSED



<p>DATE: 12/15/11</p>	<p>BY: [Signature]</p>	<p>NO: 1234</p>	<p>PROJECT: [Blank]</p>
<p>[Blank]</p>	<p>[Blank]</p>	<p>[Blank]</p>	<p>[Blank]</p>

© 2011 SWS SIGNS & GRAPHICS
 ALL RIGHTS RESERVED
 SWS SIGNS & GRAPHICS
 1234567890





Department of Business Affairs and Consumer Protection
Small Business Center - Public Way Use Unit
City Hall - 121 N. LaSalle Street, Room 800, Chicago, IL 60602
312-74-GOBIZ / 312-744-6249 • (312) 744-1944 (TTY)
<http://www.cityofchicago.org/bacp>

12/15/2021

Alderman Scott Waguespack
Ward # 32
City of Chicago
City Hall, Room 800
121 N. LaSalle Street
Chicago, IL 60602

Re: An ordinance to use and maintain a portion of the public right-of-way for **4 Light Fixture(s)** for **@ PROPERTIES**, adjacent to the premises known as **2207 W ROSCOE ST.**

Dear Alderman **Scott Waguespack**:

The applicant referenced above has requested the use of the public right-of-way for **Light Fixture(s)**. An ordinance has been prepared by the Department of Business Affairs and Consumer Protection - Small Business Center - Public Way Use Unit for presentation to the City Council. Because this request was made for properties located in your ward, as approved by you as per the attached, I respectfully request that you introduce the attached ordinance at the next City Council meeting.

If you have any questions regarding this ordinance, please contact Jaime Viramontes at (312) 744-8068.

Department of Business Affairs and Consumer Protection