



City of Chicago



O2021-2713

Office of the City Clerk

Document Tracking Sheet

Meeting Date:	6/25/2021
Sponsor(s):	Tunney (44)
Type:	Ordinance
Title:	Grant(s) of privilege in public way for Belmont Development LLC
Committee(s) Assignment:	Committee on Transportation and Public Way

ORDINANCE

Belmont Development, LLC

Acct. No.: 475352 - 1

Permit No. BACP1528583

Be It Ordained by the City Council of the City of Chicago

SECTION 1. Permission and authority are hereby given and granted to Belmont Development, LLC upon the terms and subject to the conditions of this ordinance to construct, install, maintain and use two (2) Foundation Wall(s) under the public right-of-way adjacent to its premises known as W BELMONT AVE.

Said Foundation Wall(s) at W Belmont Ave measure(s):

One (1) at thirty-three point zero eight (33.08) feet in length and seventy-five (75) feet in width for a total of two thousand four hundred eighty-one (2,481) square feet.

Said Foundation Wall(s) at Alley Between W Belmont Ave & W Melrose Ave measure(s)

One (1) at forty-four point four two (44.42) feet in length and five (5) feet in width for a total of two hundred twenty-two point one (222.1) square feet.

The location of said privilege shall be as shown on prints kept on file with the Department of Business Affairs and Consumer Protection and the Office of the City Clerk.

Said privilege shall be constructed in accordance with plans and specifications approved by the Department of Transportation (Office of Underground Coordination) and Department of Planning and Development.

This grant of privilege in the public way shall be subject to the provisions of Section 10-28-015 and all other required provisions of the Municipal Code of Chicago.

The grantee shall pay to the City of Chicago as compensation for the privilege #BACP1528583 herein granted the sum of one thousand sixteen (\$1,016.00) per annum in advance.

A 25% penalty will be added for payments received after due date.

The permit holder agrees to hold the City of Chicago harmless for any damage, relocation or replacement costs associated with damage, relocation or removal of private property caused by the City performing work in the public way

Authority herein given and granted for a period of five (5) years from and after Date of Passage.

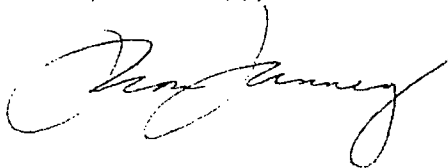

Alderman:

Thomas Tunney 44th Ward

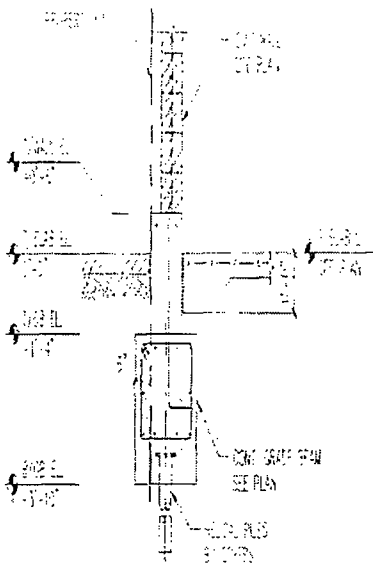

① SECTION AT BACK WALL

SCALE 1/8" = 1'-0"

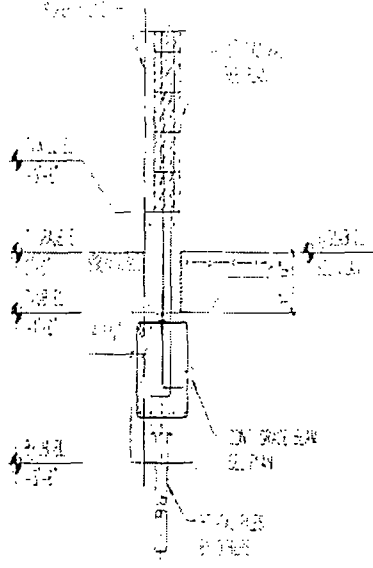

① TYP. SECTION AT FRONT WALL

SCALE 1/8" = 1'-0"

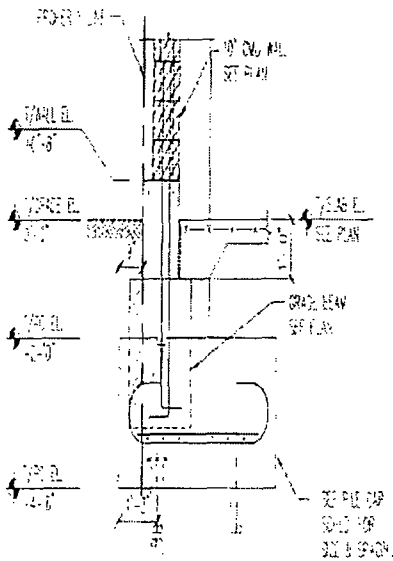

② PILE CAP AT FRONT WALL

SCALE 1/8" = 1'-0"

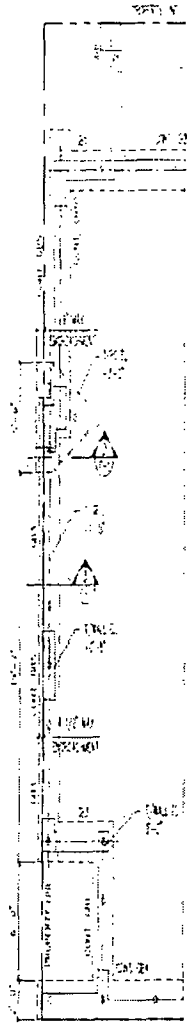
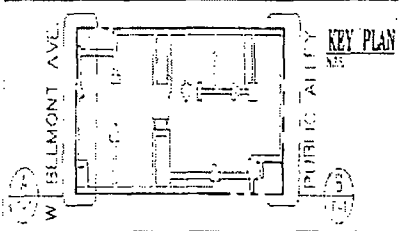

PARTIAL FOUND. PLAN - A
SCALE 1/8" = 1'-0"

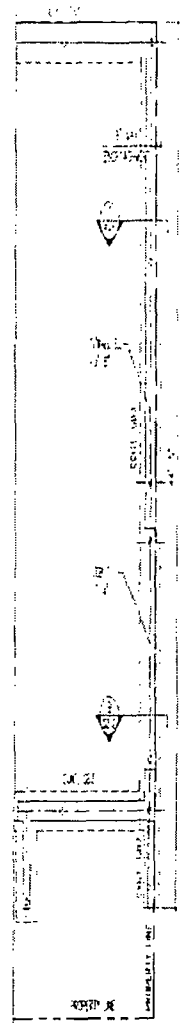

PARTIAL FOUND. PLAN - B
SCALE 1/8" = 1'-0"



Alex. Pollack

DESIGNED BY: ALEXANDER POLLACK
 DRAWN BY: [unclear]
 CHECKED BY: [unclear]
 APPROVED BY: [unclear]

Apartment Building
 1218 W. Belmont Ave.
 Chicago, Illinois

ISSUE: [unclear] DATE: [unclear]
 REVISIONS: [unclear]
 SCALE: [unclear]

F-1

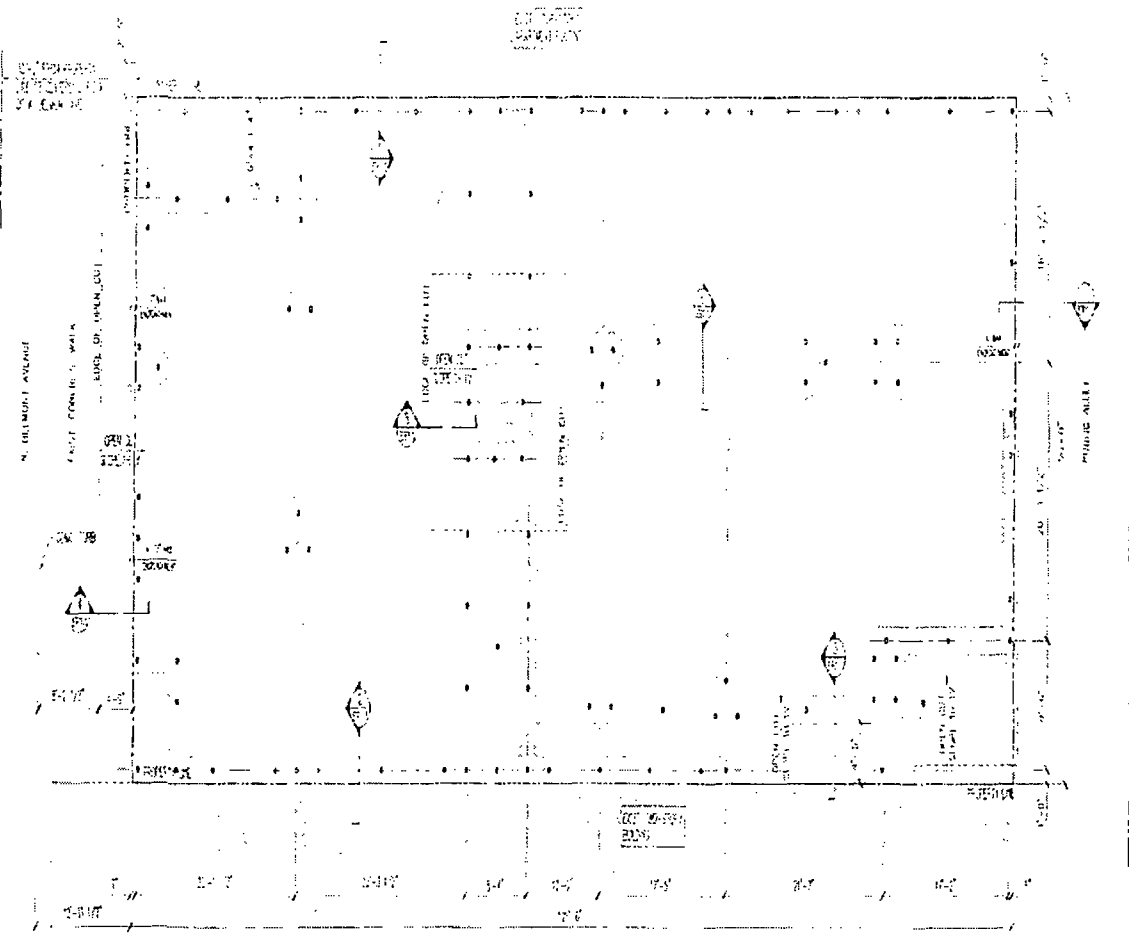

SEE PLAN FOR
 ALL DIMENSIONS
 AND ELEVATIONS

EARTH RETENTION PLAN
 AND SPECIFICATIONS

REFERENCE ELEVATION
 G.C. = 100' C.T.D.

GENERAL NOTES

1. CONTRACTOR SHALL BE RESPONSIBLE FOR OBTAINING ALL NECESSARY PERMITS AND APPROVALS FROM ALL AGENCIES.
2. EXISTING UTILITIES SHALL BE PROTECTED AND MAINTAINED AT ALL TIMES. CONTRACTOR SHALL BE RESPONSIBLE FOR OBTAINING ALL NECESSARY PERMITS AND APPROVALS FROM ALL AGENCIES.
3. CONTRACTOR SHALL BE RESPONSIBLE FOR OBTAINING ALL NECESSARY PERMITS AND APPROVALS FROM ALL AGENCIES.
4. CONTRACTOR SHALL BE RESPONSIBLE FOR OBTAINING ALL NECESSARY PERMITS AND APPROVALS FROM ALL AGENCIES.
5. CONTRACTOR SHALL BE RESPONSIBLE FOR OBTAINING ALL NECESSARY PERMITS AND APPROVALS FROM ALL AGENCIES.
6. CONTRACTOR SHALL BE RESPONSIBLE FOR OBTAINING ALL NECESSARY PERMITS AND APPROVALS FROM ALL AGENCIES.
7. CONTRACTOR SHALL BE RESPONSIBLE FOR OBTAINING ALL NECESSARY PERMITS AND APPROVALS FROM ALL AGENCIES.



AP
 PROFESSIONAL ENGINEER
 LICENSE NO. 12345

AP
 PROFESSIONAL ENGINEER
 LICENSE NO. 12345

AP
 PROFESSIONAL ENGINEER
 LICENSE NO. 12345

AP
 PROFESSIONAL ENGINEER
 LICENSE NO. 12345

AP
 PROFESSIONAL ENGINEER
 LICENSE NO. 12345



AP
 ARCHITECT
 LICENSE NO. 12345

AP
 ARCHITECT
 LICENSE NO. 12345

AP
 ARCHITECT
 LICENSE NO. 12345

AP
 ARCHITECT
 LICENSE NO. 12345

ER1.0

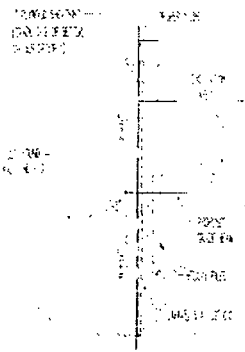

1 TYP. SECTION AT WEST WALL
SCALE 1/4" = 1'-0"

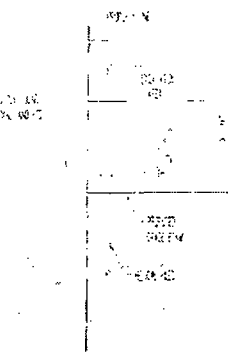

2 SECTION AT EAST WALL
SCALE 1/4" = 1'-0"



3 SECTION AT EAST WALL
SCALE 1/4" = 1'-0"



4 SECTION AT SOUTH WALL
SCALE 1/4" = 1'-0"

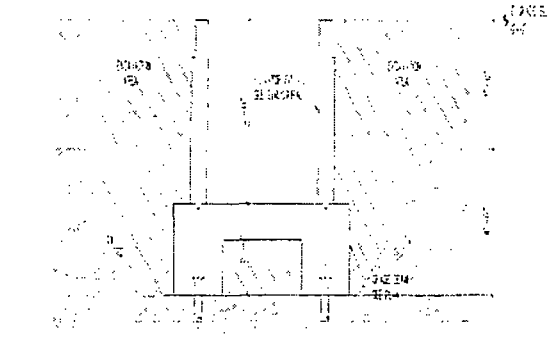

5 SECTION AT ELEVATOR PIT
SCALE 1/4" = 1'-0"

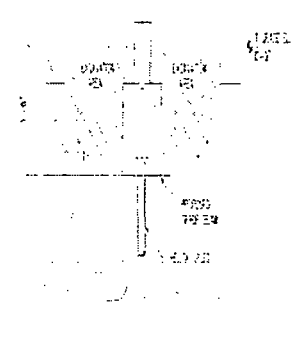

6 TYP. SECTION AT GRADE BEAM
SCALE 1/4" = 1'-0"

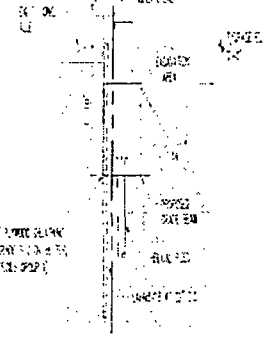

7 TYP. SECTION AT NORTH WALL
SCALE 1/4" = 1'-0"

REFERENCE SECTION
1'-0" = 3.00 C.L.D.



AP
REGISTERED PROFESSIONAL ENGINEER
STATE OF CALIFORNIA
NO. 12345
EXPIRES 12/31/2024

NO.	DATE	REVISION
1		
2		
3		
4		
5		



PROJECT
BUILDING
NO. 12345
DATE
12/31/2024

ER1.1



Department of Business Affairs and Consumer Protection
Small Business Center - Public Way Use Unit
City Hall - 121 N. LaSalle Street, Room 800, Chicago, IL 60602
312-74-GOBIZ / 312-744-6249 • (312) 744-1944 (TTY)
<http://www.cityofchicago.org/baco>

06/23/2021

Alderman Thomas Tunney
Ward # 44
City of Chicago
City Hall, Room 800
121 N. LaSalle Street
Chicago, IL 60602

Re. An ordinance to use and maintain a portion of the public right-of-way for **2 Foundation Wall(s)** for **Belmont Development, LLC**, adjacent to the premises known as - **W BELMONT AVE.**

Dear Alderman **Thomas Tunney**:

The applicant referenced above has requested the use of the public right-of-way for **Foundation Wall(s)**. An ordinance has been prepared by the Department of Business Affairs and Consumer Protection - Small Business Center - Public Way Use Unit for presentation to the City Council. Because this request was made for properties located in your ward, as approved by you as per the attached, I respectfully request that you introduce the attached ordinance at the next City Council meeting.

If you have any questions regarding this ordinance, please contact Anthony Bertuca at (312) 744-5506

Department of Business Affairs and Consumer Protection