



City of Chicago



O2017-6667

Office of the City Clerk
Document Tracking Sheet

Meeting Date:	9/6/2017
Sponsor(s):	Waguespack (32)
Type:	Ordinance
Title:	Grant(s) of privilege in public way for FJallRaven
Committee(s) Assignment:	Committee on Transportation and Public Way

ORDINANCE
FJALLRAVEN
Acct. No. 395777 - 1
Permit No. 1129159

Be It Ordained by the City Council of the City of Chicago:

SECTION 1. Permission and authority are hereby given and granted to FJALLRAVEN, upon the terms and subject to the conditions of this ordinance to maintain and use one (1) sign(s) projecting over the public right-of-way attached to its premises known as 1708 N. Damen Ave..

Said sign structure(s) measures as follows; along N Damen Ave:

One (1) at two point five (2.5) feet in length, one point eight three (1.83) feet in height and eight point five (8.5) feet above grade level.

The location of said privilege shall be as shown on prints kept on file with the Department of Business Affairs and Consumer Protection and the Office of the City Clerk.

Said privilege shall be constructed in accordance with plans and specifications approved by the Department of Transportation (Division of Project Development) and Zoning Department - Signs.

This grant of privilege in the public way shall be subject to the provisions of Section 10-28-015 and all other required provisions of the Municipal Code of Chicago.

The grantee shall pay to the City of Chicago as compensation for the privilege #1129159 herein granted the sum of one hundred (\$100.00) per annum in advance.

A 25% penalty will be added for payments received after due date.

The permit holder agrees to hold the City of Chicago harmless for any damage, relocation or replacement costs associated with damage, relocation or removal of private property caused by the City performing work in the public way.

Authority herein given and granted for a period of five (5) years from and after Date of Passage.

Alderman 
Scott Waguespack 32nd Ward

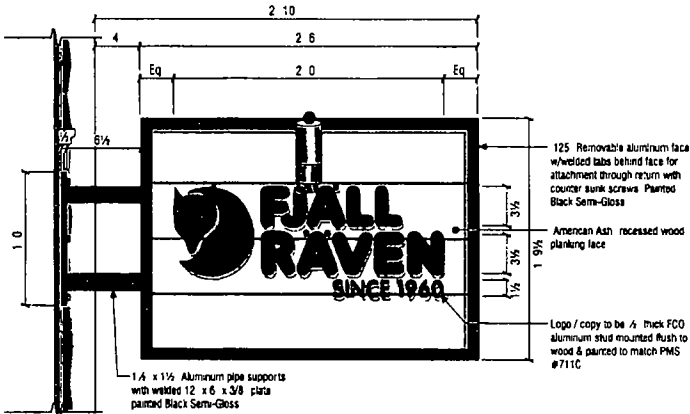

A SIGN ELEVATION/ CUSTOM FABRICATED PROJECTING BLADE SIGN
 Qty One (1) Sign Required Scale 1/4" = 1' 0"

SPECIFICATIONS

- FACES** 125 ALUMINUM FACES PAINTED BLACK SEMI-GLOSS W/1 DEEP RECESSED FACE FOR 13/16 THICK AMERICAN ASH WOOD PLANKING
- LOGO/COPY** 1/4 THICK FLUSH STUD MOUNTED FCO WATER JET CUT ALUMINUM LOGO & LETTERS PAINTED TO MATCH PMS #711C RED
- RETURNS** 3 DEEP 125 ALUMINUM RETURNS PAINTED BLACK SEMI GLOSS
- SUPPORTS** 1 1/4 x 1 1/2 x 1/8 ALUMINUM PIPE SUPPORTS W/WELDED 4 x 4 x 3/8 THICK ALUMINUM MOUNTING PLATES SIGN ATTACHED W/3/8 DIA LAG BOLT FASTENERS ALL PAINTED BLACK SEMI GLOSS
- ILLUMINATION** DOWN LIGHTING PROVIDED BY BLACK LED BULLET LIGHT FIXTURES & SUPPORTED W/1/4 DIA ALUMINUM ROUND PIPE PAINTED BLACK
- NOTE** FIELD VERIFY ALL MEASUREMENTS AND CONDITIONS PRIOR TO MANUFACTURING

Note to All Contractors

120 sign Voltage
 This sign is to be installed in accordance with the requirements of Article 680 of the National Electrical Code or other applicable local codes. This includes proper grounding and bonding of the sign. All work procedures to be installed with UL Listed aluminum signs.

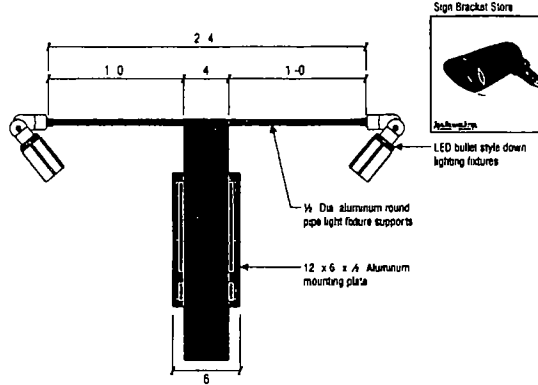

1 SIDE VIEW
 Scale 1/4" = 1' 0"

superior
 ELECTRICAL SERVICES
 1700 West Argonne Street
 Laing Beach, California 94933-3494
 Phone: 562.495.3888
 Facsimile: 562.435.1867
 www.superiorelectrical.com

Project: Fall Raven
 Address: 1708 N Damen Ave Chicago, IL 60647
 Account Manager: Scott Demerjian
 Designer: A. F. Pagan, Inc. 1.50
 Scale: AS NOTED
 Design No: 17-04 3183-02
 Date: 04-28-17
 Reg No:
 Revisions: R1: AD (3) 04/28/17 Revised to add to construction detail
 R2: AD (1) 04/28/17 Rev. FCO added to A elev. 1 w/ 1/4" aluminum face



APPROVALS

FOR JOB CHECK	DATE
Acc: Mgr	
FOR CONSTRUCTION	DATE
Acc: Mgr	
FOR INSTALL ONLY	DATE
Acc: Mgr	

Page 3 of 4
 This is a copyrighted drawing created by Superior Electrical Services, Inc. It is intended for your project only. It is not to be used for any other project without the written consent of Superior Electrical Services, Inc. The company of origin, name, location or description of the project shall not be used in any way without the written consent of Superior Electrical Services, Inc. All designs are the property of Superior Electrical Services, Inc. © SEA 2017
 Note: No other drawings have been prepared. All other drawings are void.



09/06/2017

Alderman **Scott Waguespack**
Ward # **32**
City of Chicago
City Hall, Room **300**
121 North LaSalle Street
Chicago, Illinois 60602

Re: An ordinance to use and maintain a portion of the public right-of-way for **one (1) sign(s)** for **FJALLRAVEN**, adjacent to the premises known as **1708 N. Damen Ave.**.

Dear Alderman **Scott Waguespack**:

The applicant referenced above has requested the use of the public right-of-way for a **sign(s)**. An ordinance has been prepared by the Department of Business Affairs and Consumer Protection – Small Business Center - Public Way Use Unit for presentation to the City Council. Because this request was made for properties located in your ward, as approved by you as per the attached, I respectfully request that you introduce the attached ordinance at the next City Council meeting.

If you have any questions regarding this ordinance, please contact Anthony Bertuca at (312) 744-5506.

Department of Business Affairs and Consumer Protection