



# City of Chicago



O2015-733

Office of the City Clerk

## Document Tracking Sheet

<b>Meeting Date:</b>	1/21/2015
<b>Sponsor(s):</b>	Ervin (28)
<b>Type:</b>	Ordinance
<b>Title:</b>	Grant(s) of privilege in public way for Dream, Inc. - sign
<b>Committee(s) Assignment:</b>	Committee on Transportation and Public Way

ORDINANCE  
DREAM INC  
Acct. No. 40689 - 2  
Permit No. 1115856

*Be It Ordained by the City Council of the City of Chicago:*

SECTION 1. Permission and authority are hereby given and granted to DREAM INC, upon the terms and subject to the conditions of this ordinance to maintain and use one (1) sign(s) projecting over the public right-of-way attached to its premises known as 4042 W. Madison St..

Said sign structure(s) measures as follows; along W. Madison Street:  
One (1) at twenty (20) feet in length, four (4) feet in height and thirteen (13) feet above grade level.

The location of said privilege shall be as shown on prints kept on file with the Department of Business Affairs and Consumer Protection and the Office of the City Clerk.

Said privilege shall be constructed in accordance with plans and specifications approved by the Department of Transportation (Division of Project Development) and Zoning Department - Signs.

This grant of privilege in the public way shall be subject to the provisions of Section 10-28-015 and all other required provisions of the Municipal Code of Chicago.

The grantee shall pay to the City of Chicago as compensation for the privilege #1115856 herein granted the sum of three hundred (\$300.00) per annum in advance.

A 25% penalty will be added for payments received after due date.

The permit holder agrees to hold the City of Chicago harmless for any damage, relocation or replacement costs associated with damage, relocation or removal of private property caused by the City performing work in the public way.

Authority herein given and granted for a period of five (5) years from and after Date of Passage.

Alderman   
Jason Ervin 28<sup>th</sup> Ward

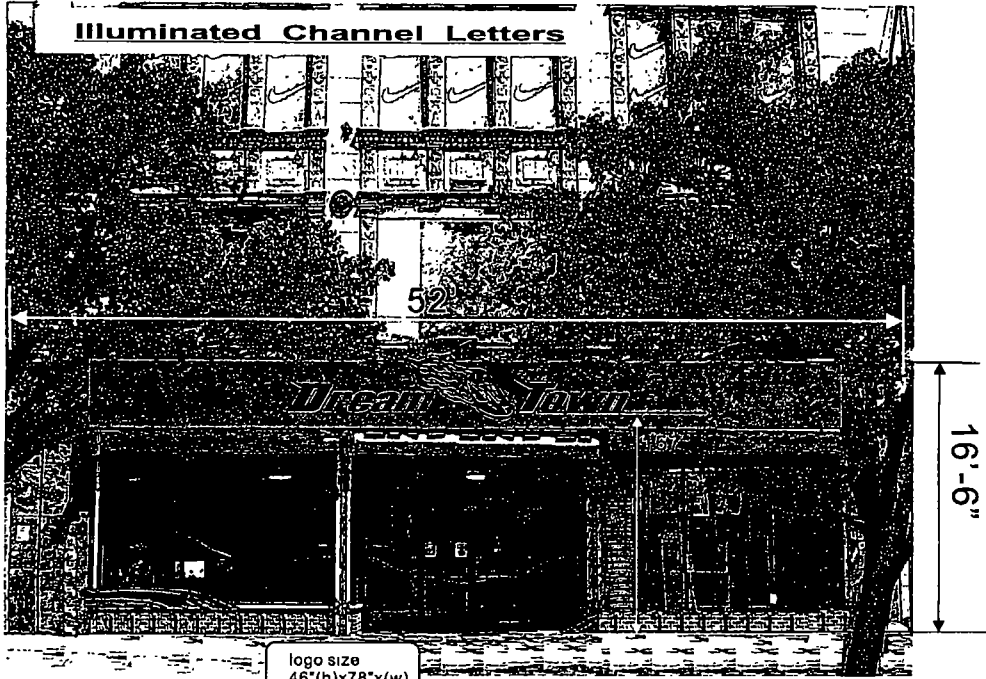

logo size  
46"(h)x78"x(w)

**LED Channel Letter Side View**

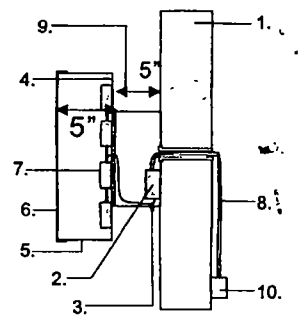

1. Building facade / Sign band
2. LED Transformer (UL)  
Input 120VAC, Output 12VDC/5A
3. Disconnect Safety Switch
4. 0.040 Aluminum back
5. 0.040 Aluminum return
6. Acrylic face
7. LED lamp
8. 12G Electric wire with flexible conduit
9. Raceway (color matches w/wall color)
10. Power connection box

**Detail of Sign**

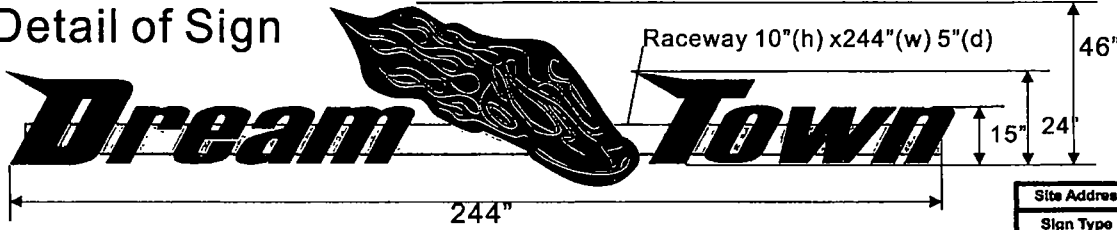

SIGNATURE \_\_\_\_\_  
 LANDLORD \_\_\_\_\_  
 TENANT \_\_\_\_\_

TOTAL SIGN AREA: 46"(H) X 244"(W) = 77.94 SQF

Site Address	4042 W. Madison st.			
Sign Type	Illuminated Channel Letters			
Physical Information	FACE	RETURN	TRIM	LIGHT
	black & red	bronze	black	LED

All sign designs and concepts shown here are confidential and are the property of Cosmos Sign Co. They are not to be distributed, exhibited, copied, or otherwise used without our written permission.  
**COMPUTER GENERATED COLORS ARE NOT A TRUE MATCH TO ANY PMS, VINYL, OR PAINT.**

Client: Dream town	Drawing #:
Approved:	Date:
Scale: 1"= 96"	Rev Date:
Drawn by:	