



City of Chicago



SO2018-7794

Office of the City Clerk

Document Tracking Sheet

Meeting Date: 9/20/2018

Sponsor(s): Emanuel (Mayor)

Type: Ordinance

Title: 500 N Dearborn Firehouse Redevelopment agreement and sale/transfer of City parcels at 55 W Illinois St and 444 N Dearborn St to EC 42 Developer LLC for development and construction of new firehouse, Fire Prevention Bureau and construction of private offices

Committee(s) Assignment: Committee on Housing and Real Estate

SUBSTITUTE ORDINANCE

WHEREAS, the City of Chicago (the "City") is a municipal corporation and home rule unit of government under Article VII, Section 6(a) of the 1970 Constitution of the State of Illinois, and, as such, may exercise any power and perform any function pertaining to its government and affairs; and

WHEREAS, the City has the authority to promote the health, safety and welfare of its inhabitants, and to enter into contractual agreements to achieve these important purposes; and

WHEREAS, the intergovernmental provisions of Article VII, Section 10 of the 1970 Constitution of the State of Illinois authorizes the City to contract and otherwise associate with individuals, associations, and corporations in any manner not prohibited by law; and

WHEREAS, the City is authorized to convey or exchange interests in real property owned by the City with private parties pursuant to its powers as a home rule unit of government, upon making the requisite findings and approval by the City Council; and

WHEREAS, within the City of Chicago is a block bounded by Hubbard, Dearborn, Illinois and Clark Streets (the "Development Block"); and

WHEREAS, within the Development Block the City owns (i) an approximately 28,323 square foot property commonly known as 55 West Illinois Street and 444 North Dearborn Street (collectively, the "Existing Firehouse Parcel"), which is legally described in Exhibit A attached hereto, and (ii) a north-south alley (the "Existing Alley Parcel"), which is legally described in Exhibit B attached hereto (collectively, the "Existing City Property"); and

WHEREAS, located on the Existing Firehouse Parcel is the Chicago Fire Department's District One Headquarters and Firehouse as well as the Chicago Fire Department Fire Prevention Bureau (collectively, "Existing FD Facilities"); and

WHEREAS, EC 42 Developer LLC, an Illinois limited liability company (the "Developer"), by and through its affiliated companies, owns and controls all portions of the Development Block other than the Existing City Property (collectively, the "Developer's Parcel"); and

WHEREAS, recognizing the potential public benefits of Developer's unique ownership of the Developer's Parcel and Developer's desire to redevelop a portion of the Development Block, the City is prepared to convey a portion of the Existing City Property, including certain air rights above that part of the Existing City Property not being conveyed to Developer (the "New Firehouse Parcel"), in exchange for (i) monetary payments to the City, and (ii) the construction on the New Firehouse Parcel by Developer for the City of a new, state-of-the-art, environmentally and energy efficient firehouse with expanded space for the City's Fire Prevention Bureau, including all furniture, fixtures, and other related equipment for the firehouse and the City's Fire Prevention Bureau (collectively, the "New Firehouse"); and

WHEREAS, on April 28, 2017, the City and the Developer entered into a non-binding Memorandum of Understanding (the "MOU") to establish the framework for a public-private project providing for the Developer's development and construction within the Development Block of (i) the New Firehouse, and (ii) a new, private office use development (the "New Development") pursuant to the Municipal Code and contingent upon receipt of all applicable permits and City zoning approvals (collectively, the "Project"); and

WHEREAS, the real property that the City will convey to the Developer will be (i) an approximately 14,654 square foot portion of the Existing Firehouse Parcel, and (ii) an approximately 3,153 square foot portion of the Existing Alley Parcel, which are collectively depicted in Exhibit C attached hereto (the "Transfer City Property"), along with certain air rights above the New Firehouse Parcel and certain subsurfaces below grade level of the New Development for subsurface parking and caissons necessary for the New Development (collectively, the "Acquisition Property"); and

WHEREAS, the MOU called upon the City and the Developer to undertake preliminary discussions and due diligence with regard to the Project and the Existing City Property and attempt to negotiate a redevelopment agreement to provide for the Project; and

WHEREAS, the Developer has now filed its application for planned development approval and other required zoning relief for the Project and the City and Developer have completed negotiations on the "Dearborn Firehouse Redevelopment Agreement" attached hereto as Exhibit D (the "Redevelopment Agreement"); and

WHEREAS, as provided in the Redevelopment Agreement, the Developer will be responsible for all costs for the construction of the New Firehouse, which shall not exceed a budget determined by the City as set forth in the Redevelopment Agreement and estimated to be \$20 million (the "Firehouse Budget") and will also include demolition of existing structures, construction of permanent parking, and relocation costs for the existing firehouse facilities and operations; and

WHEREAS, the Developer will be responsible for any cash payments required for floor area bonuses under the proposed Planned Development and any cash payment required by the Affordable Requirements Ordinance; and

WHEREAS, as a condition of any title conveyance of City property, the issuance of a building permit, or the commencement of construction of the New Firehouse, the Developer will make a cash payment of \$5,000,000 to the City; and

WHEREAS, the City Council, after due and careful consideration, has concluded that the redevelopment and use of the Development Block for the Project and specifically for the construction of the New Firehouse pursuant to and in accordance with this Ordinance and the Redevelopment Agreement will serve and be in the best interests of the City; and

WHEREAS, public notices advertising the Department's intent to enter into a negotiated redevelopment agreement for the conveyance of the Transfer City Property and requesting alternative proposals appeared in the *Chicago Sun-Times* on May 1, May 8, and May 15, 2017; and

WHEREAS, no other responsive proposals were received by the deadline indicated in the aforesaid notices; *now, therefore*,

BE IT ORDAINED BY THE CITY COUNCIL OF THE CITY OF CHICAGO:

SECTION 1. The foregoing recitals are hereby adopted as the findings of the City Council.

SECTION 2. The conveyance of the Acquisition Property, including the Transfer City Property, to the Developer is hereby approved. This approval is expressly conditioned upon the City entering into the Redevelopment Agreement with the Developer and the terms and conditions set forth therein with regard to any and all conveyances of City property. The Commissioner of the Department of Planning and Development (the "Commissioner") or a designee of the Commissioner is each hereby authorized, with the approval of the City's Corporation Counsel, to negotiate, execute and deliver the Redevelopment Agreement, and such other supporting documents and agreements as may be necessary or appropriate to carry out and comply with the provisions of the Redevelopment Agreement, including without limitation, a ground lease and a declaration of covenants, conditions, restrictions and reciprocal easements required by the Redevelopment Agreement, all with such changes, deletions and insertions as shall be approved by the persons executing the Redevelopment Agreement and such other supporting documents.

SECTION 3. The Mayor or the Mayor's proxy is each hereby authorized to execute, and the City Clerk or the Deputy City Clerk is each hereby authorized to attest, a quitclaim deed or quitclaim deeds conveying the Acquisition Property, including the Transfer City Property, to the Developer, or to a land trust of which the Developer is the sole beneficiary, or to an entity of which the Developer is the sole controlling party or which is comprised of the same principal parties, subject to those covenants, conditions and restrictions set forth in the Redevelopment Agreement.

SECTION 4. If any provision of this ordinance shall be held to be invalid or unenforceable for any reason, the invalidity or unenforceability of such provision shall not affect any of the other provisions of this ordinance.

SECTION 5. All ordinances, resolutions, motions or orders in conflict with this ordinance are hereby repealed to the extent of such conflict.

SECTION 6. This ordinance shall take effect immediately upon its passage and approval.

Attachments:

- Exhibit A – Legal Description of Existing Firehouse Parcel**
- Exhibit B – Legal Description of Existing Alley Parcel**
- Exhibit C – Depiction of Transfer City Property**
- Exhibit D – Redevelopment Agreement**

EXHIBIT A

EXISTING FIREHOUSE PARCEL

EXCEPT THE SOUTH 99 FEET OF THE FOLLOWING DESCRIBED PROPERTY TAKEN AS A TRACT: LOTS 11 TO 25 AND LOTS 10 AND 26 EXCEPT THE WEST 8 FEET THEREOF, TOGETHER WITH THE 100 FOOT STRIP OF LAND LYING WEST OF AND ADJOINING LOTS 14 TO 22 INCLUSIVE AND EAST OF AND ADJOINING LOTS 13 AND 23, ALSO THE EAST-WEST STRIP OF LAND LYING SOUTH OF AND ADJOINING LOTS 10 TO 13 INCLUSIVE AND NORTH OF AND ADJOINING LOTS 23 TO 26 INCLUSIVE EXCEPT THE WEST 8 FEET THEREOF, AS VACATED BY CITY ORDINANCE PASSED SEPTEMBER 26, 1872 ALL IN BLOCK 7 OF JOHN S. BUSSING'S SUBDIVISION OF BLOCKS 7 AND 10 IN WOLCOTT'S ADDITION TO CHICAGO IN THE EAST ½ OF THE NORTH EAST ¼ OF SECTION 9, TOWNSHIP 39 NORTH, RANGE 14 EAST OF THE THIRD PRINCIPAL MERIDIAN, IN COOK COUNTY, ILLINOIS.

EXHIBIT B

EXISTING ALLEY PARCEL

THAT PART OF BLOCK 7 LYING EAST OF THE EAST LINE OF LOTS 1 THROUGH 9 IN JOHN S. PRUSSING'S SUBDIVISION EXCEPT THEREFROM THAT PART DESCRIBED AS FOLLOWS: THE SOUTH 99 FEET OF THAT PART OF LOTS 18 TO 25, LOT 26 (EXCEPT THE WEST 8 FEET THEREOF), TOGETHER WITH THE 10 FOOT STRIP OF LAND LYING WEST OF AND ADJOINING LOTS 18 TO 22, INCLUSIVE, AND EAST OF AND ADJOINING LOT 23 VACATED BY CITY ORDINANCE PASSED SEPTEMBER 26, 1872, ALL IN JOHN S. PRUSSING'S SUBDIVISION OF BLOCKS 7 AND 10 IN WOLCOTT'S ADDITION TO CHICAGO IN THE EAST HALF OF THE NORTHEAST QUARTER OF SECTION 9, TOWNSHIP 39 NORTH, RANGES 14, EAST OF THE THIRD PRINCIPAL MERIDIAN,

(EXCEPT THE FIRE STATION PARCEL DESCRIBED AS FOLLOWS:

THAT PART OF BLOCK 7 LYING EAST OF THE EAST LINE OF LOTS 1 THROUGH 9 IN SAID BLOCK 7, IN JOHN S. PRUSSING'S SUBDIVISION OF BLOCKS 7 AND 10 IN WOLCOTT'S ADDITION TO CHICAGO IN THE EAST HALF OF THE NORTHEAST QUARTER OF SECTION 9, TOWNSHIP 39 NORTH, RANGES 14, EAST OF THE THIRD PRINCIPAL MERIDIAN, LYING BELOW A HORIZONTAL PLANE HAVING AN ELEVATION OF +64.50 FEET CHICAGO CITY DATUM AND LYING ABOVE A HORIZONTAL PLANE HAVING AN ELEVATION OF +14.00 FEET CHICAGO CITY DATUM AND LYING WITHIN ITS HORIZONTAL BOUNDARY PROJECTED VERTICALLY AND DESCRIBED AS FOLLOWS:

COMMENCING AT THE NORTHWEST CORNER OF BLOCK 7 IN JOHN S. PRUSSING'S SUBDIVISION AFORESAID; THENCE SOUTH 90 DEGREES 00 MINUTES 00 SECONDS EAST ALONG THE NORTH LINE OF SAID BLOCK 7 A DISTANCE OF 109.85 FEET TO THE POINT OF BEGINNING; THENCE SOUTH 90 DEGREES 00 MINUTES 00 SECONDS EAST ALONG THE NORTH LINE OF SAID BLOCK 7 A DISTANCE OF 89.20 FEET; THENCE SOUTH 00 DEGREES 16 MINUTES 14 SECONDS EAST 125.00 FEET; THENCE NORTH 90 DEGREES 00 MINUTES 00 SECONDS WEST 89.10 FEET; THENCE NORTH 00 DEGREES 19 MINUTES 07 SECONDS WEST 125.00 FEET TO THE POINT OF BEGINNING;

TOGETHER WITH

THAT PART OF BLOCK 7 LYING EAST OF THE EAST LINE OF LOTS 1 THROUGH 9 IN SAID BLOCK 7, IN JOHN S. PRUSSING'S SUBDIVISION OF BLOCKS 7 AND 10 IN WOLCOTT'S ADDITION TO CHICAGO IN THE EAST HALF OF THE NORTHEAST QUARTER OF SECTION 9, TOWNSHIP 39 NORTH, RANGES 14, EAST OF THE THIRD PRINCIPAL MERIDIAN, LYING BELOW A HORIZONTAL PLANE HAVING AN ELEVATION OF +14.00 FEET CHICAGO CITY DATUM AND LYING WITHIN ITS HORIZONTAL BOUNDARY PROJECTED VERTICALLY AND DESCRIBED AS FOLLOWS:

COMMENCING AT THE NORTHWEST CORNER OF BLOCK 7 IN JOHN S. PRUSSING'S SUBDIVISION AFORESAID; THENCE SOUTH 90 DEGREES 00 MINUTES 00 SECONDS EAST ALONG THE NORTH LINE OF SAID BLOCK 7 A DISTANCE OF 106.57 FEET TO THE POINT OF BEGINNING; THENCE SOUTH 90 DEGREES 00 MINUTES 00 SECONDS EAST ALONG THE NORTH LINE OF SAID BLOCK 7 A DISTANCE OF 92.48 FEET; THENCE SOUTH 00 DEGREES 16 MINUTES 14 SECONDS EAST 125.00 FEET; THENCE

NORTH 90 DEGREES 00 MINUTES 00 SECONDS WEST 89.10 FEET; THENCE NORTH 00 DEGREES 19 MINUTES 07 SECONDS WEST 19.33 FEET; THENCE NORTH 90 DEGREES 00 MINUTES 00 SECONDS WEST 3.86 FEET; THENCE NORTH 00 DEGREES 00 MINUTES 00 SECONDS EAST 105.67 FEET TO THE POINT OF BEGINNING), ALL IN COOK COUNTY, ILLINOIS.

AREA AT ELEVATION +64.50 CCD = 28,323 SQ. FT. OR 0.65 ACRES MORE OR LESS.

EXHIBIT C

DEPICTION OF TRANSFER CITY PROPERTY

TRANSFER CITY PROPERTY

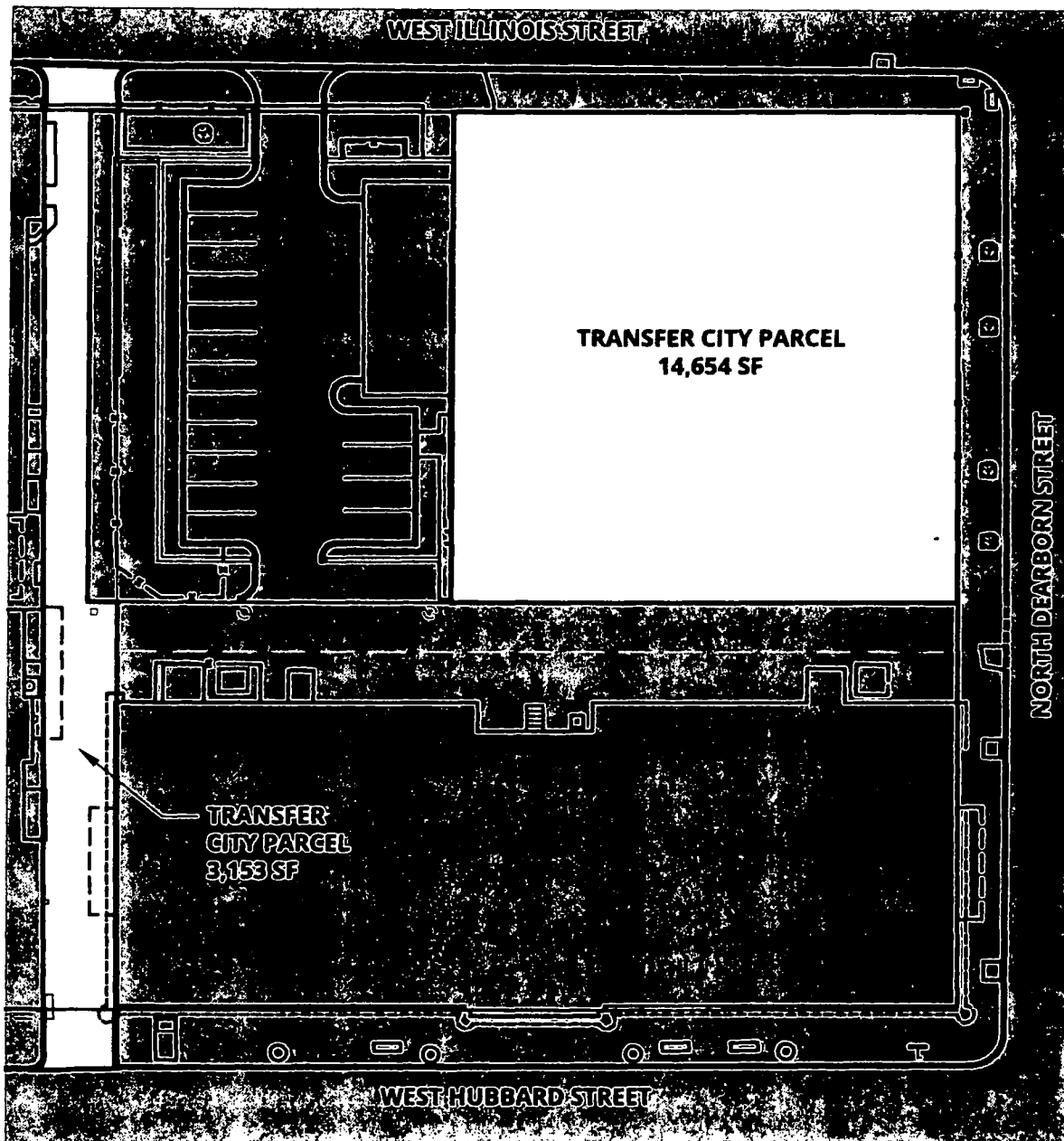

Note: Subject premises is unshaded

FRIEDMAN PROPERTIES
312.644.1100 | friedmanproperties.com

55 W Illinois Street
Transfer City Parcel

02/15/2017

EXHIBIT D

REDEVELOPMENT AGREEMENT

**THIS DOCUMENT
PREPARED BY AND AFTER
RECORDING RETURN TO:**

Peter M. Friedman
Holland & Knight LLP
131 South Dearborn St.
Chicago, IL 60603

Above Space For Recorder's Use Only

DEARBORN FIREHOUSE REDEVELOPMENT AGREEMENT

BETWEEN

THE CITY OF CHICAGO, ILLINOIS, AND

EC 42 DEVELOPER LLC

DATED AS OF NOVEMBER 14, 2018

Table of Contents

	Page
TITLE I – GENERAL MATTERS	1
SECTION 1. RECITALS	1
SECTION 2. DEFINITIONS; RULES OF CONSTRUCTION	2
SECTION 3. GENERAL SEQUENCE AND DESCRIPTION OF PROJECT	7
TITLE II -- PHASE I OF PROJECT	7
SECTION 4. [INTENTIONALLY LEFT BLANK]	7
SECTION 5. GOVERNMENTAL APPROVALS	7
A. ZONING APPROVALS	7
B. FIREHOUSE BUILDING PERMIT APPLICATION	8
C. NECESSARY PROPERTY ACCESS RIGHTS	8
D. ENVIRONMENTAL MATTERS	8
SECTION 6. DESIGN OF NEW FIREHOUSE	11
A. ARCHITECTURE SERVICES	11
B. PREPARATION OF FIREHOUSE CONSTRUCTION DOCUMENTS	11
C. CHICAGO SUSTAINABLE OPERATIONS PLAN	12
D. COMPLETION OF THE FIREHOUSE CONSTRUCTION DOCUMENTS	12
E. SITE ANALYSIS	12
F. CORRECTING ERRORS OR OMISSIONS	13
G. COORDINATION OF DRAWINGS AND SPECIFICATIONS	13
H. COMPLIANCE WITH LAW	13
I. ARCHITECT SITE VISITS	13
J. REPRESENTATIONS OF DEVELOPER	13
K. APPROVAL AND USE OF SUBCONTRACTORS	14
L. REMOVAL OF PERSONNEL AND SUBCONTRACTORS	14
M. OWNERSHIP	14
N. BIDDING	14
O. SALES TAX EXEMPTION	14
SECTION 7. PHASE I CLOSING	15
A. PROPERTY TO BE CONVEYED	15
B. THE ACQUISITION PROPERTY	15
C. PURCHASE PRICE	15
D. CLOSING	15

E.	TITLE COMMITMENT.....	17
F.	PRORATIONS	18
G.	DELIVERY AT CLOSING.....	18
H.	COSTS.....	20
I.	AS-IS; NO WARRANTIES	20
J.	NO BROKER.....	20
K.	SECTION 1031 EXCHANGE.....	20
SECTION 8. CONSTRUCTION OF NEW FIREHOUSE.....		21
A.	THE FIREHOUSE WORK.....	21
B.	CHANGES AND DELAYS.....	26
C.	DEVELOPER'S RESPONSIBILITY FOR DEFECTIVE FIREHOUSE WORK.....	27
D.	BONDS	28
E.	PROJECT FINANCING	29
F.	RELOCATION OF CITY PERSONAL PROPERTY, EQUIPMENT, AND FIXTURES	29
G.	FURNITURE, FIXTURES, AND EQUIPMENT	29
H.	COMPLETION AND ACCEPTANCE OF NEW FIREHOUSE.....	29
I.	DEMOLITION OF EXISTING FD FACILITIES AND OPERATIONS.....	30
J.	LIENS	30
K.	DISPUTES AND REMEDIES.....	31
L.	COMPLIANCE WITH LAWS.....	32
M.	DEVELOPER'S EMPLOYMENT OBLIGATIONS.....	33
N.	TEMPORARY PARKING AGREEMENT.....	37
SECTION 9. INSURANCE.....		37
A.	DEVELOPER INSURANCE.....	37
B.	CITY INSURANCE	38
SECTION 10. FIREHOUSE BUDGET.....		38
A.	DEVELOPER PAYMENT AND OBLIGATIONS.....	38
B.	DEVELOPER'S ACCOUNTING.....	38
C.	FINAL ACCOUNTING.....	38
TITLE III – PHASE II OF PROJECT		39
SECTION 11. REDEVELOPMENT OF THE NEW DEVELOPMENT PROPERTY.....		39
A.	PHASE II COMMENCEMENT	39
B.	PHASE II COMMENCEMENT PRECONDITIONS	39
C.	DEMOLITION OF THE EXISTING STRUCTURES.....	39
D.	CONSTRUCTION OF NEW STRUCTURES.....	40

E.	OPERATION AND USE	40
F.	SIDEWALKS AND PEDESTRIAN PATHWAYS.....	40
G.	PARKING AND PARKING AREAS	40
H.	SIGNAGE	40
I.	REFUSE AND RECYCLING CONTAINERS.....	40
J.	LANDSCAPING AND TREE PRESERVATION	40
K.	MBE/WBE	40
L.	GENERAL USE AND DEVELOPMENT RESTRICTIONS.....	40
SECTION 12. IMPROVEMENTS.....		41
A.	DESCRIPTION OF IMPROVEMENTS.....	41
B.	DESIGN AND CONSTRUCTION OF THE IMPROVEMENTS.	41
C.	UTILITIES.....	41
D.	COMPLETION OF THE PUBLIC IMPROVEMENTS	42
E.	DEDICATION AND MAINTENANCE OF THE PUBLIC IMPROVEMENTS	42
SECTION 13. DEMOLITION AND CONSTRUCTION.....		43
A.	DILIGENT PURSUIT OF CONSTRUCTION	43
B.	CONSTRUCTION TRAFFIC.....	43
C.	PARKING AND STORM WATER MANAGEMENT DURING CONSTRUCTION	44
D.	GENERAL RIGHT TO WITHHOLD PERMITS AND CERTIFICATES.....	44
E.	COMPLETION OF CONSTRUCTION.....	44
F.	AS-BUILT PLANS	45
G.	DAMAGE TO PUBLIC PROPERTY	45
SECTION 14. PAYMENT OF CITY FEES AND COSTS.....		45
A.	NEGOTIATION AND REVIEW FEES	45
B.	OTHER CITY FEES.....	45
SECTION 15. PERFORMANCE SECURITY.....		46
A.	GENERAL REQUIREMENTS	46
B.	MAINTENANCE GUARANTEE FOR PUBLIC IMPROVEMENTS	46
TITLE IV – GENERAL PROVISIONS		46
SECTION 16. LIABILITY AND INDEMNITY OF CITY.....		46
A.	CITY REVIEW	46
B.	INDEMNITY	46
C.	DEFENSE EXPENSE	47
SECTION 17. NATURE, SURVIVAL AND TRANSFER OF OBLIGATIONS.....		47
A.	SUCCESSORS AND TRANSFEREES.....	47

B.	TRANSFER DEFINED	47
C.	MORTGAGEES OF PROPERTY	47
D.	JOINT AND SEVERAL LIABILITY FOR OBLIGATION TO PERFORM THE ARCHITECTURE SERVICES AND FIREHOUSE WORK.....	48
SECTION 18.	TERM.	48
SECTION 19.	EVENTS OF DEFAULT	48
A.	DEVELOPER EVENTS OF DEFAULT	48
B.	EVENTS OF DEFAULT BY THE CITY	49
SECTION 20.	REMEDIES FOR DEFAULT AND ENFORCEMENT.....	49
A.	REMEDIES FOR DEFAULT	49
B.	PREVAILING PARTY	50
SECTION 21.	WARRANTIES AND REPRESENTATIONS.....	50
A.	BY THE CITY	50
B.	BY DEVELOPER.....	50
SECTION 22.	GENERAL PROVISIONS.....	51
A.	NOTICES.....	51
B.	TIME OF THE ESSENCE	52
C.	RIGHTS CUMULATIVE.....	52
D.	NON-WAIVER.....	52
E.	CONSENTS	52
F.	GOVERNING LAW	52
G.	SEVERABILITY	52
H.	ENTIRE AGREEMENT	52
I.	INTERPRETATION.....	52
J.	HEADINGS	53
K.	EXHIBITS/CONFLICTS.....	53
L.	AMENDMENTS AND MODIFICATIONS.....	53
M.	CHANGES IN LAWS	53
N.	NO THIRD PARTY BENEFICIARIES	53
O.	RECORDING	53

**DEARBORN FIREHOUSE REDEVELOPMENT AGREEMENT
BETWEEN
THE CITY OF CHICAGO, ILLINOIS
AND
EC 42 DEVELOPER LLC**

THIS REDEVELOPMENT AGREEMENT (“Agreement”) is made as of the 14th day of November, 2018 (“**Effective Date**”), by and between the **CITY OF CHICAGO**, an Illinois home rule municipal corporation (“**City**”), and **EC 42 DEVELOPER LLC**, an Illinois limited liability company (“**Developer**”).

IN CONSIDERATION OF the recitals and the mutual covenants and agreements set forth in this Agreement, and pursuant to the City’s home rule powers, the Parties hereto agree as follows:

TITLE I – GENERAL MATTERS

SECTION 1. RECITALS.*

A. Within the City of Chicago is a block bounded by Hubbard, Dearborn, Illinois and Clark Streets (“**Development Block**”).

B. Within the Development Block, the City owns (i) an approximately 28,323 square foot property commonly known as 55 West Illinois Street and 444 North Dearborn Street (collectively, “**Existing Firehouse Parcel**”), which is legally described in **Exhibit A** attached hereto; and (ii) a north-south alley (“**Existing Alley Parcel**”), which is legally described in **Exhibit B** attached hereto (collectively, “**Existing City Property**”).

C. Located on the Existing Firehouse Parcel is the Chicago Fire Department’s District One Headquarters and Firehouse as well as the Chicago Fire Department Fire Prevention Bureau, which includes all furniture, fixtures, and other equipment (collectively, “**Existing FD Facilities and Operations**”).

D. Developer, by and through its affiliated companies, owns and controls all portions of the Development Block, other than the Existing City Property (collectively, “**Developer’s Parcel**”), legally described in **Exhibit C** attached hereto.

E. Recognizing the potential public benefits of Developer’s unique ownership of the Developer’s Parcel and Developer’s desire to redevelop a portion of the Development Block, the City is prepared to convey a portion of the Existing City Property, including certain air rights above that part of the Existing City Property not being conveyed to Developer, in exchange for (i) monetary payments to the City; and (ii) the construction on the New Firehouse Parcel by Developer for the City of a new, state-of-the-art, environmentally and energy efficient firehouse with expanded space for the City’s Fire Prevention Bureau, including all furniture, fixtures, and other related equipment for the firehouse and the City’s Fire Prevention Bureau, generally in

*All capitalized words and phrases throughout this Agreement have the meanings set forth in the preamble above and in Section 2 and the other provisions of this Agreement. If a word or phrase is not specifically defined in this Agreement, it has the meaning ascribed to it in the Zoning Code.

accordance with the site plan, floor plans, sections and elevations, performance specifications, and related documents attached hereto as **Exhibit D** ("**Firehouse Design Documents and Specifications**") and the other plans and drawings to be prepared and approved pursuant to this Agreement (collectively, "**New Firehouse**").

F. On April 28, 2017, the Parties entered into a Memorandum of Understanding ("**MOU**") to establish a public-private project providing for the Developer's development and construction within the Development Block of (i) the New Firehouse and (ii) a new, private office use development ("**New Development**") as preliminarily depicted and outlined on **Exhibit E** attached hereto ("**Preliminary New Development Plan**") and pursuant to the Zoning Approvals, as they may be amended from time to time (collectively, "**Project**").

G. The MOU called for the Parties to undertake preliminary discussions and due diligence with regard to the Project and the Existing City Property and attempt to negotiate this Agreement to provide for the Project, to include, at a minimum, the provisions outlined in the MOU. By its terms, the MOU expires upon the Effective Date of this Agreement.

H. The Corporate Authorities, after due and careful consideration, have concluded that the redevelopment and use of the Development Block for the Project and specifically for the construction of the New Firehouse pursuant to and in accordance with this Agreement will serve and be in the best interests of the City.

SECTION 2. DEFINITIONS; RULES OF CONSTRUCTION.

A. **Definitions.** Whenever used in this Agreement, the following terms have the following meanings unless a different meaning is required by the context:

"**2FM**": Defined in Section 5.D.3 of this Agreement.

"**Architect**": Defined in Section 6.I of this Agreement.

"**Acquisition Property**": Defined in Section 7.B of this Agreement.

"**Architecture Services**": Defined in Section 6.A of this Agreement.

"**Bonds**": Defined in Section 8.D of this Agreement.

"**Building Code**": Title 13 of the City Code.

"**City Change Order**": Defined in Section 8.B.1 of this Agreement.

"**City Code**": "The Municipal Code of Chicago", as amended.

"**City Cost Reductions**": Defined in Section 10.C.2 of this Agreement.

"**City Completion Notice**": Defined in Section 8.H.2 of this Agreement.

"**City Parties**": Defined in Section 5.D.10 of this Agreement.

"**City Review Period**": Defined in Section 8.H.2 of this Agreement.

"**City Savings**": Defined in Section 10.C.2 of this Agreement.

"City Savings and Cost Reduction Payment": Defined in Section 10.C.2 of this Agreement.

"Construction Schedule": Defined in Section 8.A.2 of this Agreement.

"Contract Time": Defined in Section 8.A.4 of this Agreement.

"Corporate Authorities": The Mayor and City Council of the City.

"Deed": Defined in Section 7.D.7 of this Agreement.

"Developer Completion Notice": Defined in Section 8.H.1 of this Agreement.

"Developer Parties": Defined in Section 5.D.10 of this Agreement.

"Developer's Parcel": Defined in Section 1.D of this Agreement.

"Development Property": Defined in Section 11 of this Agreement.

"Development Block": Defined in Section 1.A of this Agreement.

"DPD": The City of Chicago Department of Planning and Development.

"Effective Date": The date on which this Agreement has been executed by all of the Parties, which date is deemed to be the date set forth in the first paragraph of page one of this Agreement.

"Escrowee": Near North National Title, LLC.

"Existing Alley Parcel": As legally described on **Exhibit B** and generally defined in Section 1.B of this Agreement.

"Existing City Property": Defined in Section 1.B of this Agreement.

"Existing Firehouse Parcel": Defined in Section 1.B of this Agreement.

"Existing FD Facilities and Operations": Defined in Section 1.C of this Agreement.

"Events of Default": Defined in Section 19.A of this Agreement with respect to Developer and in Section 19.B of this Agreement with respect to the City.

"Final Development Plan": Defined in Section 11.D of this Agreement.

"Firehouse Budget": Maximum price set forth in the cost schedule attached hereto as **Exhibit F**.

"Firehouse Building Permit": Building permits issued pursuant to the City Code necessary to first demolish the West Firehouse Portion of the Existing Firehouse and then to construct the New Firehouse on the New Firehouse Parcel, all in accordance with the Firehouse Construction Documents.

"Firehouse Completion Date": Defined in Section 8.A.4 of this Agreement.

"Firehouse Construction Documents": Defined in Section 6.B of this Agreement.

"Firehouse Final Acceptance": Defined in Section 8.H.3 of this Agreement.

"Firehouse Work": Defined in Section 8.A.1 of this Agreement.

"Force Majeure": Strikes, lockouts, natural disasters (including floods, earthquakes or other "acts of God"), war, terrorist attacks or other factors beyond a Party's reasonable control; provided, however that Force Majeure does not include; (i) delays caused by weather conditions, unless the weather conditions are unusually severe or abnormal considering the location; or (ii) economic hardship, impracticability of performance, or commercial, economic, or market conditions.

"Furniture and Equipment": Defined in Section 8.G of this Agreement.

"General Exceptions": Defined in Section 7.E.1 of this Agreement.

"Ground Lease": Defined in Section 7.D.11 of this Agreement.

"Hazardous Materials": Any toxic substance, hazardous substance, hazardous material, hazardous chemical or hazardous, toxic or dangerous waste defined or qualifying as such in (or for the purposes of) any Environmental Law, or any pollutant or contaminant, and shall include, but not be limited to, petroleum (including crude oil), any radioactive material or by-product material, polychlorinated biphenyls and asbestos in any form or condition.

"Hazmat Survey": Defined in Section 5.D.1 of this Agreement.

"IEPA": Defined in Section 5.D.2 of this Agreement.

"Improvements": The on-site and off-site improvements to be made in connection with the Project, but specifically excluding the New Firehouse and the New Development tower.

"Indemnified Claims": Defined in Section 16.B of this Agreement.

"Monitoring Area": Defined in Section 5.D.9 of this Agreement.

"New Development": Defined in Section 1.F of this Agreement.

"New Development Specifications": The conceptual specifications for the New Development attached hereto as ***Exhibit H***.

"New Firehouse": The new firehouse to be constructed by Developer on the New Firehouse Parcel as generally described in Section 1.E of this Agreement.

"New Firehouse Parcel": The approximately 9,750 square feet of land located within the west portion of the Existing Firehouse Parcel and approximately 795 square feet of land located within the northeast corner of the Existing Alley Parcel up to an elevation of approximately 50 feet CCD, collectively legally described in ***Exhibit I*** attached hereto.

"New Firehouse Sales Tax Exemption": Defined in Section 6 (O) of this Agreement.

"NFR": Defined in Section 5.D.5 of this Agreement.

“Objection Notice”: Defined in Section 7.E.3 of this Agreement.

“Parties”: The City and Developer, collectively.

“Permitted Exceptions”: Defined in Section 7.D.3 of this Agreement.

“Person”: Any natural individual, corporation, partnership, individual, joint venture, trust, estate, association, business, enterprise, proprietorship, or other legal entity of any kind, either public or private, and any legal successor, agent, representative, or authorized assign of the above, or other entity capable of holding title to, or any lesser interest in, real property.

“Phase I Closing”: The date upon which all of the conditions listed in Section 7.D of this Agreement have been satisfied.

“Phase I Commencement”: Defined in Section 8.A.3 of this Agreement.

“Phase I ESA”: Defined in Section 5.D.2 of this Agreement.

“Phase I Logistics Plan”: Defined in Section 8.A.15 of this Agreement and attached as ***Exhibit DD***.

“Phase II”: Defined in Section 11.A of this Agreement.

“Phase II Commencement”: Defined in Section 11.A of this Agreement.

“Phase II Commencement Notice”: Defined in Section 11.A of this Agreement.

“Phase II ESA”: Defined in Section 5.D.2 of this Agreement.

“Phase II Logistics Plan”: Defined in Section 13.B of this Agreement and attached as ***Exhibit GG***.

“Phase II Permit”: Defined in Section 14.A of this Agreement.

“Property Access Rights”: Defined in Section 5.C of this Agreement.

“Public Improvements”: The on-site and off-site improvements which will be constructed by Developer, which will be dedicated to, and accepted by, the City as provided in Section 12.E of this Agreement and listed in ***Exhibit P*** attached hereto as further described in Section 12.B.2 of this Agreement.

“Purchase Price”: Defined in Section 7.C of this Agreement.

“RAP Approval Letter”: Defined in Section 5.D.5 of this Agreement.

“REA”: Defined in Section 7.D.10 of this Agreement.

“Released Claims”: Defined in Section 5.D.10 of this Agreement.

“Required Submittals”: Defined in Section 8.A.5.a of this Agreement.

“Requirements of Law”: All applicable federal, state and City laws, statutes, codes, ordinances, resolutions, rules, and regulations.

“Sales Center Agreement”: Defined in Section 7.D.12 of this Agreement.

“Savings”: Defined in Section 10.C.2 of this Agreement.

“Sister Agencies”: Chicago Public Schools, City Colleges of Chicago, Public Building Commission, Chicago Housing Authority, Chicago Park District, and Chicago Transit Authority.

“Site Restoration”: Site restoration and modification activities to establish a park-like setting suitable for passive outdoor recreational activities.

“SRP”: Defined in Section 5.D.4 of this Agreement.

“Survey”: Defined in Section 7.E.1 of this Agreement.

“Survey Defects”: Defined in Section 7.E.3 of this Agreement.

“Transfer City Property”: The approximately 14,654 square foot portion of the Existing Firehouse Parcel not part of the New Firehouse Parcel and the approximately 3,153 square foot portion of the Existing Alley Parcel not part of the New Firehouse Parcel, depicted on ***Exhibit J*** attached hereto.

“Title Company”: Defined in Section 7.E.1 of this Agreement.

“Title Policy”: Defined in Section 7.E.1 of this Agreement.

“Transferee Assumption Agreement”: Defined in Section 17.A.4 of this Agreement.

“USTs”: Defined in Section 5.D.4 of this Agreement.

“Warranty”: Defined in Sections 8.C.2.a of this Agreement.

“Waste Sections”: Defined in Sections 5.D.13 of this Agreement.

“West Firehouse Portion”: the non-essential west rectangular portion of the Existing FD Facilities and Operations as shown on ***Exhibit Z***, which shall be demolished as part of Phase I Commencement and which land is included in the footprint for the New Firehouse.

“Zoning Approvals”: All approvals issued by the City under the Zoning Code for the New Development and New Firehouse as set forth in Section 5.A of this Agreement.

“Zoning Code”: The “Chicago Zoning Ordinance”, as amended.

B. Rules of Construction.

1. **Grammatical Usage and Construction.** In construing this Agreement, feminine or neutral pronouns are substituted for those masculine in form and vice versa, and plural terms are substituted for singular and singular for plural, in any place in which the context so requires.

2. **Headings.** The headings, titles, and captions in this Agreement have been inserted only for convenience and in no way define, limit, extend, or describe the scope or intent of this Agreement.

3. **Calendar Days.** Unless otherwise provided in this Agreement, any reference in this Agreement to “day” or “days” means calendar days and not business days. If the date for giving of any notice required to be given, or the performance of any obligation, under this Agreement falls on a Saturday, Sunday, or federal holiday, then the notice or obligation may be given or performed on the next business day after that Saturday, Sunday, or federal holiday.

SECTION 3. GENERAL SEQUENCE AND DESCRIPTION OF PROJECT

The Project will be undertaken in two general phases. Phase I will include, among other things, (i) the conveyance to the Developer by the City of the Acquisition Property; (ii) the construction by the Developer of, and relocation of the Existing FD Facilities and Operations to, the New Firehouse; and (iii) the demolition by the Developer of the Existing Firehouse building. Phase II will include, at Developer’s option and discretion, the Developer’s (a) application for, and receipt of, all additional approvals for the New Development, including building permits, and (b) the actual construction of the New Development.

TITLE II -- PHASE I OF PROJECT

SECTION 4. [INTENTIONALLY LEFT BLANK]

SECTION 5. GOVERNMENTAL APPROVALS.

A. Zoning Approvals. Developer has applied for and received the zoning approvals necessary for the construction of the Project on the Development Block, all in accordance with the Firehouse Design Documents and Specifications and the New Development Specifications, all as further specifically identified as follows, including any subsequent amendments to any such zoning approvals approved in accordance with the City Code, which amendments shall be deemed automatically incorporated herein (collectively, “**Zoning Approvals**”):

1. A planned development and site plan for the Development Block, the New Firehouse, and the New Development, and all other land use, zoning, and entitlements required for the Developer to undertake the Project, but not including a building permit for the New Development; and

2. Approval to construct the New Development in accordance with this Agreement and conceptual and massing diagrams and bulk table regulations at the time of Chicago Plan Commission approval of the planned development set forth in Section 5.A.1 of this Agreement, subject to administrative site plan approval prior to issuance of a building permit for the New Development; and

3. An increase in the Floor Area Ratio (as that term is defined in the Zoning Code) for the Development Block to permit the construction of up to 614,722 buildable square feet for the New Development with up to an 11.5 Floor Area Ratio for the Development Block. Developer, in its sole discretion, may reduce the applied for increase in the Floor Area Ratio to not less than 10 for the Development Block; and

4. Approval in the Planned Development for two required loading docks for the New Development;

5. [Intentionally omitted]; and

6. All other forms of zoning relief necessary for Developer to undertake the Project on the Development Block in accordance with this Agreement, but specifically not including any exceptions or variations from (i) the Neighborhood Opportunity Fund Ordinance, 16-14-010 *et seq.* and 17-4-1000 *et seq.*, as may be amended from time to time ("**NOFO**") or (ii) the 2015 Affordable Requirements Ordinance, 2-45-115 *et seq.*, as may be amended from time to time ("**ARO**") of the City Code. The Developer will fully comply with the NOFO and ARO without any variations or exceptions.

B. Firehouse Building Permit Application. Developer shall apply to the City for the Firehouse Building Permit for the Firehouse Work within 30 days after the later of (i) the City granting the Zoning Approvals and (ii) the City approval of the Firehouse Construction Documents in accordance with Section 6.D of this Agreement.

C. Necessary Property Access Rights. In conjunction with the issuance of the Firehouse Building Permit, the City and the Developer will execute mutually agreed upon licenses, easements, rights-of-access, the REA, the Ground Lease and other customary agreements necessary to allow Developer access to the Existing City Property to construct the New Firehouse, the New Development and to manage the ownership responsibilities between the City and Developer in the future ("**Property Access Rights**").

D. Environmental Matters.

1. **Hazardous Materials Survey.** Developer has obtained and the City has reviewed a hazardous materials building survey of the Existing City Property, a copy of which is attached hereto as **Exhibit AA ("Hazmat Survey")**.

2. **Phase I ESA and Subsequent Reporting.** The Developer performed and provided to the City a Phase I Environmental Assessment for the Existing City Property and the Transfer City Parcel titled, "Phase I Environmental Site Assessment," prepared by EGSL Environmental Group Services Limited and dated August 22, 2017, a copy of which is on file with the Department of Planning and Development ("**Phase I ESA**"). The Phase I ESA identified Recognized Environmental Conditions ("**RECs**"). Based on the findings of the Phase I ESA the Developer performed a Phase II Environmental Site Assessment for the Existing City Property and the Transfer City Property titled, "Limited Phase II Subsurface Soil & Soil Gas Vapor Investigation and Thorium Screening Report," prepared by EGSL Environmental Group Services Limited and dated October 25, 2017, a copy of which is on file with the Department of Planning and Development ("**Phase II ESA**"), to ascertain the presence of any environmental impacts associated with the RECs. The Phase II ESA identified chemicals of concern above the Illinois Environmental Protection Agency's ("**IEPA**") Tier 1 residential soil remediation objectives. Upon the City's request, the Developer shall perform additional studies and tests for the purpose of remediating any environmental or health risks which may be associated with the development of the New Firehouse Parcel and the Transfer City Parcel, including, without limitation, updating or expanding the Phase I ESA and performing initial or additional Phase II testing. The Developer shall perform and provide the City with an updated Phase I ESA compliant with ASTM E-1527-13 for the Existing City Property and the Transfer City Parcel prior to and conducted, or updated, within 180 days prior to the conveyance of the Transfer City Parcel.

3. General Cooperation. Any abatement plan with regard to the demolition of the Existing Firehouse recommended in the Hazmat Survey, the Phase I ESA or the Phase II ESA for the Firehouse Work will be included in the Firehouse Construction Documents as part of the application to the City's approval of the Firehouse Building Permit. The Developer shall cooperate and consult with the City at all relevant times (and in all cases upon the City's request) with respect to environmental matters. The City's Department of Fleet and Facility Management ("**2FM**") shall have the right to review and approve the sufficiency of future Phase I and Phase II ESAs and agrees to be the applicant or co-applicant with respect to applications and approvals for any required Remedial Action Plans ("**RAP**") and No Further Remediation ("**NFR**") letters. Prior to the Phase I Closing, Developer will deliver to the City a reliance letter for the Hazmat Survey, Phase I ESA and Phase II ESA as well as any other environmental assessment reports.

4. Site Remediation Program. The Phase II ESA identified contamination above residential remediation objectives as determined by Title 35 of the Illinois Administrative Code ("**IAC**") Part 742 and the Developer must enroll New Firehouse Parcel and the Transfer City Parcel in the IEPA Site Remediation Program ("**SRP**"). Any underground storage tanks ("**USTs**") identified must be removed and closed in accordance with applicable regulations, including Title 41 of IAC Part 175 and any identified leaking USTs must be properly addressed in accordance with 35 IAC Part 734.

5. Remedial Action Approval Letter. At the time the City and Developer enroll the New Firehouse Parcel and the Transfer City Parcel in the SRP, the Developer acknowledges and agrees that it may not commence construction of the New Firehouse until the IEPA issues a Remedial Action Plan Approval Letter ("**RAP Approval Letter**"). Upon receipt of the RAP Approval Letter, the Developer covenants and agrees to complete all remediation work necessary to obtain a Final Comprehensive Residential NFR Letter using all reasonable means. Once issued, the Developer and the City must abide by the terms and conditions of the final NFR letter.

6. City Review. The City shall have the right to review and approve all documents submitted to the IEPA by the City and the Developer under the SRP, as amended or supplemented from time to time, including, without limitation, the SRP documents and any changes thereto, and the Developer's estimate of the cost to perform the remediation work.

7. Developer Responsibilities and Costs. The Developer shall bear sole responsibility for all aspects of the required remediation work including, but not limited to, the removal of pre-existing building foundations, soil exceeding residential remediation objectives as determined by Title 35 of the IAC Part 742, demolition debris, and the removal or treatment of Hazardous Substances. The Developer shall bear sole responsibility for all costs of the required remediation work necessary to obtain the NFR Letter associated with the New Firehouse Parcel and the Transfer City Parcel.

8. Documents. The City and Developer each agree to transmit to the other copies of any additional environmental documents prepared or received with respect to any required remediation work, including, without limitation, any written communications delivered to or received from the IEPA or other regulatory agencies. The Developer acknowledges and agrees that the City will not issue the City Completion Notice (as provided in Section 8.H.2 of this Agreement) for the New Firehouse until the IEPA has issued, and the Developer has recorded with the Cook County Recorder of Deeds, a final NFR Letter for the New Firehouse Parcel.

9. Streeterville Thorium Monitoring Area. The Existing Firehouse is located along the western terminus of the "*Streeterville Thorium Monitoring Area*" depicted on **Exhibit L**

attached hereto ("**Monitoring Area**"), as established by the United States Environmental Protection Agency's ("**USEPA**"). Radiation surveillance is required during any excavation of the Existing City Property as thorium-contaminated materials may exist in some areas. Radiation monitoring is required for ground breaking work on the Existing City Property and in the right-of-way in the Monitoring Area. Where a boundary line runs along a street, thorium monitoring is required for the properties inside the boundary line and for any sidewalks adjacent to the boundary line, including North Dearborn Street. Due to the location of the New Development, the Developer must coordinate with USEPA and complete Streeterville Form No. CDPH.ROW.03 (attached hereto as **Exhibit M**) for all subsurface work involving sidewalks and rights-of-way along Dearborn Street adjacent to the Monitoring Area. When conducting work in the right-of-way the Developer must obtain Chicago Department of Transportation right-of-way permits which will be included with the City's issuance of the New Firehouse Building Permit.

10. Developer Release and Indemnification. In addition to other application provisions of this Agreement, all Firehouse Work must be conducted in accordance with all Requirements of Law. Developer, on behalf of itself and its officers, directors, employees, successors, assigns and anyone claiming by, through or under them (collectively, "**Developer Parties**"), hereby releases, relinquishes and forever discharges the City, its officers, agents and employees (collectively, "**City Parties**"), from and against any and all losses which the Developer ever had, now has, or hereafter may have, whether grounded in tort or contract or otherwise, in any and all courts or other forums, of whatever kind or nature, whether known or unknown, foreseen or unforeseen, now existing or occurring after the Phase I Closing Date, based upon, arising out of or in any way connected with, directly or indirectly (i) any environmental contamination, pollution or hazards associated with the Acquisition Property, the New Development, or any Improvements, facilities or operations located or formerly located thereon, including, without limitation, any release, emission, discharge, generation, transportation, treatment, storage or disposal of Hazardous Materials, or threatened release, emission or discharge of Hazardous Materials; (ii) the structural, physical or environmental condition of the Acquisition Property or the New Development, including, without limitation, the presence or suspected presence of Hazardous Materials in, on, under or about the Acquisition Property or the migration of Hazardous Materials from or to other property; (iii) any violation of, compliance with, enforcement of or liability under any Environmental Laws, including, without limitation, any governmental or regulatory body response costs, natural resource damages or losses arising under CERCLA; and (iv) any investigation, cleanup, monitoring, remedial, removal or restoration work required by any federal, state or local governmental agency or political subdivision or other third party in connection or associated with the New Development or Acquisition Property for any improvements, facilities or operations located or formerly located thereon (collectively, "**Released Claims**"); provided, however, the foregoing release shall not apply to the extent such losses are (a) proximately caused by the willful misconduct of the City Parties, or (b) caused after the Effective Date by the City Parties. Developer shall indemnify, defend (through an attorney reasonably acceptable to the City) and hold the City Parties harmless from and against any and all losses which may be made or asserted by any third parties (including, without limitation, any of the Developer Parties) arising out of or in any way connected with, directly or indirectly, any of the Released Claims, except as provided in the immediately preceding sentence for the City Parties' willful misconduct.

11. Release Runs with the Property. The covenant of release in Paragraph 10 of this Subsection shall run with title to the Acquisition Property, and shall be binding upon all successors and assigns of the Developer Parties with respect to the Acquisition Property and New Firehouse, including, without limitation, each and every person, firm, corporation, limited liability company, trust or other entity owning, leasing, occupying, using or possessing any portion

of the Acquisition Property or the New Firehouse under or through the Developer Parties following the Phase I Closing. The Developer acknowledges and agrees that the foregoing covenant of release constitutes a material inducement to enter into this Agreement, and that, but for such release, the City would not have agreed to enter into this Agreement or to convey the Acquisition Property to the Developer pursuant to this Agreement. It is expressly agreed and understood by and between the Parties that, should any future obligation of the Developer or Developer Parties arise in connection with any environmental, soil or other condition of the Acquisition Property or the New Development, the Parties shall not assert that those obligations must be satisfied in whole or in part by the City because Paragraph 10 of this Subsection contains a full, complete and final release of all such claims, except as provided in such Paragraph for losses proximately caused by the willful misconduct of the City Parties or caused after the Effective Date by the City Parties.

12. Limited City Indemnification. Upon the issuance by the City of the City Completion Notice for the New Firehouse pursuant to Section 8.H.2 of this Agreement, the City agrees to indemnify, defend (through an attorney reasonably acceptable to Developer) and hold the Developer Parties harmless from and against any and all losses which may be made or asserted by any third parties (including, without limitation, any of the City Parties) arising out of or in any way connected with, directly or indirectly, willful misconduct by the City Parties in the New Firehouse after the Certificate of Occupancy is issued for the New Firehouse.

13. Waste Ordinance Provisions. In accordance with Section 11-4-1600(e) of the City Code, the Developer represents and warrants to the City that, to the best of its knowledge as of the Effective Date, its contractors and subcontractors have not violated and are not in violation of any provisions of Section 7-28 or Section 11-4 of the City Code ("**Waste Sections**") in the Acquisition Property. During the period while this Agreement is executory, any violation of the Waste Sections by the Developer, its general or other contractors or any subcontractor, whether or not relating to the performance of this Agreement, constitutes a breach of and an event of default under this Agreement, for which the opportunity to cure, if curable, will be granted only at the sole discretion of the Commissioner. Such breach and default entitles the City to all remedies under this Agreement, at law or in equity. This Paragraph does not limit the duty of the Developer, its general or other contractor and any subcontractors to comply with all applicable Requirement of Laws, in effect now or later, and whether or not they appear in this Agreement. Non-compliance with these terms and conditions may be used by the City as ground for the termination of this Agreement, and may further affect the Developer's eligibility for future contract awards.

SECTION 6. DESIGN OF NEW FIREHOUSE.

A. Architecture Services. Developer shall provide the City all architecture, engineering, planning, and design services necessary for the construction of the New Firehouse and the demolition of the West Firehouse Portion (collectively, "**Architecture Services**"), which Architecture Services shall: (i) consist of, without limitation, the services set forth in this Section.6 and other applicable provisions of this Agreement; and, (ii) be provided in accordance with the provisions of this Section 6 and all other applicable provisions of this Agreement.

B. Preparation of Firehouse Construction Documents. Developer shall, at its sole expense, prepare or have prepared construction documents consisting of drawings and specifications setting forth in detail all of the requirements for the demolition of the West Firehouse Portion and construction of the New Firehouse (collectively, "**Firehouse Construction Documents**"). The Firehouse Construction Documents shall include: (i) all information necessary

for review by governmental authorities for issuance of a demolition permit to remove the West Firehouse Portion and a building permit for the construction of the New Firehouse; and (ii) all usual, customary, and necessary structural, material, mechanical, and electrical designs and specifications needed to construct the New Firehouse in accordance with the Firehouse Construction Documents and this Agreement. If additional details, specifications, clarifications, or revisions are required by governmental authorities, or are required during the course of construction, or if contractors require clarifications, Developer shall provide these items promptly. Any change requested by either Party to the Firehouse Construction Documents shall not be valid or enforceable unless documented by a written City Change Order signed by both Parties.

C. Chicago Sustainable Operations Plan. The Firehouse Construction Documents and all designs and work under the Firehouse Building Permit shall comply with the City standards for new construction and the City's "*Sustainable Operations Plan*" attached hereto as **Exhibit N**.

D. Completion of the Firehouse Construction Documents.

1. **Initial Submittal of Firehouse Construction Documents.** Developer shall submit completed Firehouse Construction Documents to the City for review no later than 365 days after the Effective Date. Developer shall submit no fewer than four sets of the Firehouse Construction Documents, which sets shall be in hard copies and e-copies (flash drives). Upon receipt of the Firehouse Construction Documents, the City shall review and consider approval of the Firehouse Construction Documents, which approval shall not be unreasonably conditioned, withheld or delayed. Upon acceptance by the City of the Firehouse Construction Documents, with no exceptions noted by the City, the Firehouse Construction Documents shall automatically and without further actions of the Parties be deemed incorporated in, and become a part of, this Agreement as **Exhibit O** and the Parties shall use best efforts to schedule the Phase I Closing within 30 days thereafter.

2. **Resubmission of Firehouse Construction Documents.** In the event that the City requests revisions to the Firehouse Construction Documents prior to approval, Developer shall make such revisions within 15 days (unless a longer period of time is agreed to by the Parties) and resubmit to the City for approval. In the event a revision requested by the City expands the scope of work or is a material deviation from the Firehouse Design Documents and Specifications not otherwise agreed to by the Parties, then such change shall be documented in a City Change Order and the Firehouse Budget shall be adjusted in accordance with Section 10 of this Agreement. Upon resubmittal, the City shall review and consider approval of the revised Firehouse Construction Documents, which approval shall not be unreasonably conditioned, withheld or delayed. In the event that the City does not accept the revised Firehouse Construction Documents because of a failure to meet City Code or failure to comply with any provision of this Agreement, Developer shall make revisions and submit them pursuant to the same procedures set forth herein. Once the Firehouse Construction Documents are approved, the Parties shall use best efforts to schedule the Phase I Closing in accordance with Section 7.D of this Agreement.

E. Site Analysis. As part of the Architecture Services, Developer shall (i) review all soil test reports, compactability, environmental, and other testing and inspection reports obtained by the Developer or provided to Developer by the City; and (ii) conduct any and all tests and site analysis reasonably prudent and necessary to provide the Architecture Services, and to demolish the West Firehouse Portion and construct the New Firehouse, all in accordance with this Agreement. Developer acknowledges that it has had the opportunity to inspect, perform due diligence on, and perform site testing on, the Development Block, including, without limitation, the Existing City Property. To the extent there may be hidden conditions that are concealed by

existing improvements, buildings, or finishes or were not susceptible to visual observation that may impact or increase the cost to provide the Architecture Services or the Firehouse Work, Developer assumes the risk and acknowledges and agrees the City shall have no responsibility for any such resulting costs or damages and that such resulting costs and damages shall not be counted against the Firehouse Budget, except to the extent such conditions were caused by the City's willful misconduct.

F. Correcting Errors or Omissions. The Architecture Services shall include correcting any errors and omissions in the Firehouse Construction Documents as soon as reasonable after the City or Developer becomes aware of such defects or is notified of such defects.

G. Coordination of Drawings and Specifications. Developer shall be responsible for the coordination of all drawings and design documents relating to the demolition of the West Firehouse Portion and any other existing improvements necessary for construction of the New Firehouse, regardless of whether such drawings and documents are prepared by Developer, by Developer's architect or consultants, or by others. Developer shall be responsible for coordination and internal checking of all drawings and for the accuracy of all dimensional and layout information contained therein, as fully as if each drawing were prepared by Developer. Developer shall be responsible for the completeness and accuracy of all drawings and specifications submitted by or through Developer and for their compliance with all Requirements of Law.

H. Compliance with Law. All documents produced by Developer as part of the Architecture Services shall comply with all Requirements of Law. The City and Developer each agree to promptly advise the other of any change or modification to any Requirements of Law discovered after the Effective Date, and shall recommend revisions to the Firehouse Construction Documents that will cause compliance of those Firehouse Construction Documents with such changes and an estimate of the impact on the cost to the Firehouse Budget.

I. Architect Site Visits. The Developer's architect that stamps and certifies the Firehouse Construction Documents ("**Architect**") shall visit the Acquisition Property at a minimum weekly during construction of the New Firehouse and at more frequent intervals as the stage or construction demands require to be fully aware of the progress of the Firehouse Work and to ensure that the Firehouse Work is being completed and performed in a manner such that the Firehouse Work when completed will comply with the Firehouse Construction Documents and this Agreement. On the basis of on-site observations as an architect, the Architect shall keep the City informed of the progress and quality of the Firehouse Work, and shall promptly endeavor to identify defects and deficiencies in the Firehouse Work. The Architect and/or general contractor shall submit to the Developer and the City a weekly report detailing the observations made during such visits including unresolved issues and recommendations of the Architect. Personnel performing such site visits shall be qualified and experienced in evaluating conformance of construction of the New Firehouse with the Firehouse Construction Documents, applicable Requirements of Law and this Agreement. The Architect shall coordinate and include 2FM in all site visits and all design and construction meetings related to the work under the Firehouse Construction Permit.

J. Representations of Developer. Developer represents, certifies, and warrants that the Architecture Services shall be performed in accordance with the standards of professional practice, care, and diligence practiced by recognized consulting firms in performing services of a similar nature in existence at the time of performance. Developer further represents and warrants that it is sufficiently experienced and competent, and has the necessary capital, facilities,

organization, staff and subcontractors to provide, perform and complete the Architecture Services in full compliance with, and as required by or pursuant to, this Agreement. The representations and certifications herein expressed shall be in addition to any other representations and certifications expressed in this Agreement, or expressed or implied by law, which are hereby reserved unto the City.

K. Approval and Use of Subcontractors. All subcontractors and subcontracts used by the Developer for the Architecture Services shall be properly licensed and otherwise comply with all Requirements of Law. The retention by Developer of any subcontractor or subcontract shall not relieve Developer of full responsibility and liability for the provision, performance, and completion of the Architecture Services as required by this Agreement. All Architecture Services performed under any subcontract shall be subject to all of the provisions of this Agreement in the same manner as if performed by employees of Developer. For purposes of this Section 6, the term "Developer" shall be deemed also to refer to all subcontractors of Developer, and every subcontract shall include a provision binding the subcontractor to all provisions of this Agreement.

L. Removal of Personnel and Subcontractors. If any personnel or subcontractor fails to perform the Architecture Services in a manner satisfactory to the City and consistent with commonly accepted professional practices, Developer shall immediately upon notice from the City remove and replace such personnel or subcontractor.

M. Ownership. Upon issuance of the New Firehouse Certificate of Occupancy, the Firehouse Design Documents and Specifications, the Firehouse Construction Documents, designs, drawings, plans, specifications, photos, reports, information, observations, calculations, notes, and any other documents, data, or information, in any form, prepared, collected, or received by Developer related to the New Firehouse or the Architectural Services shall be and remain the exclusive property of the City with the Developer retaining a copy of such documents for its files. At the City's request, or upon termination of this Agreement, Developer shall cause such documents to be promptly delivered to the City. In the event that Developer uses subcontractors to develop and create the Firehouse Design Documents and Specifications or the Firehouse Construction Documents, or any part thereof, Developer shall secure ownership rights in such documents for the City.

N. Bidding.

1. **Bid Documents.** Developer shall prepare for the City's approval all bid documents for the Firehouse Work and any supplies and materials for the Firehouse Work, which shall include, without limitation, provision of the Firehouse Construction Documents and any and all other information and documents necessary for potential bidders to finalize the Firehouse Budget.

2. **Contractors.** All contractors doing any work under the Firehouse Building Permit shall be fully and properly licensed by the City and all other government agencies with jurisdiction, shall not have been previously barred or suspended from City work, or by any of the City's Sister Agencies, under the Requirements of Law, and shall have no pending compliance matters with the City or any of the its Sister Agencies.

O. Sales Tax Exemption. City shall assist Developer in obtaining a sales tax exemption for all hard costs items related to construction of the New Firehouse ("***New Fire House Sales Tax Exemption***").

SECTION 7. PHASE I CLOSING.

A. Property to be Conveyed. Pursuant to the terms and conditions of this Agreement, the City agrees to sell and Developer agrees to purchase for the Purchase Price set forth in Section 7.C of this Agreement, right, title, and interest in and to the Acquisition Property by delivering at the Phase I Closing a fully executed, recordable, quit claim deed or other required instrument conveying good and marketable fee simple title to Developer.

B. The Acquisition Property. The Acquisition Property shall consist of:

1. The Transfer City Property and: (i) all improvements thereon, (ii) any appurtenances, rights and easements to or benefiting the Transfer City Property; (iii) any right, title and interest of the City in (a) the fixtures and systems attached or appurtenant to the Transfer City Property, and (b) all intangible personal property with respect to the Transfer City Property, including all permits and licenses, that run with the Transfer City Property;

2. The air rights above the New Firehouse Parcel beginning at the exterior roof line of the New Firehouse, including any FAR bonus granted to the New Firehouse Parcel pursuant to the Zoning Approvals for the Project; and

3. The following subsurfaces below grade level of the New Firehouse Parcel: (i) any subsurface parking area actually constructed (excluding any spaces constructed for the City's exclusive use), and/or (ii) any area required for subsurface caissons necessary for the New Development (but excluding that area covered by the Permanent Parking Agreement).

C. Purchase Price. In addition to Developer's obligations set forth in this Agreement, including, without limitation, the performance of the Firehouse Work, Developer shall pay to the City for the Acquisition Property, the amounts set forth in Subsection D of this Section (collectively, "**Purchase Price**"), to be paid in cash by wire transfer, plus or minus prorations as provided herein, upon the date of the Phase I Closing:

D. Closing. The time of Phase I Closing shall be no later than 30 days after all of the following conditions are satisfied unless the Parties mutually agree to an earlier date:

1. Final Approval of the City (2FM) of the Firehouse Design Documents and Specifications and the Firehouse Construction Documents;

2. Issuance by the City of the Firehouse Building Permit;

3. Approval by the City of the Zoning Approvals for the Project;

4. Approval of the vertical division of the New Firehouse Parcel creating separate legal tax parcels, and any other divisions that are determined by the City to be necessary or prudent for the transfer of the Acquisition Property from the City to Developer, and the payment of all costs related to such divisions;

5. Agreement on Property Access Rights and execution of all related documents;

6. Review by the Chicago Plan Commission of the disposition of portions of the Development Block by the City to Developer in accordance with the requirements of the Interagency Referral Act, 65 ILCS-5/11-12-4.1;

7. The deposit by the City of a Quitclaim Deed ("**Deed**") to the Transfer City Property with Escrowee, which deposit shall be governed by the Escrow Agreement, which must be in a form substantially the same as **Exhibit K**;

8. Payment by the Developer of \$5,000,000 to the City's corporate fund ("**Payment Condition**");

9. Written confirmation from the Developer that the Developer has an executed, non-executory office lease or other similar agreement to a bona fide third party office use tenant with a minimum term of 15 years and covering at least 66 percent of the rentable square footage of the New Development ("**Office Lease Condition**"); and

10. Mutual agreement of the Parties on a Declaration of Covenants, Conditions, Restrictions and Reciprocal Easements ("**REA**"), which REA shall be approved by the City's Commissioner of the Department of Planning and Development, addressing the shared use by the Parties of the Development Block. The REA shall include, at a minimum, the following provisions:

a. Customary provisions regarding maintenance and reciprocal easements (including, but not limited to, vehicular ingress and egress, parking area access and use, snow removal, capital repairs, garbage removal, and security demarcations related to the divisions of parking operations), shared walls, shared foundations, drainage, caissons, arbitration, liens, compliance with laws, real estate taxes, insurance, repair and replacement, and use restrictions on the New Firehouse;

b. A standard 30-day right of first offer in favor of Developer and its permitted assigns to offer to purchase the New Firehouse Parcel in the event the City elects to take the New Firehouse out of service and dispose of the New Firehouse Parcel and related City-owned parking spaces;

c. Temporary construction easements above the New Firehouse.; and

d. The requirements set forth in the REA with regard to the Developer's obligation, and the timing of that obligation in the context of the construction of the New Development, to maintain the private drive to the south of the New Firehouse, 24 hours a day, seven days a week in such a manner that ensures that the drive is clear of vehicular and other obstructions that may interfere with the New Firehouse operations, and to grant an easement to the City for the use of the private drive for the New Firehouse operations.

11. Mutual agreement of the Parties on a ground lease addressing the lease back of the Existing Firehouse by the City from Developer ("**Ground Lease**"), which Ground Lease shall be approved by the City's Commissioner of the Department of Planning and Development. The Ground Lease shall include, at a minimum, the following provisions:

a. Term commencing on the actual date of the Phase I Closing through the date the City vacates the Existing Firehouse;

b. Rental amount - \$0.00; and

c. Requirement that the City will pay costs that the City would otherwise be responsible for as the owner of the Existing Firehouse Parcel.

12. Mutual agreement of the Parties on a license agreement permitting the Developer to maintain a sales center on Existing City Property during construction of the New Development ("**Sales Center Agreement**"), which Sales Center Agreement shall be approved by the City's Commissioner of the Department of Planning and Development.

E. Title Commitment.

1. Delivery to Developer. Within 30 days after the Effective Date, City shall deliver or cause to be delivered to Developer, a title commitment for an owner's title insurance policy issued by Near North Title Company ("**Title Company**") in the amount of the Purchase Price, covering title to the Acquisition Property on or after the Effective Date, showing title in the City subject only to: (a) the general exceptions contained in the policy ("**General Exceptions**"), (b) any and all exceptions caused by the acts of the Developer or its agents, and (c) all easements, encroachments, covenants and restrictions of record. Within 30 days after the Effective Date, City will deliver or cause to be delivered to Developer an ALTA Survey ("**Survey**") covering the Acquisition Property prepared by PLCS Corporation. The title commitment shall be conclusive evidence of good title as therein shown as to all matters insured by the policy, subject only to the exceptions as therein stated. At the closing, City also shall furnish: (i) to Developer, an affidavit of title in customary form covering the date of closing and showing title in City subject only to the Permitted Exceptions (as hereinafter defined); and (ii) to the Title Company, an ALTA Statement and GAP Indemnity in the Title Company's standard form thereof. City shall reasonably cooperate, at no additional cost to Developer, with Developer's efforts to cause the Title Company to issue the owner's policy of title insurance ("**Title Policy**") to be delivered to Developer at the closing free of the General Exceptions.

2. Title Exceptions. The Title Policy shall be subject to only the Permitted Exceptions.

3. Removal of Unpermitted Exceptions. If the title commitment or Survey discloses either unpermitted exceptions or survey matters that render the title unmarketable or which are otherwise unacceptable to Developer ("**Survey Defects**"), Developer shall have 10 days from the date of delivery of the later of the title commitment and the Survey to provide written notice of such unpermitted exceptions or Survey Defects ("**Objection Notice**") to City. Upon receipt of a timely Objection Notice, City shall have 30 days to have such unpermitted exceptions or Survey Defects removed from the commitment or to correct such exceptions or defects or to have the title insurer commit to insure against loss or damage that may be occasioned by such exceptions or Survey Defects, and, in such event, the time of closing shall be 10 days after such corrections are made and all conditions in Section 7.D of this Agreement are satisfied, whichever is later. If City does not have the exceptions removed or correct the unpermitted exceptions and Survey Defects identified in the timely Objection Notice, or in the alternative, does not obtain the commitment for title insurance specified above free of such exceptions or Survey Defects within the specified time, Developer may delay the closing to allow for more time for City to correct the exceptions or may elect, upon notice to City within 10 days after the expiration of the 10-day

period, in Developer's sole discretion to: (a) take title as it then is with the right to deduct from the Purchase Price liens or encumbrances of a definite or ascertainable amount identified in the timely Objection Notice; or (b) terminate this Agreement. For purposes of this Agreement, the term "**Permitted Exceptions**" shall mean (i) this Agreement; (ii) any title or survey matters disclosed by the title commitment or the Survey which are not included in a timely Objection Notice; and (iii) any title or survey matters with respect to which a timely Objection Notice is given, but which has not been cured by City or insured over by the Title Company. Developer agrees that Developer's consummation of closing shall constitute conclusive evidence of Developer's waiver of all uncured matters set forth in the Objection Notice.

F. Prorations. Applicable rents, premiums under assignable insurance policies, water and other utility charges, fuels, prepaid service contracts, general taxes, accrued interest on mortgage indebtedness, if any, and other similar items related to the Acquisition Property shall be adjusted ratably as of the time of closing. The Acquisition Property is exempt from general real estate taxes. The Parties agree to jointly execute a completed Real Estate Transfer Declaration marked "Exempt" in the form required pursuant to the Real Estate Transfer Tax Act of the State of Illinois or by any county or local ordinance with regard to a transfer or transaction tax.

G. Delivery at Closing. The City and Developer shall execute and deliver to each other such items as may be reasonably requested by the other to consummate the Phase I Closing, including, without limitation, the following documents and all necessary forms from the title company:

1. **City Deliveries.** The City shall deliver to the Escrow Agent on or prior to the Phase I Closing the following documents, duly executed and acknowledged where appropriate:

- a. A bill of sale for any personal property that is part of the Acquisition Property;
- b. A Non-Foreign Affidavit and Certification prepared in conformance with IRS regulations;
- c. A properly completed State of Illinois and Cook County Real Estate Transfer Tax Declaration ("**Transfer Declaration**");
- d. A GAP and ALTA Statement in customary form;
- e. Sums due to the Developer, if any, under Section 7 of this Agreement;
- f. A Closing Statement in customary form;
- g. The REA;
- h. The Ground Lease;
- i. The Temporary Parking Agreement, in form and substance agreed to by the Parties and approved by the Commissioner of the Department of Planning and Development prior to the Phase I Closing, as provided in Section 8.N of this Agreement;

j. The Permanent Parking Agreement, which Permanent Parking Agreement shall be approved by the City's Commissioner of Department of Planning and Development prior to the Phase I Closing, and shall, among other matters, provide for (i) termination of the Temporary Parking Agreement; (ii) parking for 30 automobiles in the New Development which shall be owned by the City and which may be in tandem configuration ("**Permanent Parking Spaces**"); (iii) customary representations, warranties, indemnifications, and insurance provisions; and (iv) no monthly parking fee (but the City shall pay its pro-rata share of any common area maintenance and property taxes, if any, as defined in the REA); provided, however that the total number of parking spaces provided under the Permanent Parking Agreement may be increased or decreased upon mutual agreement of the Parties;

k. A Termination of easement approved by the Commissioner of the Department of Planning and Development in recordable form necessary to terminate that certain 12-foot easement dated April 19, 1985 and recorded on April 22, 1985 as Document No. 27520362 with the Cook County Recorder of Deeds;

l. Sales Center Agreement; and

m. Such additional documents as may be necessary or proper to carry out this Agreement.

2. Developer Deliveries. Developer shall deliver to the City, on or prior to the Phase I Closing, the following documents, duly executed and acknowledged where appropriate:

a. A GAP and an ALTA Statement in customary form;

b. A Closing Statement in customary form;

c. Sums due to the City, if any, under Section 7 of this Agreement, including, without limitation, the payment under the Payment Condition pursuant to Paragraph D.8 of this Section;

d. The Purchase Price;

e. The REA;

f. The Ground Lease;

g. The Temporary Parking Agreement;

h. The Permanent Parking Agreement;

i. The written confirmation under the Office Lease Condition pursuant to Paragraph D.9 of this Section;

j. The Performance Security letter of credit pursuant to Section 15 of this Agreement;

k. The Sales Center Agreement; and

l. Such additional documents as may be necessary or proper to carry out this Agreement.

H. **Costs.** City and Developer shall each be responsible for customary costs associated with closing the sale of real estate. City shall be responsible for the payment of Developer's Owner's Title Policy, ½ the deed and money escrow fee, the title charge to insure over the General Exceptions. Developer shall be responsible for the cost of recording of the Deed, any financing documents (if any), ½ the deed and money escrow fees, the cost of any lender escrow fees (if any), the cost of any title insurance premium for Developer's lender title policy (if any), and any additional endorsements required by Developer or Developer's lender, if any. Except as provided herein, Developer shall be responsible for obtaining and paying for the lender title policy, surveys, environmental studies or any other due diligence item that Developer may require.

I. **As-is; No Warranties.** Developer's acceptance of the Deed to the Acquisition Property shall be deemed its acknowledgement that, subject to the City's representations and warranties in this Agreement and the City's performance of its obligations under this Agreement (including, but not limited to, the Zoning Approvals), the conveyance of the Acquisition Property at the Phase I Closing is being made on an "as-is" basis based on the conditions existing as of the Effective Date without warranty or representations of any kind by the City or any of the City's officers, employees, attorneys, agents, or representatives. This acknowledgement shall survive the Phase I Closing date. The City disclaims any and all liability and warranties, express or implied, with respect to the Acquisition Property and Developer hereby assumes the risk that adverse past, present, or future physical characteristics or environmental conditions on any portion of the Acquisition Property may not have been revealed by its inspections or investigation.

J. **No Broker.** The Parties each represent and warrant that they have not contracted with any real estate broker, salesperson or agent in connection with this Agreement. Each Party agrees to indemnify, defend and hold the other harmless against any loss, liability, damage, cost, claim or expense (including reasonable attorney fees) incurred by reason of any brokerage fee, commission or finder's fee which is payable or alleged to be payable to any broker of any kind as a result of this transaction and this representation will survive the Phase I Closing. Notwithstanding any provision of this Agreement to the contrary, the obligations of the Parties pursuant to this Section 7.J shall survive any termination of this Agreement.

K. **Section 1031 Exchange.** Developer may consummate the purchase of the Acquisition Property as part of a so-called like kind exchange (the "Exchange") pursuant to § 1031 of the Internal Revenue Code of 1986, as amended (the "Code"), provided that: (a) except as hereinafter provided, the Phase I Closing shall not be delayed or affected by reason of the Exchange nor shall the consummation or accomplishment of the Exchange be a condition precedent or condition subsequent to the Developer's obligations under this Agreement; (b) the Exchange shall be effected through a qualified intermediary; (c) Developer shall pay any additional costs that would not otherwise have been incurred by its purchase through the Exchange, (d) Developer shall, and hereby does, indemnify, and hold the City harmless from, any loss, cost, damage, liability or expense which may arise or which the City may suffer in connection with, an Exchange; and (e) Developer shall provide the City with written notice not less than seven business days prior to the Phase I Closing. The City shall not by this agreement or acquiescence to the Exchange (i) have its rights under this Agreement affected or diminished in any manner or (ii) be responsible for compliance with or be deemed to have warranted to Developer that the Exchange in fact complies with § 1031 of the Code. In the event Developer is unable to arrange a simultaneous like-kind exchange for the entire Acquisition Property to take place on the Phase I Closing date, then the City shall cooperate with Developer subject to the conditions set forth above in coordinating a non-simultaneous like-kind exchange under § 1031 of the Internal Revenue Code of 1986, as amended.

L. Special City Termination Right. In the event that the Developer fails to satisfy the Payment Condition and the Office Lease Condition within 24 months after the date on which the City accepts and approves the Firehouse Construction Documents pursuant to Section 6.D of this Agreement, the City may provide the Developer with notice ("**City Notice**") that the City intends to terminate this Agreement on the date that is 30 days after the date of the City Notice ("**City Deadline**"). Prior to the City Deadline, the Developer shall have the right to extend the City Deadline by no more than 180 additional days or until June 30, 2022, whichever is later. In addition, the Commissioner may provide one or more additional extensions of the City Deadline if the Commissioner determines one or more such extensions are appropriate and in the best interests of the City. If the Developer does not satisfy the Payment Condition and the Office Lease Condition on or before the City Deadline, including any extensions as providing in this Subsection, the City shall have the right to terminate this Agreement without further notice. If the Developer satisfies the Payment Condition and the Office Lease Condition on or before the City Deadline, including any extensions as provided in this Subsection, the City's right to terminate this Agreement pursuant to the City Notice and this Subsection shall no longer be effective.

SECTION 8. CONSTRUCTION OF NEW FIREHOUSE.

A. The Firehouse Work.

1. Performance of Firehouse Work. Developer, at its sole cost and expense must provide, perform, and complete, or cause to be provided, performed or completed, all of the following, all of which is herein referred to as the "**Firehouse Work**":

a. Labor, Equipment, Materials, and Supplies. Provide, perform, and complete, in the manner described and specified in this Agreement, all necessary Firehouse Work, labor, services, transportation, equipment, materials, apparatus, machinery, tools, fuels, gas, electric, water, waste disposal, information, data, and other means and items necessary to accomplish the construction of the New Firehouse on the New Firehouse Parcel, including but not limited to, the demolition of the West Firehouse Portion all in accordance with the Firehouse Construction Documents.

b. Permits. Procure and furnish all permits, licenses, and other governmental approvals and authorizations necessary in connection therewith. City, without any guaranty of success, will endeavor to assist Developer to expedite any permits, licenses and other governmental approvals or authorizations required from other departments within the City's control.

c. Bonds and Insurance. Procure and furnish all Bonds and all certificates and policies of insurance specified in this Agreement.

d. Taxes. Pay all applicable federal, state, and local taxes.

e. Miscellaneous. Do all other things required of Developer by this Agreement, including without limitation arranging for utility and other services needed for the Firehouse Work and for testing, including the installation of temporary utility lines, wiring, switches, fixtures, hoses, connections, and meters, and providing sufficient sanitary conveniences and shelters to accommodate all workers and all personnel of the Developer engaged in the Firehouse Work.

f. Quality. Provide, perform, and complete all of the foregoing in a good, proper and workmanlike manner, consistent with first class standards of professional and construction practices and in full compliance with, and as required by or pursuant to, this Agreement, and with the greatest economy, efficiency, and expedition consistent therewith, with only new, undamaged and first quality equipment, materials, and supplies.

2. Firehouse Work Schedule. The Firehouse Building Permit shall include a construction schedule for the Firehouse Work approved by the Commissioner of the Department of Planning and Development prior to the issuance of any building permits ("**Construction Schedule**"), which Construction Schedule shall automatically and without further actions of the Parties be deemed incorporated in, and become a part of, this Agreement as **Exhibit Q**. The City shall have no obligation to issue building permits for the Firehouse Work until the Parties agree to a Construction Schedule.

3. Commencement of Firehouse Work. Upon, but not before, the Phase I Closing, and in accordance with the Construction Schedule ("**Phase I Commencement**") the Developer shall be authorized and required to commence the Firehouse Work as provided herein.

4. Prosecution of Firehouse Work. Construction of the New Firehouse will commence within 60 days after the Phase I Closing. Developer shall thereafter diligently and continuously prosecute the Firehouse Work at such a rate as will allow the Firehouse Work to be fully provided, performed, and completed in full compliance with this Agreement and the Construction Schedule not later than 18 months after the Phase I Commencement ("**Firehouse Completion Date**"). The Phase I Commencement, rate of progress, and Firehouse Completion Date are referred to in this Agreement as the "**Contract Time**."

5. Required Submittals.

a. Submittals Required. Developer must submit to 2FM for City approval (i) all documents, data, and information specifically required to be submitted by Developer under Section 6 and 7 of this Agreement; (ii) all such drawings, specifications, descriptive information, and engineering documents, data, and information as may be required, or as may be requested by the City, to show the details of the Firehouse Work, including a complete description of all equipment, materials, and supplies to be provided under this Agreement; and (iii) all design data, structural and operating features, principal dimensions, space required or provided, buffer floors, if required by Developer, clearances required or provided, type and brand of finish, and all similar matters, for all components of the Firehouse Work ("**Required Submittals**").

b. Number and Format. Developer must provide four complete sets for each Required Submittal, which submittals for review may be electronically delivered; with final approved copies of Submittals to be delivered electronically and in hard copy. All Required Submittals, except drawings, must be prepared on white 8 1/2" x 11". Three hard copies with an electronic copy via flash drive of each drawing must be provided. All drawings must be clearly marked in the lower right-hand corner with the names of the City and Developer.

c. Time of Submission and the City's Review. All Required Submittals must be provided to the City no later than the time, if any, specified in this Agreement for their submission or, if no time for submission is specified, in sufficient time, in the City's sole opinion, to permit the City time to review the same prior to the commencement of the part of the Firehouse Work to which they relate and prior to the purchase of any equipment, materials, or supplies that

they describe. The City will have the right to require such corrections as may be necessary to make such Required Submittals conform to this Agreement. All such Required Submittals will, after final processing and review with no exception noted by the City, become a part of this Agreement. No Firehouse Work related to any Required Submittal may be performed by Developer until the City has completed review of such submittal and issued a Building Permit for the New Firehouse. The City's review and stamping of any Required Submittal will be for the sole purpose of examining the general management, design, and details of the proposed Firehouse Work, does not relieve Developer of the entire responsibility for the performance of the Firehouse Work in full compliance with, and as required by or pursuant to this Agreement, and may not be regarded as any assumption of risk or liability by the City.

d. Responsibility of Delay. Developer is responsible for any delay in the Firehouse Work due to delay in providing Required Submittals conforming to this Agreement, except to the extent the delay is caused by the City not reviewing submittals or not acting in accordance with this Agreement.

6. Review and Interpretation of Agreement Provisions. Whenever any equipment, materials or supplies are specified or described in this Agreement or in the Firehouse Construction Documents by using the name or other identifying feature of a proprietary product or the name or other identifying feature of a particular manufacturer or vendor, the specific item mentioned is understood as establishing the type, function and quality desired. Other manufacturers' or vendors' products may be accepted, provided that the products proposed are equivalent in substance and function to those named as determined by the City in its discretion.

7. Erroneous Conflicting Documents. Developer and City each agree to promptly notify the other of any discrepancy, error, omission, ambiguity, or conflict among any of the provisions of this Agreement or the contents of the Firehouse Construction Documents before Developer proceeds with any Firehouse Work affected thereby. If Developer fails to give such notice to the City, then the subsequent decision of the City as to which provision of this Agreement or which portion of the Firehouse Construction Documents governs is final, and any corrective Firehouse Work required does not entitle Developer to any damages, to any additional compensation, to count any costs of corrective Firehouse Work against the Firehouse Budget, or to any delay or extension of the Contract Time; provided, however, that this sentence shall not apply if the City has actual knowledge of the discrepancy, error, omission, ambiguity, or conflict and did not provide prompt notice to the Developer.

8. Installation. If equipment, materials, or supplies furnished by Developer cannot be installed as specified in this Agreement and the Firehouse Construction Documents, Developer will, without counting such costs against the Firehouse Budget, make all modifications required to properly complete the New Firehouse in accordance with this Agreement. Any such modification is subject to the prior review and consent of the City.

9. Conditions at the Firehouse Work Site; Record Drawings. Developer represents and warrants that it has had a sufficient opportunity to conduct a thorough investigation of the Acquisition Property and the surrounding area and has completed such investigation to its satisfaction. Except in the event of willful misconduct or fraud by the City, Developer will have no claim for damages, for additional compensation, or count any additional costs against the Firehouse Budget, or right to any extension of the Contract Time based upon conditions found at, or in the vicinity of, the Acquisition Property. When information pertaining to subsurface, underground or other concealed conditions, soils analysis, borings, test pits, utility locations or conditions, buried structures, condition of existing structures, and other investigations is or has

been provided by the City, or is or has been otherwise made available to Developer by the City, such information is or has been provided or made available solely for the convenience of Developer and is not part of this Agreement. The City assumes no responsibility whatever in respect to the sufficiency or accuracy of such information, and there is no guaranty or warranty, either expressed or implied, that the conditions indicated are representative of those existing at any particular location, or that the conditions indicated may not change, or that unanticipated conditions may not be present.

10. Locating Underground Installation. Developer is solely responsible for locating all existing underground installations by prospecting prior to any scheduled excavation or trenching. Developer must check all dimensions, elevations, and quantities indicated in this Agreement and the Firehouse Construction Documents within the same time period as set forth above for prospecting underground installations. Developer must lay out the Firehouse Work in accordance with this Agreement and the Firehouse Construction Documents, and must establish and maintain such locations, lines and levels. Developer must notify the City of any discrepancy between the dimensions, elevations and quantities indicated in this Agreement and the Firehouse Construction Documents and the conditions of the Development Block or any other errors, omissions or discrepancies which Developer may discover during such inspections. Full instructions will be furnished by the City should such error, omission, or discrepancy be discovered, and Developer must carry out such instructions with respect to the New Firehouse as if originally specified and without any additional compensation and without counting any costs incurred against the Firehouse Budget.

11. Final Reports. Before submitting the Developer Completion Notice to the City for the Firehouse Work, Developer must submit to the City four sets of drawings and reports (hard copies and on flash drives), unless a greater number is specified elsewhere in this Agreement, indicating all material field deviations from this Agreement and the Firehouse Construction Documents.

12. Technical Ability to Perform. Developer represents and warrants that it is sufficiently experienced and competent, and has the necessary capital, facilities, organization, staff and subcontractors, to provide, perform and complete the Firehouse Work in full compliance with, and as required by or pursuant to, this Agreement.

13. Financial Ability to Perform. Developer represents and warrants that it is financially solvent, and Developer has the financial resources necessary to provide, perform and complete the Firehouse Work in full compliance with, and as required by or pursuant to, this Agreement.

14. Time. Developer represents and warrants that it is ready, willing, able, as of the Phase I Commencement Date, to begin the Firehouse Work and that the Contract Time is sufficient time to permit completion of the Firehouse Work in full compliance with, and as required by or pursuant to, this Agreement for the Firehouse Budget, all with due regard to all natural and man-made conditions that may affect the Firehouse Work or the Existing Firehouse Parcel and all difficulties, hindrances, and delays that may be incident to the Firehouse Work.

15. Safety at the Firehouse Work Site. Developer is solely and completely responsible for providing and maintaining safe conditions at the Development Block under Developer's control, including the safety of all persons and property during performance of the Firehouse Work. This requirement applies continuously and is not limited to normal working hours. Developer must take all safety precautions as necessary to comply with the Requirements

of Law and to prevent injury to persons and damage to property. Developer has represented that the construction of the New Firehouse will be undertaken so that the Existing Firehouse will remain open during the Contract Time. The Parties agree to cooperate with the other on these matters, including, but not limited to, the Parties agreement to the construction logistics plans for Phase I and Phase II attached hereto as **Exhibit DD** ("**Phase I Logistics Plan**") and **Exhibit GG**.

16. No Vehicular / Pedestrian Interference. Subject to (a) the closures provided in the Phase I Logistics Plan, and (b) closures otherwise agreed to by the Parties after the Phase I Commencement, Developer must conduct all of its operations without interruption or interference with vehicular and pedestrian traffic on public rights-of-way or alleys. If any public or private right-of-way is rendered unsafe by Developer's operations, Developer must make such repairs or provide such temporary ways or guards as are acceptable in advance to the City and other proper authorities.

17. Cleanliness of the Firehouse Work Site and Environs. Developer will not interfere with the operations of the Existing Firehouse Parcel or the Existing Firehouse during the Contract Time and shall keep the adjacent areas in a clean and orderly condition according to customary practice, at all times during performance of the Firehouse Work. Upon 24-hour notice to Developer (or such shorter notice as may be practical under the circumstances), the City and 2FM will be provided access to the New Firehouse Parcel for site visits.

18. Damage to the Firehouse Work, the Firehouse Work Site, and Other Property. The Firehouse Work will be provided, performed, completed, and maintained at the sole risk and cost of Developer from the commencement date of the Firehouse Work until receipt of the New Firehouse Final Acceptance. Developer is fully responsible for the protection of all public and private property and all persons. Without limiting the foregoing, Developer must, at its own cost and expense, provide all customary permanent and temporary shoring, anchoring and bracing required by the nature of the Firehouse Work in order to make all parts absolutely stable and rigid, even when such shoring, anchoring and bracing is not explicitly specified, and support and protect all buildings, roadways, conduits, wires, water pipes, gas pipes, sewers, pavements, curbs, sidewalks, fixtures and landscaping of all kinds and all other public or private property that may be encountered or endangered in providing, performing, and completing the Firehouse Work. Developer will have no claim against the Firehouse Budget or the City because of any damage or loss to the Firehouse Work or to Developer's equipment, materials, or supplies from any cause whatsoever, including damage or loss due to simultaneous Firehouse Work by others (but excluding damage caused by the City). Developer must, promptly and without charge to the City (unless damage is caused by the City), repair or replace, to the satisfaction of the City, any damage done to, and any loss suffered by, the Firehouse Work and any damage done to, and any loss suffered by, the Existing Firehouse Parcel or other property as a result of the Firehouse Work. Notwithstanding any other provision of this Agreement, Developer's obligations under this Section exist without regard to, and may not be construed to be waived by, the availability or unavailability of any insurance, either of the City or Developer, to indemnify, hold harmless, or reimburse Developer for the cost of any repair or replacement Firehouse Work required by this Section.

19. Subcontractors and Suppliers. As of the Phase I Closing, the general contractor, architect, subcontractors, suppliers, and subcontracts listed in either the Firehouse Budget, the Firehouse Construction Documents, or both are hereby approved by City. Any new or replacement contractor, architect, subcontractor, suppliers, or vendor must be acceptable to, and approved in advance by, the City. The City's approval of any subcontractor, supplier, and subcontract does not relieve Developer of full responsibility and liability for the provision,

performance, and completion of the Firehouse Work in full compliance with, and as required by or pursuant to, this Agreement. All Firehouse Work performed under any subcontract is subject to all of the provisions of this Agreement. Every reference in this Agreement to "Developer" is deemed also to refer to all subcontractors and suppliers of Developer. Every subcontract must include a provision binding the subcontractor or supplier to all provisions of this Agreement.

20. Simultaneous Firehouse Work By Others. The City has the right to perform or have performed such other work as the City may desire in, about, or near the Existing Firehouse Parcel during the performance of the Firehouse Work by Developer ("**City Work**"). Developer must afford the City and other contractors reasonable opportunity for the execution of such other work and must properly coordinate the Firehouse Work with such other work. Any City Work which increases the Firehouse Budget shall be at the City's sole cost and expense and the Developer shall not be penalized for any delay in the Contract Time caused by the City Work.

21. Simultaneous Use of the Existing FD Facilities and Operations. Developer acknowledges that the City will continue to fully utilize and operate the Existing FD Facilities and Operations during the Firehouse Work and Developer shall undertake its Firehouse Work so that it does not interfere with the City's use of the Existing FD Facilities and Operations.

22. Occupancy Prior to City Completion Notice. In consultation with the Developer, the City may have access to any part of the Firehouse Work or the New Firehouse prior to the issuance by the City of the City Completion Notice. Such access must be conducted in such manner as not to damage any of the Firehouse Work or to unreasonably interfere with the progress of the Firehouse Work. No such access may be construed as an acceptance of any of the Firehouse Work or a release or satisfaction of Developer's duty to insure and protect the Firehouse Work, nor may it, unless conducted in an unreasonable manner, be considered as an interference with Developer's provision, performance, or completion of the Firehouse Work. Upon completion of the New Firehouse as documented by the City Completion Notice and issuance by the City of a Certificate of Occupancy, the City will have the right to occupy, use, or place in service any part of the Firehouse Work. Specifically, without limitation, within 90 days prior to the Developer's submission of the "**Developer's Completion Notice**" (pursuant to Subsection H of this Section), the City and 2FM shall have access to the Firehouse Work and the New Firehouse for the purpose of work related to the City's and 2FM's installation and operation of new telephones, marshal lines, and related equipment.

23. Buffer Floors. The Developer intends as part of the construction of the Firehouse Work and the New Firehouse, to construct up to four buffer floors above the completed New Firehouse to allow for occupancy of the New Firehouse during construction of the New Development. The buffer floors shall be enclosed with either (a) glass-and-metal cladding as provided by the Department of Planning and Development; or (b) temporary metal screen panels with design, finish, texture and attachments to be reviewed and approved by the Department of Planning and Development and the Department of Buildings prior to installation and to be installed for no more than one year, after which the permanent glass-and-metal cladding as approved by the Department of Planning and Development shall be installed. The glass-and-metal cladding or temporary metal screen panels shall be installed within 3 months after occupancy of the New Firehouse if Phase 2 has not commenced. For emergency related issues, the City shall have temporary access to the buffer floors at all times during construction of the New Development, if practicable.

B. Changes and Delays.

1. Changes. After the Phase I Closing, the City may request changes to the approved Firehouse Construction Documents in writing and evidenced by a Change Order ("**City Change Order**"). If the Developer determines that the requested City Change Order will increase the Firehouse Budget, Developer shall notify the City within ten (10) business days of receipt of the City Change Order of the estimated costs for such proposed Change Order. In the event that the City desires to continue with the City Change Order after receiving such cost estimate, the City shall provide notice to Developer and the City Change Order will become valid after Developer approves the City Change Order, provided that Developer may not unreasonably withhold such approval. Change Orders will be accounted as provided in Section 10 of this Agreement.

2. Delays.

a. Force Majeure Delays. For any delay caused by a Force Majeure, Developer will, upon timely written application, be entitled to an extension of the Contract Time and adjustment to the Firehouse Budget for a period of time equal to the delay resulting from the Force Majeure. The inability of a subcontractor or supplier of Developer to timely perform Firehouse Work shall not be deemed a cause that cannot be avoided or controlled by Developer and, thus, not a Force Majeure. Except as otherwise provided for in this Agreement, no extension of the Contract Time will be allowed for any other delay in completion of the Firehouse Work except upon written agreement by the Parties.

b. No Compensation for Delays. Except as otherwise provided for in this Agreement, no payment, compensation, damages, or adjustment of any kind, including an adjustment to the Firehouse Budget, other than the extension of the Contract Time provided in Section 8.B.2.a of this Agreement, may be made to, or claimed by, Developer because of a Force Majeure.

C. Developer's Responsibility for Defective Firehouse Work.

1. Inspection; Testing; Correction of Defects.

a. Inspection. Until the City issues the City Completion Notice, all parts of the Firehouse Work are subject to inspection and testing by the City or its designated representatives. Developer must furnish, at its own expense, all reasonable access, assistance, and facilities required by the City for such inspection and testing.

b. Re-Inspection. Re-inspection and re-testing of any Firehouse Work may be ordered by the City at any time within two years after City issues the City Completion Notice, and, if so ordered, any covered or closed Firehouse Work must be uncovered or opened by Developer. If the Firehouse Work is found to be in full material compliance with this Agreement and the Firehouse Construction Documents, then the costs of uncovering, opening, re-inspecting, or re-testing, as the case may be, may be counted against the Firehouse Budget or otherwise paid for by the City. If such Firehouse Work is not in full material compliance with the Firehouse Construction Documents, then Developer shall correct such deficiency and shall not count any related costs against the Firehouse Budget.

c. Correction. Until the City's issuance of the City Completion Notice, Developer must, promptly and without charge, repair, correct, or replace all or any part of the Firehouse Work that is defective, damaged, materially flawed, or materially fails to conform strictly

to the requirements of this Agreement or the Firehouse Construction Documents, but will not apply to the extent of any damage caused by the willful misconduct of the City.

2. Warranty of Firehouse Work.

a. Scope of Warranty. Developer shall assign directly to the City all written warranties received from the general contractor, subcontractors, vendors and suppliers upon receipt of the City Completion Notice. Developer represents and warrants for a period of two years after receipt of the City Completion Notice, the Firehouse Work and all of its components will be free from defects and flaws in design, workmanship, and materials; will strictly conform to the requirements of the Construction Documents and this Agreement; and will be fit, sufficient, and suitable for the purposes expressed in, or reasonably inferred from, this Agreement. The warranty herein expressed is in addition to any other warranties expressed in this Agreement, or expressed or implied by law, which are hereby reserved unto the City but will not apply to any damage caused by the willful misconduct by the City in the use of the New Firehouse (collectively, "**Warranty**").

b. Repairs; Extension of Warranty. For a period of two years after receipt of the City Completion Notice, Developer, promptly and without charge, must correct any failure to fulfill the Warranty. The Warranty may be extended automatically to cover all repaired and replacement parts and labor provided or performed under such Warranty and Developer's obligation to correct Firehouse Work will be extended for a period of two years from the date of such repair or replacement. The time period established in this Subsection relates only to the specific obligation of Developer to correct Firehouse Work and may not be construed to establish a period of limitation with respect to other obligations that Developer has under this Agreement.

c. Subcontractor and Supplier Warranties. All warranties will be obtained by Developer in a form satisfactory to the City and assigned to the City. Acceptance of any assigned warranties or guaranties by the City is a precondition to the issuance of the City Completion Notice and does not relieve Developer of any of its guaranty or warranty obligations under this Agreement.

3. City's Right to Correct. If City gives Developer written notice of any defect, damage, flaw, unsuitability, nonconformity, or failure to meet warranty subject to correction by Developer pursuant to Section 8.C.2 of this Agreement ("**Firehouse Defect Notice**"), Developer shall have sufficient time to cure the Firehouse Defect Notice as may be reasonably required for the type of repair or replacement that may be required including, but limited to, the lead time necessary to obtain any parts that may be required. In the event Developer does not object to or otherwise neglects to make, or undertake with due diligence to make, the necessary corrections to cure the Firehouse Defect Notice within a reasonable time, then, upon written notice to Developer, the City is entitled to make, either with its own forces or with contract forces, the corrections and to recover from Developer all resulting costs, expenses, losses, or damages, including attorneys' fees and administrative expenses.

D. Bonds. Prior to issuance of the Firehouse Building Permit, the Developer shall provide a Performance Bond and a Labor and Material Payment Bond on forms substantially as attached hereto as **Exhibit EE** from a surety company licensed to do business in the State of Illinois with a general rating of A and a financial size category of Class X or better in Best's Insurance Guide, each in the sum of the Firehouse Budget ("**Bonds**"). Developer, at all times will maintain and keep in force, at Developer's expense, the Bonds required hereunder from the

Phase I Commencement through the City Completion Notice date, and during the two year warranty period as provided in Section 8.C.2 of this Agreement.

E. Project Financing. Prior to the issuance of the Firehouse Building Permit, the Developer shall provide, for the City's review and approval, proof of funds equal to no less than the Firehouse Budget to complete the New Firehouse in accordance with this Agreement. The information provided to establish the sufficiency of self-financing under this Subsection shall be considered proprietary and shall not be subject to public disclosure unless such disclosure is required by law.

F. Relocation of City Personal Property, Equipment, and Fixtures. As part of the Firehouse Work and in accordance with the Construction Schedule, Developer shall fully cooperate with the City in order to allow the City and 2FM to remove all City personal property, equipment, and fixtures identified in the Firehouse Construction Documents from the Existing FD Facilities and Operations and relocate and install (if applicable) such personal property, equipment, and fixtures in the New Firehouse or on the New Firehouse Parcel as set forth in the Firehouse Construction Documents or as otherwise directed by the City ("**City Removal**"). The Developer shall provide the City no less than 45 days prior to its submittal of the "**Developer's Completion Notice**" (pursuant to Subsection H of this Section) to complete the City Removal. Any personal property, equipment, or fixtures not removed as part of the City Removal may be disposed of by the Developer.

G. Furniture, Fixtures, and Equipment. As part of the Firehouse Work and in accordance with the Construction Schedule, Developer shall purchase, provide, and install (if applicable and required pursuant to the Firehouse Construction Documents) the furniture, fixtures, and equipment identified in **Exhibit S** hereto (collectively, "**Furniture and Equipment**"). All Furniture and Equipment must be new, undamaged, and still covered by the manufactures' warranties. Upon receipt of the City Completion Notice, Developer shall provide the City a bill of sale for all Furniture and Equipment upon its installation in, or delivery to, the New Firehouse.

H. Completion and Acceptance of New Firehouse.

1. **Developer Completion Notice.** Developer shall provide the City written notice ("**Developer Completion Notice**") when the New Firehouse has been constructed on the New Firehouse Parcel in substantial conformance with the Firehouse Construction Documents and this Agreement including, but not limited to: (i) satisfaction of the obligations set forth in Section 8.F of this Agreement; (ii) delivery to city of a Bill of Sale for the Furniture and Equipment installed in the New Firehouse; (iii) satisfaction of the obligations under Section 7.J of this Agreement; and (iv) confirmation that Developer has satisfied all of the environmental obligations set forth in Section 5.D of this Agreement.

2. **City Completion Notice.** Within 45 days after receipt of the Developer Completion Notice ("**City Review Period**"), the City will undertake such inspections and reviews as are necessary to determine whether the New Firehouse has been constructed on the New Firehouse Parcel in accordance with the Firehouse Construction Documents and this Agreement, including, without limitation, the Developer's obligations under Section 8.F of this Agreement. Upon making that determination, City will provide Developer, prior to expiration of the City Review Period (a) a Certificate of Occupancy for the New Firehouse, (b) a written notice and confirmation that the New Firehouse has been constructed on the New Firehouse Parcel in accordance with the Firehouse Construction Documents and this Agreement (subject to minor punch list items, which shall be addressed in accordance with Section 8.H.3 of this Agreement) ("**City Completion**")

Notice"); and (c) subject to the City's final vacation of the Existing Firehouse, a Demolition Permit for the Existing Firehouse ("**Existing Firehouse Demo Permit**"). The City will vacate and deliver possession of the Existing Firehouse to Developer within 45 days after issuance of the City New Firehouse Final Acceptance, unless otherwise agreed by the Parties. In the event that Developer has failed to satisfy the conditions required for the City Completion Notice, Developer shall continue to diligently and continuously prosecute the Firehouse Work until such conditions have been satisfied. The City Review Period may be extended by mutual written agreement of the Parties.

3. Punch List and Final Acceptance of New Firehouse. The New Firehouse shall be accepted by the City upon completion of the New Firehouse in compliance with the Firehouse Construction Documents and this Agreement. If the City identifies minor punch list items to be completed or corrected during the City Review Period which do not preclude the City from issuing the City Completion Notice, Developer shall complete or correct such items as soon as reasonably is practicable considering the scope of such repairs. Upon completion of all minor punch list items, the City will deliver to Developer a written notice of final acceptance of the New Firehouse ("**New Firehouse Final Acceptance**").

4. City Delay. In the event the City fails to vacate the Existing Firehouse within 45 days after the date of the New Firehouse Final Acceptance ("**Vacation Date**"), the City will pay the Developer \$1,000 per day until the City has vacated the Existing Firehouse. Such amount shall be credited to Developer at the Phase II Commencement.

I. Demolition of Existing FD Facilities and Operations. Upon the vacation of the Existing Firehouse by the City after the New Firehouse Final Acceptance, Developer will timely demolish the remaining Existing FD Facilities and Operations and legally dispose of all materials generated therefrom in accordance with the Construction Schedule, the Firehouse Construction Documents, and all Requirements of Law.

J. Liens.

1. Title. Nothing in this Agreement may be construed as vesting in Developer any right of property in any equipment, materials, supplies, and other items provided under this Agreement after they have been installed in, incorporated into, attached to, or affixed to, the New Firehouse from the Firehouse Work. All such equipment, materials, supplies, and other items will, upon being so installed, incorporated, attached or affixed, become the property of the City, but such title will not release Developer from its duty to insure and protect the Firehouse Work in accordance with the requirements of this Agreement.

2. Waivers of Lien. Developer must, prior to the issuance of the City Completion Notice, furnish to the City such evidence as may be necessary to establish, to the reasonable satisfaction of the City, that no lien against the Firehouse Work, the New Firehouse, any City property, or any public funds held by the City exists in favor of any person whatsoever for or by reason of any equipment, material, supplies, or other item furnished, labor performed, or other thing done in connection with the Firehouse Work or this Agreement ("**Lien**").

a. Removal of Liens. If at any time any notice of any Lien is filed, then Developer must, promptly and without charge to City, discharge, remove, or otherwise dispose of such Lien. Until such discharge, removal, or disposition, the City will have the right to retain from any money payable hereunder an amount that the City, in its sole judgment, deems necessary to

satisfy such Lien and to pay the costs and expenses, including attorneys' fees and administrative expenses, of any actions brought in connection therewith or by reason thereof.

b. Protection of the City Only. This Section does not operate to relieve Developer's surety or sureties from any of their obligations under the Bonds, nor may it be deemed to vest any right, interest, or entitlement in any subcontractor or supplier. The City's retention of funds pursuant to this Section is deemed solely for the protection of its own interests pending removal of such Liens by Developer, and the City will have no obligation to apply such funds to such removal but may, nevertheless, do so where the City's interests would thereby be served.

K. Disputes and Remedies.

1. Dispute Resolution Procedure.

a. Notice of Disputes and Objections. If either party disputes or objects to any requirement, direction, instruction, interpretation, determination, or decision of the other party related to the Firehouse Work, such party must notify the other in writing of its dispute or objection and, if applicable, the amount of any equitable adjustment to the Firehouse Budget or Contract Time, if any; provided, however, that Developer must, nevertheless, proceed to perform the Firehouse Work as required, directed, instructed, interpreted, determined, or decided by the City, without regard to such dispute or objection.

b. Negotiation of Disputes and Objections. To avoid and settle without litigation any such dispute or objection, the City and Developer agree to engage in good faith negotiations for all such disputes ("Dispute"). Within three business days after a Party's receipt of a written notice of a Dispute, a conference between the City and Developer will be held to resolve the Dispute. Within three business days after the end of the conference, the Parties will render their final decisions, in writing, to the other. If one Party objects to the final decision of the other, then, within three business days, such Party shall give the other notice thereof and, in such notice, must state its final demand for settlement of the Dispute.

2. Remedies. If a Party fails or refuses to satisfy a final demand made pursuant to Section 8.K.1 of this Agreement, or to otherwise resolve the Dispute which is the subject of such demand to the satisfaction of the other Party, within 10 days after receipt of such demand, such Party will be entitled to pursue any and all remedies available in contract or in tort, in law or in equity in a court with applicable jurisdiction. Such remedies shall include, but not be limited to, injunctive relief, unless otherwise provided in this Agreement or by law.

3. City Remedies. If the parties have not resolved a Dispute pursuant to Subsection 8.K.1 above, then the City will have the right, at its election and without prejudice to any other remedies provided by law or equity or elsewhere by this Agreement, to pursue any one or more of the following remedies:

a. The City may enforce the Collateral Assignment of General Contractor Agreement and require the General Contractor to complete construction of the New Firehouse in accordance with the terms of this Agreement to the same extent as if General Contractor was the "Developer" under this Agreement.

b. The City may require Developer, within such reasonable time as may be fixed by the City, to complete or correct all or any part of the Firehouse Work that is defective, damaged, flawed, unsuitable, nonconforming or incomplete and to take any or all other

action necessary to bring Developer and the Firehouse Work into compliance with this Agreement.

c. The City may perform or have performed any Firehouse Work necessary for the accomplishment of the results stated in Paragraphs 8.K.1 of this Subsection and withhold or recover from Developer all the cost and expense, including attorneys' fees and administrative costs, incurred by the City in connection therewith.

d. The City may accept the defective, damaged, flawed, unsuitable, nonconforming or incomplete Firehouse Work or part thereof and obtain an equitable credit at the time, and as a precondition of, issuance of the New Firehouse Final Acceptance.

e. The City may, without terminating this Agreement, terminate Developer's rights and obligations under this Agreement with respect to the Firehouse Work and, for the purpose of completing or correcting the Firehouse Work, evict Developer from the Acquisition Property and the New Firehouse Parcel and take possession of all equipment, materials, supplies, tools, appliances, plans, specifications, schedules, manuals, drawings, and other papers relating to the Firehouse Work, whether at the Firehouse Work Site or elsewhere, and either complete or correct the Firehouse Work with its own forces or contracted forces, all at Developer's expense.

f. Upon any termination of this Agreement or of Developer's rights to construct the New Firehouse under this Agreement, or upon the City's enforcement of the Collateral Assignment of General Contractor Agreement and at the City's option exercised in writing, any or all subcontracts and supplier contracts of Developer for the New Firehouse will be deemed to be assigned to the City without any further action being required, but the City may not thereby assume any obligation for payments due under such subcontracts and supplier contracts for any Firehouse Work provided or performed prior to such assignment.

g. The City may recover any damages suffered by the City.

h. The City may enforce the Bonds in accordance with their terms.

i. The City may draw from the Performance Security or Maintenance Guarantee letters of credit provided pursuant to Section 15 of this Agreement.

L. Compliance with Laws.

1. **Compliance Required.** Developer must give all notices, pay all fees, and take all other action that may be necessary to ensure that the Firehouse Work is performed and completed in accordance with all required governmental permits, licenses or other approvals and authorizations that may be required in connection with providing, performing, and completing the Firehouse Work, and with all applicable statutes, ordinances, rules, and regulations, including without limitation the Illinois Prevailing Wage Act, 820 ILCS 130/0.01 *et seq.*; if the Illinois Department of Labor revises the prevailing rate of hourly wages to be paid, the revised rate applies to this Agreement); any other applicable prevailing wage laws; the Fair Labor Standards Act; any statutes regarding qualification to do business; any statutes requiring preference to laborers of specified classes; the Illinois Steel Products Procurement Act, 30 ILCS 565/1 *et seq.*; any statutes prohibiting discrimination because of, or requiring affirmative action based on, race, creed, color, national origin, age, sex, or other prohibited classification, including, without limitation, the Americans with Disabilities Act of 1990, 42 U.S.C. §§ 12101 *et seq.*, the Illinois

Human Rights Act, 775 ILCS 5/1 101 *et seq.*, and the Public Firehouse Works Discrimination Act, 775 ILCS 10/0.01 *et seq.*; and any statutes regarding safety or the performance of the Firehouse Work, including the Illinois Underground Utility Facilities Damage Prevention Act, 220 ILCS 50/1 *et seq.*, and the Occupational Safety and Health Act of 1970, 29 U.S.C. §§ 651 *et seq.*

2. Liability for Fines, Penalties. Developer is solely liable for any fines or civil penalties that are imposed by any governmental or quasi-governmental agency or body that may arise, or be alleged to have arisen, out of or in connection with Developer's, or its subcontractors' or suppliers', performance of, or failure to perform, the Firehouse Work or any part thereof unless the violation is caused by the City.

M. Developer's Employment Obligations.

1. Employment Opportunity. The Developer agrees, and shall contractually obligate its various contractors, subcontractors and any affiliate of the Developer working on the New Firehouse (collectively, the "**Employers**" and individually, an "**Employer**") to agree, that with respect to the provision of services in connection with the construction of the New Firehouse:

a. Neither the Developer nor any Employer shall discriminate against any employee or applicant for employment based upon race, religion, color, sex, national origin or ancestry, age, handicap or disability, sexual orientation, military discharge status, marital status, parental status or source of income as defined in the City of Chicago Human Rights Ordinance, Section 2-160-010 *et seq.* of the Municipal Code, as amended from time to time (the "**Human Rights Ordinance**"). The Developer and each Employer shall take affirmative action to ensure that applicants are hired and employed without discrimination based upon the foregoing grounds, and are treated in a non-discriminatory manner with regard to all job-related matters, including, without limitation: employment, upgrading, demotion or transfer; recruitment or recruitment advertising; layoff or termination; rates of pay or other forms of compensation; and selection for training, including apprenticeship. The Developer and each Employer agrees to post in conspicuous places, available to employees and applicants for employment, notices to be provided by the City setting forth the provisions of this nondiscrimination clause. In addition, the Developer and each Employer, in all solicitations or advertisements for employees, shall state that all qualified applicants shall receive consideration for employment without discrimination based upon the foregoing grounds.

b. To the greatest extent feasible, the Developer and each Employer shall (i) present opportunities for training and employment of low and moderate income residents of the City, and (ii) provide that contracts for work in connection with the construction of the New Firehouse be awarded to business concerns which are located in or owned in substantial part by persons residing in, the City.

c. The Developer and each Employer shall comply with all federal, state and local equal employment and affirmative action statutes, rules and regulations, including, without limitation, the Human Rights Ordinance and the Illinois Human Rights Act, 775 ILCS 5/1-101 *et seq.* (1993), both as amended from time to time, and any regulations promulgated thereunder.

d. The Developer, in order to demonstrate compliance with the terms of this Section 8.M.1, shall cooperate with and promptly and accurately respond to inquiries by the City, which has the responsibility to observe and report compliance with equal employment opportunity regulations of federal, state and municipal agencies.

e. The Developer and each Employer shall include the foregoing provisions of subparagraphs (a) through (d) above in every contract entered into in connection with the construction of the New Firehouse, and shall require inclusion of these provisions in every subcontract entered into by any subcontractors, and every agreement with any affiliate operating on the Property, so that each such provision shall be binding upon each contractor, subcontractor or affiliate, as the case may be.

f. Failure to comply with the employment obligations described in this Section 8.M.1 shall be a basis for the City to pursue remedies under this Agreement and available under applicable Requirements of Law.

2. City Resident Employment Requirement.

a. The Developer agrees, and shall contractually obligate each Employer to agree, that during the construction of the New Firehouse, the Developer and each Employer will comply with the minimum percentage of total worker hours performed by actual residents of Chicago as specified in Section 2-92-330 of the City Code (at least 50 percent); provided, however, that in addition to complying with this percentage, Developer and each Employer shall be required to make good faith efforts to utilize qualified residents of the City in both unskilled and skilled labor positions.

b. The Developer and the Employers may request a reduction or waiver of this minimum percentage level of Chicagoans as provided for in Section 2-92-330 of the City Code in accordance with standards and procedures developed by the chief procurement officer of the City of Chicago.

c. "**Actual residents of Chicago**" shall mean persons domiciled within the City of Chicago. The domicile is an individual's one and only true, fixed and permanent home and principal establishment.

d. The Developer and the Employers shall provide for the maintenance of adequate employee residency records to ensure that actual residents of Chicago are employed on the construction of the New Firehouse. The Developer and the Employers shall maintain copies of personal documents supportive of every Chicago employee's actual record of residence.

e. The Developer and the Employers shall submit weekly certified payroll reports (U.S. Department of Labor Form WH-347 or equivalent) to DPD in triplicate, which shall identify clearly the actual residence of every employee on each submitted certified payroll. The first time that an employee's name appears on a payroll, the date that the Developer or Employer hired the employee should be written in after the employee's name.

f. The Developer and the Employers shall provide full access to their employment records to the chief procurement officer, DPD, the inspector general, or any duly authorized representative thereof. The Developer and the Employers shall maintain all relevant personnel data and records for a period of at least three years after the issuance of the Final Certificate of Completion.

g. At the direction of DPD, the Developer and the Employers shall provide affidavits and other supporting documentation to verify or clarify an employee's actual address when doubt or lack of clarity has arisen.

h. Good faith efforts on the part of the Developer and the Employers to provide work for actual Chicago residents (but not sufficient for the granting of a waiver request as provided for in the standards and procedures developed by the chief procurement officer) shall not suffice to replace the actual, verified achievement of the requirements of this Section 8.M.2 concerning the worker hours performed by actual Chicago residents.

i. If the City determines that the Developer or an Employer failed to ensure the fulfillment of the requirements of this Section 8.M.2 concerning the worker hours performed by actual Chicago residents or failed to report in the manner as indicated above, the City will thereby be damaged in the failure to provide the benefit of demonstrable employment to Chicagoans to the degree stipulated in this Section 8.M.2. Any such non-compliance will be subject to the breach and cure provisions of Section 19.A of this Agreement. The willful falsification of statements and the certification of payroll data may subject the Developer and/or the other Employers or employees to the remedies provided for by applicable Requirements of Law.

j. Nothing herein provided shall be construed to be a limitation upon the "Notice of Requirements for Affirmative Action to Ensure Equal Employment Opportunity, Executive Order 11246" and "Standard Federal Equal Employment Opportunity, Executive Order 11246," or other affirmative action required for equal opportunity under the provisions of this Agreement.

k. The Developer shall cause or require the provisions of this Section 8.M.2 to be included in all construction contracts and subcontracts related to the construction of the New Firehouse.

3. Developer's MBE/WBE Commitment. The Developer agrees for itself and its successors and assigns, and, if necessary to meet the requirements set forth herein, shall contractually obligate its general contractor to agree, that the hard costs associated with the construction of the New Firehouse will include:

a. Consistent with the findings which support, as applicable, (i) the Minority-Owned and Women-Owned Business Enterprise Procurement Program, Section 2-92-420 *et seq.*, City Code (the "**Procurement Program**"), and (ii) the Minority- and Women-Owned Business Enterprise Construction Program, Section 2-92-650 *et seq.*, City Code (the "**Construction Program**," collectively with the Procurement Program, "**MBE/WBE Program**"), and in reliance upon the provisions of the MBE/WBE Program to the extent contained in, and as qualified by, the provisions of this Section 8.M.3, during the course of construction of the New Firehouse; at least 26% of the aggregate hard construction costs shall be expended for contract participation by minority-owned businesses and at least 6% of the aggregate hard construction costs shall be expended for contract participation by women-owned businesses.

b. For purposes of this Section 8.M.3 only:

(i) The Developer (and any party to whom a contract is let by the Developer in connection with the New Firehouse) shall be deemed a "contractor" and this Agreement (and any contract let by the Developer in connection with the New Firehouse) shall be deemed a "contract" or a "construction contract" as such terms are defined in Sections 2-92-420 and 2-92-670, City Code, as applicable.

- (ii) The term "minority-owned business" or "MBE" shall mean a business identified in the Directory of Certified Minority Business Enterprises published by the City's Department of Procurement Services, or otherwise certified by the City's Department of Procurement Services as a minority-owned business enterprise, related to the Procurement Program or the Construction Program, as applicable.
- (iii) The term "women-owned business" or "WBE" shall mean a business identified in the Directory of Certified Women Business Enterprises published by the City's Department of Procurement Services, or otherwise certified by the City's Department of Procurement Services as a women-owned business enterprise, related to the Procurement Program or the Construction Program, as applicable.

c. Consistent with Sections 2-92-440 and 2-92-720, City Code, the Developer's MBE/WBE commitment may be achieved in part by the Developer's status as an MBE or WBE (but only to the extent of any actual work performed on the New Firehouse by the Developer) or by a joint venture with one or more MBEs or WBEs (but only to the extent of the lesser of (i) the MBE or WBE participation in such joint venture, or (ii) the amount of any actual work performed on the New Firehouse by the MBE or WBE); by the Developer utilizing a MBE or a WBE as the general contractor (but only to the extent of any actual work performed on the New Firehouse by the general contractor); by subcontracting or causing the general contractor to subcontract a portion of the construction of the New Firehouse to one or more MBEs or WBEs; by the purchase of materials or services used in the construction of the New Firehouse from one or more MBEs or WBEs; or by any combination of the foregoing. Those entities which constitute both a MBE and a WBE shall not be credited more than once with regard to the Developer's MBE/WBE commitment as described in this Section 8.M.3. In accordance with Section 2-92-730, City Code, the Developer shall not substitute any MBE or WBE general contractor or subcontractor without the prior written approval of DPD.

d. The Developer shall deliver quarterly reports to the City's monitoring staff during the construction of the New Firehouse describing its efforts to achieve compliance with this MBE/WBE commitment. Such reports shall include, *inter alia*, the name and business address of each MBE and WBE solicited by the Developer or the general contractor to work on the New Firehouse, and the responses received from such solicitation, the name and business address of each MBE or WBE actually involved in the construction of the New Firehouse, a description of the work performed or products or services supplied, the date and amount of such work, product or service, and such other information as may assist the City's monitoring staff in determining the Developer's compliance with this MBE/WBE commitment. The Developer shall maintain records of all relevant data with respect to the utilization of MBEs and WBEs in connection with the construction of the New Firehouse for at least five years after completion of the New Firehouse, and the City's monitoring staff shall have access to all such records maintained by the Developer, on prior notice of at least five business days, to allow the City to review the Developer's compliance with its commitment to MBE/WBE participation and the status of any MBE or WBE performing any portion of the construction of the New Firehouse.

e. Upon the disqualification of any MBE or WBE general contractor or subcontractor, if the disqualified party misrepresented such status, the Developer shall be obligated to discharge or cause to be discharged the disqualified general contractor or

subcontractor, and, if possible, identify and engage a qualified MBE or WBE as a replacement. For purposes of this paragraph (e), the disqualification procedures are further described in Sections 2-92-540 and 2-92-730, City Code, as applicable.

f. Any reduction or waiver of the Developer's MBE/WBE commitment as described in this Section 8.M.3 shall be undertaken in accordance with Sections 2-92-450 and 2-92-730, City Code, as applicable.

4. **Pre-Construction Conference and Compliance Requirements.** Not less than seven business days prior to the commencement of the Firehouse Work, the Developer and the Developer's general contractor and all major subcontractors shall meet with DPD monitoring staff regarding compliance with all Section 8.M requirements. During this pre-construction meeting, the Developer shall present its plan to achieve its obligations under this Section 8.M, the sufficiency of which the City's monitoring staff shall approve as a precondition to commencement of the Firehouse Work. During the construction of the New Firehouse, the Developer shall submit all documentation required by this Section 8.M to the City's monitoring staff, including, without limitation, the following: (a) subcontractor's activity report; (b) contractor's certification concerning labor standards and prevailing wage requirements (if applicable); (c) contractor letter of understanding; (d) monthly utilization report; (e) authorization for payroll agent; (f) certified payroll; (g) evidence that MBE/WBE contractor associations have been informed of the New Firehouse via written notice and hearings; and (h) evidence of compliance with job creation/job retention requirements (if any). Failure to submit such documentation on a timely basis, or a determination by the City's monitoring staff, upon analysis of the documentation, that the Developer is not complying with its obligations under this Section 8.M, shall, upon the delivery of written notice to the Developer, be deemed an Event of Default. Upon the occurrence of any such Event of Default, in addition to any other remedies provided in this Agreement, the City may: (x) issue a written demand to the Developer to halt construction of the New Firehouse, (y) withhold any further payment of any City funds to the Developer or the general contractor (if applicable), or (z) seek any other remedies against the Developer available at law or in equity.

N. Temporary Parking Agreement. Prior to the Phase I Closing, the Parties will enter into the temporary parking agreement approved by the City's Commissioner of Department of Planning and Development. The Temporary Parking Agreement will provide, at a minimum, that Developer will provide to the City, at no cost or expense to the City, temporary parking for the City during construction of the New Firehouse and for an agreed time thereafter in Developer's affiliated parking garage located at 60 W. Kinzie ("***Greenway Garage***"). The Temporary Parking Agreement shall also provide (1) parking privileges for 30 automobiles at no cost or expense to the City (unless the Parties otherwise agree on a greater or lesser number of spaces); and (2) a term that will commence on the Phase I Commencement and terminate upon the effective date of the Permanent Parking Agreement.

SECTION 9. INSURANCE.

A. Developer Insurance. As of the Phase I Commencement and continuing through the New Firehouse Final Acceptance, Developer will provide certificates of insurance evidencing the minimum insurance coverages and limits approved of by the City's Commissioner of the Department of Planning and Development prior to the Phase I Closing ("***Developer's Insurance***") for the Acquisition Property and the construction of the New Firehouse. Such policies must be in a form, and from companies, acceptable to the City. Such insurance must provide that no change, modification in, or cancellation of any insurance becomes effective until the expiration of 20 days after written notice thereof has have been given by the insurance company to City.

Developer must, at all times while providing, performing, or completing the Firehouse Work, including, without limitation, at all times while correcting any failure to meet warranties pursuant to Section 8.C.2 of this Agreement, maintain and keep in force, at Developer's expense, Developer's Insurance.

B. City Insurance. As of, and after, the Phase I Commencement and continuing through the New Firehouse Final Acceptance, the City will maintain the various coverages that the City maintains in the normal course of its operations.

SECTION 10. FIREHOUSE BUDGET.

A. Developer Payment and Obligations. In addition to any other costs provided in this Agreement, Developer shall be responsible for all costs for the Firehouse Work, including, without limitation, the construction of the New Firehouse, the demolition of the West Firehouse Portion, and the purchase of Furniture and Equipment, and shall make all payments for the foregoing in immediately available funds. Developer shall not be entitled to any financial contingencies for its obligations under this Agreement.

B. Developer's Accounting. Developer shall maintain an accounting of all of its costs for the Firehouse Work ("**Accounting**"). The Accounting shall include the construction of the New Firehouse and Developer's costs for completing its obligations under Sections 8.F and 8.G of this Agreement. The Accounting shall be open to inspection and copying by the City upon two business days' notice. The City shall also be entitled to inspect and copy all contracts entered into by Developer for the Firehouse Work, which contracts must be made on an "open-book" basis. The Accounting shall not include: (i) any administrative, accounting, insurance, or legal costs to provide the Firehouse Work or coordinate with Developer's subcontractors and suppliers; or (ii) financing costs incurred by Developer.

C. Final Accounting.

1. **Over Budget.** In the event that Developer's total expenditures for the Firehouse Work shown in the Accounting exceed the Firehouse Budget at the time of the New Firehouse Final Acceptance as a result of City Change Orders accepted by Developer in accordance with Section 8.B of this Agreement, the City shall provide Developer a credit at the time, and as a precondition of, the issuance of the New Firehouse Final Acceptance for those amounts in excess of the Firehouse Budget.

2. **Under Budget.** In the event total expenditures for the Firehouse Work shown in the Accounting are less than the Firehouse Budget at the time of the ("**Savings**") then:

a. Developer shall be entitled to retain any Savings up to the first \$2.5 million saved; provided, however, that Savings shall not include the amount that final costs for the Firehouse Work shown in the Accounting are less than the Firehouse Budget as a result of the net of all City Change Orders or other City-initiated value engineering ("**City Cost Reductions**"); and

b. Developer and the City shall share 50-50 any Savings in excess of \$2.5 million and the City's portion of such Savings ("**City Savings**") and any City Cost Reductions shall be paid and otherwise credited to the City at the time, and as a precondition of, the issuance of the New Firehouse Final Acceptance ("**City Savings and Cost Reduction Payment**").

3. Revisions. Any credits issued pursuant to Sections 10.C.1 and 10.C.2 shall be final and not subject to revision or recalculation after the issuance of the New Firehouse Final Acceptance.

TITLE III – PHASE II OF PROJECT

SECTION 11. REDEVELOPMENT OF THE NEW DEVELOPMENT PROPERTY.

Notwithstanding any use or development right that may be applicable or available separately or collectively to the Developer's Parcel or the Acquisition Property (once transferred to Developer at the Phase I Closing) (collectively, "**Development Property**") pursuant to the Zoning Code, the Development Property may be redeveloped, used, operated, and maintained only pursuant to, and in accordance with, the terms and provisions of this Agreement and its exhibits, including, without limitation, the following development restrictions and entitlements:

A. Phase II Commencement. The Developer shall have no obligation to commence construction of any new building on the Development Property. If the Developer desires to commence construction of the New Development on the Development Property, Developer shall issue to the City a written notice ("**Phase II Commencement Notice**") and the following provisions shall apply.

B. Phase II Commencement Preconditions. The Phase II Commencement Notice shall only be valid when the following conditions have been satisfied.

1. Phase I has been completed, including the proper and complete demolition of the Existing Firehouse and the issuance by the City of the City Completion Notice and the New Firehouse Final Acceptance .

2. City approval of the massing and bulk table for the New Development listed in *Exhibit FF* attached hereto.

3. The City has granted administrative approval and any other necessary approvals of the site plan and issuance of a building permit for the New Development.

4. Payment by the Developer of any amounts to be owed under the NOFO at the time the City issues the building permit for the New Development. (Based on the formulas in effect on the Effective Date of this Agreement, the estimated bonus payment would be approximately \$10,899,000 for an 11.5 FAR, and approximately \$7,266,518 for a .10 FAR.

5. In the event that the New Development includes residential units, the payment by the Developer of the cash payment required for the New Development pursuant to the ARO as of the date on which a building permit is issued for the New Development.

6. The issuance by the City, upon proper application by the Developer, of all other approvals necessary to authorize the Developer to commence and undertake the construction of the New Development.

C. Demolition of the Existing Structures. Demolition of any remaining buildings or structures on the City Transfer Property, if any, shall be in strict compliance with the building and engineering plans submitted to, and approved by, the City Department of Buildings for the New Development ("**Final Development Plan**"), the City Code and the Requirements of Law.

D. Construction of New Structures. All buildings and other structures on the Development Property must be constructed and located only as depicted in the Final Development Plan.

E. Operation and Use. Operation of any and all buildings and other structures on the Development Property must at all times be in strict conformance with the applicable provisions of the Zoning Code and the Requirements of Law.

F. Sidewalks and Pedestrian Pathways. As part of the Public Improvements, Developer will install and maintain all off-site sidewalks and demarcated pedestrian pathways on the Development Property, as depicted in the Final Development Plan and listed in **Exhibit P** attached hereto.

G. Parking and Parking Areas.

1. Pursuant to the terms of the Permanent Parking Agreement, off-street tandem parking spaces for 30 cars will be provided to and owned by the City in the Development Property, as depicted in the Final Development Plan, unless the Parties otherwise agree to a lesser or greater amount.

2. All future uses of the Development Property must comply with the applicable off-street parking and loading requirements set forth in the Zoning Code except as may be specifically approved by the City in the Zoning Approvals or otherwise pursuant to the Requirements of Law.

H. Signage. Developer will install and maintain signage on the Development Property pursuant to Chapter 17-12 of the Chicago Zoning Ordinance.

I. Refuse and Recycling Containers. The Developer will provide a sufficient quantity of separate containers for the collection and disposal of refuse and recyclable materials on the Development Property to ensure that such collection and disposal complies with the applicable requirements of the City Code.

J. Landscaping and Tree Preservation. The New Development will comply with all applicable provisions of Title 10, Chapter 32 of the City Code and with Chapter 17-11 of the Zoning Code.

K. MBE/WBE. In the construction and development of the New Development, the Developer agrees for itself and its successors and assigns to comply with the terms and conditions of City of Chicago Mayoral Executive Order No. 2017-2 ("**Executive Order**"), and, if necessary to meet the requirements set forth therein, shall contractually obligate its general contractor to comply with the terms and conditions of the Executive Order.

L. General Use and Development Restrictions. If the Developer undertakes construction of the New Development, the redevelopment and use of, and the construction on, the Development Property, must, except for minor alterations due to final engineering and site work approved by the City, comply, and be in accordance, with all Requirements of Law subject to modification by:

1. this Agreement;

2. the Zoning Approvals; and
3. the Final New Development Plan, and all individual plans and documents which comprise the Final New Development Plan.

SECTION 12. IMPROVEMENTS.

A. Description of Improvements. If the Developer proceeds to undertake the construction of the New Development, then the Developer will, at its sole cost and expense, construct and install all of the Improvements depicted in the Final Development Plan.

B. Design and Construction of the Improvements.

1. **General Standards.** All Improvements for the New Development must be designed and constructed pursuant to and in accordance with the Final Development Plan, and are subject to the reasonable written satisfaction of the City in accordance with the Requirements of Law.

2. **Public Improvements.** As part of the New Firehouse and the New Development, Developer shall install the Public Improvements listed in ***Exhibit P*** attached hereto ("***Public Improvements***"), which Improvements include, without limitation, the installation of stop light and emergency signalization equipment and facilities related to the operations of the New Firehouse. The Public Improvements shall be installed in accordance with the Construction Schedule.

3. **Contract Terms; Prosecution of the Work.** Developer must include in every contract for Public Improvements terms requiring the contractor to prosecute the work diligently and continuously, in full compliance with, and as required by or pursuant to, this Agreement and the Final New Development Plan, and the Requirements of Law, until the work is properly completed, and providing that Developer may take over and prosecute the work if the contractor fails to do so in a timely and proper manner.

4. **Engineering Services.** Developer must provide, at its sole cost and expense, all engineering services for the design and construction of the Public Improvements, by a professional engineer responsible for overseeing the construction of the Public Improvements. Developer must promptly provide the City with the name of a local Developer's representative and a telephone number or numbers at which the Developer's representative can be reached at all times.

5. **City Inspections and Approvals.** All work on the Public Improvements is subject to inspection and approval by City representatives at all times.

6. **Other Approvals.** Where the construction and installation of any Public Improvement requires the consent, permission, or approval of any public agency or private party, Developer must promptly file all applications, enter into all agreements, post all security, pay all fees and costs, and otherwise take all steps that may be required to obtain the consent, permission, or approval. Any consent, permission or approval required of the City shall be responded to in an expeditious manner.

C. Utilities.

1. **Burial of Utilities.** Developer must, at its sole cost and expense, cause to be buried all existing or future electric poles and wires for the New Development and on rights-of-way immediately adjacent to the Development Block in locations and in a manner approved in advance by the City. Developer must cooperate with all utility companies and owners of neighboring properties as may be necessary to ensure that the burial of utilities required pursuant to this Section 12.C.1 does not disrupt utility service to neighboring properties.

2. **Connection.**

a. **Utility Connections.** Developer must, at its sole cost and expense, and in accordance with and pursuant to the Final New Development Plan, upgrade: (i) all public utility connections servicing the New Development; and (ii) the connection of all utilities to facilities located on the New Development.

b. **Connection Fees.** No utilities located on the Development Property may be connected to the sewer and water utilities belonging to the City except in accordance with the applicable provisions of the City Code and upon payment of the connection fees required pursuant to the City Code.

D. Completion of the Public Improvements. The City has the right, but not the obligation, to refuse to issue a final certificate of occupancy for any building or structure located on the Development Block until the Public Improvements are completed by Developer and approved by the City. The foregoing does not preclude the City's issuance of conditional certificates of occupancy pursuant to any applicable provisions of the City Code. The issuance of any building permit or certificate of occupancy by the City at any time prior to completion of all of the Public Improvements by Developer and approval of the Improvements by the City will not confer on Developer any right or entitlement to any other building permit or certificate of occupancy.

E. Dedication and Maintenance of the Public Improvements.

1. **Final Inspection and Approval of the Public Improvements.** Developer will notify the City when it believes that any or all of the Public Improvements have been fully and properly completed, and will request final inspection and approval of the Public Improvement by the City. The notice and request will be given far enough in advance to allow the City time to inspect the Improvements and to prepare a punch list of items requiring repair or correction and to allow Developer time to make all required repairs and corrections prior to the scheduled completion date. Developer must promptly make all necessary repairs and corrections as specified on the punch list. The City is not required to approve any portion of the Public Improvements until: (a) all of the Public Improvements as may be required pursuant to Section 12.B of this Agreement, including all punch list items, have been fully and properly completed; and (b) the City has determined that the specific Public Improvement has been constructed to completion, in accordance with all applicable plans, specifications, and Requirements of Law.

2. **Dedication and Acceptance of Public Improvements.** The execution of this Agreement will not constitute acceptance by the City of any Public Improvements or the Final New Development Plan, if any. The acceptance of ownership of, and responsibility for, a specific approved Improvement as a Public Improvement will be made only by the Corporate Authorities, and only in compliance with the requirements of the Applicable Law.

3. Transfer of Ownership of the Public Improvements and Easements to the City. Upon the approval of, and prior to acceptance of, the Public Improvements to be accepted by the City pursuant to Section 12.E of this Agreement, Developer must execute, or cause to be executed, all documents as the City may request to transfer ownership of, or to provide easements in, the Public Improvements to, and to evidence ownership of the Public Improvements by, the City, free and clear of all liens, claims, encumbrances, and restrictions, unless otherwise approved by the City in writing. Developer will, at the same time, grant, or cause to be granted, to the City all insured easements or other property rights as the City may require to install, operate, maintain, service, repair, and replace the Public Improvements that have not previously been granted to the City, free and clear of all liens, claims, encumbrances, and restrictions, unless otherwise approved by the City in writing.

4. Maintenance of Public Improvements. For a period of two years following acceptance by the City of the Public Improvements, Developer must, at its sole cost and expense, maintain the Public Improvements without any modification, except as specifically approved in writing by the City, in a first rate condition at all times. Developer hereby guarantees, on its behalf and on behalf of its successors to the Developer's Parcel and the Acquisition Parcel, the prompt and satisfactory correction of all defects and deficiencies in any of the Public Improvements that occur or become evident within two years after acceptance of the Public Improvement by the City pursuant to this Agreement. In the event the City determines, in the City's reasonable discretion, that Developer is not adequately maintaining, or has not adequately maintained, any Public Improvement, Developer must, after 10 days' prior written notice from the City, correct it or cause it to be corrected. If the Developer fails to correct the defect, commence the correction of the defect, or diligently pursue correction of the defect to completion, the City, after 10 days' prior written notice to the Developer, may, but will not be obligated to, enter upon that portion of the Development Property necessary for the purpose of performing maintenance work on and to the Public Improvement. In the event that the City causes to be performed any work pursuant to this Section 12.E.4, Developer must, upon demand by the City, pay the costs of the work to the City. If Developer fails to pay the costs, the City will have the right to draw from the Maintenance Guarantee required pursuant to Section 15.B of this Agreement, based on costs actually incurred or on the City's reasonable estimates of costs to be incurred, an amount of money sufficient to defray the entire cost of the work, including legal fees and administrative expenses. In the event any Public Improvement is repaired or replaced pursuant to this Section 12.E.4, the City's right to draw upon the Maintenance Guarantee pursuant to Section 15.B of this Agreement will be extended, as to the repair or replacement, for two full years from the date of the repair or replacement.

SECTION 13. DEMOLITION AND CONSTRUCTION.

A. Diligent Pursuit of Construction. Following Phase II Commencement, Developer will pursue, or cause to be pursued, construction of the New Development in strict compliance with the Zoning Approvals, City Code and the Requirements of Law.

B. Construction Traffic.

1. Construction and Traffic Management Plan. Developer has prepared and City has approved the Phase II Logistics Plan attached hereto as **Exhibit GG** ("**Phase II Logistics Plan**"). Any revisions to the Phase II Logistics Plan will be submitted by Developer for review and approval by the City Commissioner of the Department of Transportation and Chief of the City's Fire Department. The Phase II Logistics Plan will provide and govern, at a minimum, (i) the location, storage, and traffic routes for construction equipment and construction vehicles and (ii)

the location of alternative off-street parking during construction, if required. The City will have no obligation to issue a building permit for the New Development unless and until the City Commissioner of the Department of Transportation and Chief of City's Fire Department have approved, in writing, any requested revisions to the Phase II Logistics Plan. The City agrees to cause any such requests to be promptly and expeditiously reviewed by the City Commissioner of the Department of Transportation and Chief of City's Fire Department; provided, however, that nothing in this Agreement will be deemed or interpreted to require approval of any requested or required revisions to the Phase II Logistics Plan.

2. **Maintenance of Routes of Access.** At all times during the construction of the structures and Improvements, Developer must (a) keep all routes used for construction traffic free and clear of mud, dirt, debris, obstructions, and hazards; and (b) repair any damage caused by construction traffic.

C. Parking and Storm Water Management During Construction. During construction of the New Firehouse and New Development, Developer must:

1. Install temporary and durable surface off street parking on the Development Block for the parking of construction employee vehicles, as necessary, which off-street parking must comply with the standards set forth in the City Code; and

2. Temporarily divert or control any heavy accumulation of storm water away from or through the Development Block in a manner approved in advance by the City Commissioner of the Department of Transportation, which method of diversion must include early installation of storm drains to collect water and convey it to a safe discharge point

D. General Right to Withhold Permits and Certificates. In addition to every other remedy permitted by law for the enforcement of this Agreement, the City has the absolute right to withhold the issuance of any building permit or certificate of occupancy for the New Development at any time when Developer has failed or refused to meet fully any of its obligations under, or is in violation of, or is not in full compliance with, the terms of this Agreement.

E. Completion of Construction.

1. **Removal of Partially Constructed Structures and Improvements.** If Developer fails to diligently pursue all demolition and construction as required in, or permitted by, Sections 11 and 12 of this Agreement to completion within the time period prescribed in the building permit or permits issued by the City for the demolition and construction, as the case may be, and if a perfected application to renew the building permit or permits is not filed within 30 days after the expiration of the permit or permits, Developer must, within 60 days after notice from the City: (a) remove any partially constructed or partially completed buildings, structures, or Improvements from the Development Property; and (b) perform Site Restoration on that portion of the Development Property in which Developer has failed to complete all such demolition and construction, all in accordance with plans approved by the City.

2. **Removal and Restoration by City.** In the event Developer fails or refuses to remove any partially completed buildings, structures, and Improvements, or to perform Site Restoration, as required pursuant to Section 13.E.1 of this Agreement, the City will have, and is hereby granted the right, at its option, to: (a) demolish and/or remove any of the partially completed buildings, structures, and Improvements from any and all portions of the Development Property; (b) perform Site Restoration; and/or (c) cause the buildings, structures, or Improvements

to be completed in accordance with the plans submitted. Developer must fully reimburse the City for all costs and expenses, including legal and administrative costs, incurred by the City for such work. If Developer does not so fully reimburse the City, the City will have the right to draw from the Performance Security and the Maintenance Guarantee, as described in and provided pursuant to Section 15 of this Agreement, an amount of money sufficient to defray the entire cost of the work, including legal fees and administrative expenses. If Developer does not so fully reimburse the City, and the Performance Security and Maintenance Guarantee have no funds remaining in them or are otherwise unavailable to finance such work, then the City will have the right to place a lien on the Development Property for all such costs and expenses in the manner provided by law. The rights and remedies provided in this Section 13.E.2 are in addition to, and not in limitation of, any other rights and remedies otherwise available to the City in this Agreement, at law, and/or in equity.

F. As-Built Plans. After completion of construction of the New Development, Developer must submit to the City final "as-built" plans: (1) related to drainage, grading, storm sewer, sanitary sewer and water mains, and associated structures; and (2) for other final construction documents as required and approved by the City.

G. Damage to Public Property. Developer must maintain the New Development and all streets, sidewalks, and other public property in and adjacent to the New Development in a good and clean condition at all times during construction of Phase II including, but not limited to, (1) promptly clean all mud, dirt, or debris deposited on any street, sidewalk, or other public property in or adjacent to the New Development by Developer or any agent of or contractor hired by, or on behalf of, Developer; and (2) repair any damage that may be caused by the activities of Developer or any agent of or contractor hired by, or on behalf of, Developer.

SECTION 14. PAYMENT OF CITY FEES AND COSTS.

A. Negotiation and Review Fees. In addition to all other costs, payments, fees, charges, contributions, or dedications required by this Agreement or by the Requirements of Law, Developer must pay to the City, contemporaneous with the application for the Phase II building permit ("**Phase II Permit**"), all third-party legal, engineering, and other consulting or administrative fees, costs, and expenses incurred or accrued in connection with the New Development, including, without limitation, the review and processing of a Phase II Permit application; and (2) the negotiation, preparation, consideration, and review of this Agreement. Payment of all fees, costs, and expenses must be made by a certified or cashier's check. Developer acknowledges and agrees that it will continue to be liable for and to pay, promptly after presentation of a written demand or demands for payment, such third-party fees, costs, and expenses incurred in connection with any applications, documents, proposals, or requests for interpretations or amendments of this Agreement, whether formal or informal, of whatever kind, submitted by Developer during the term of this Agreement in connection with the use and redevelopment of the Development Block. Further, Developer acknowledges and agrees that it is liable for and will pay after demand all fees, costs, and expenses incurred by the City for customary publications and recordings required in connection with the above matters.

B. Other City Fees. In addition to all other costs, payments, fees, charges, contributions, or dedications required by this Agreement, Developer must pay to the City all application, inspection, and permit fees, all water and sewer general and special connection fees, tap-on fees, charges, and contributions, and all other fees, charges, and contributions for the New Development pursuant to the Requirements of Law.

SECTION 15. PERFORMANCE SECURITY.

A. General Requirements. As security to the City for the performance by Developer of Developer's obligations pursuant to an in accordance with this Agreement, Developer will cause to be provided to the City a letter of credit, in a total amount equal to the greater of 115% of the estimated cost of completing the Public Improvements required pursuant to this Agreement, which costs are provided in *Exhibit P* hereto, or \$1,500,000.00 ("**Performance Security**"). The Performance Security must be in a form substantially the same as the form of letter of credit attached hereto as *Exhibit HH*. The City will release 50 percent of the Performance Security upon the issuance of the New Firehouse Final Acceptance pursuant to Section 8.H.3 of this Agreement and installation of the permanent glass-and-metal cladding for the buffer floors as provided in Section 8.A.23 of this Agreement. The City will release the balance of the Performance Security in a timely fashion upon the City's approval and, as appropriate, acceptance of the Public Improvements.

B. Maintenance Guarantee for Public Improvements. Following the City's release of the Performance Security for the Public Improvements, the Developer will substitute for the released Performance Security a maintenance guarantee in the form of a letter of credit ("**Maintenance Guarantee**"), which is equal to 15 percent of the actual costs of the completed Public Improvements. The Maintenance Guarantee letter of credit will be in a form substantially the same as the form letter of credit attached hereto as *Exhibit II*. Developer must deposit the Maintenance Guarantee with the City. The Maintenance Guarantee will be effective for a period of two years from the date of acceptance by the City of the Public Improvements and may be utilized by the City in accordance with Section 12.E.4 of this Agreement ("**Maintenance Guarantee Term**"). The City will return to Developer the Maintenance Guarantee upon the end of the Maintenance Guarantee Term if no defects develop in the Public Improvements.

TITLE IV – GENERAL PROVISIONS**SECTION 16. LIABILITY AND INDEMNITY OF CITY.**

A. City Review. Except in the event of the City's willful misconduct, Developer acknowledges and agrees that the City is not, and will not be, in any way liable for any damages or injuries that may be sustained as the result of the City's review and approval of any plans for the New Firehouse and New Development, or the issuance of any approvals, permits, certificates, or acceptances, for the New Firehouse or New Development, and that the City's review and approval of any such plans and issuance of any such approvals, permits, certificates, or acceptances does not, and will not, in any way, be deemed to insure Developer or any of its successors, assigns, tenants and licensees, or any third party, against damage or injury of any kind at any time.

B. Indemnity. Developer agrees to, and does hereby, hold harmless and indemnify the City and all City elected or appointed officials, officers, employees, agents, representatives, engineers, and attorneys, from any and all claims that may be asserted at any time against any of those parties in connection with: (i) the City's review and approval of any plans for the Development Block or the Improvements; (ii) the issuance of any approval, permit, certificate, or acceptance for the Development Block or the Improvements; and (iii) the development, construction, maintenance, or use of any portion of the Development Block or the Improvements ("**Indemnified Claims**"); provided, however, that this indemnity will not apply to willful misconduct or negligence on the part of the City.

C. Defense Expense. Developer hereby agrees to pay all expenses, including legal fees and administrative expenses, incurred by the City in defending itself with regard to any and all of the Indemnified Claims.

SECTION 17. NATURE, SURVIVAL AND TRANSFER OF OBLIGATIONS.

A. Successors and Transferees. To assure that all grantees, successors, assigns, and transferees of Developer and all successor owners of all or any portion of Acquisition Property have notice of this Agreement and the obligations created by it, Developer must:

1. Deposit with the City Clerk, concurrent with the City's approval of this Agreement, any consents or other documents necessary to authorize the City to record this Agreement in the office of the Cook County Recorder of Deeds against the Acquisition Property;

2. Notify the City in writing at least 30 days prior to any date on which Developer transfers a legal or beneficial interest in any portion of the Acquisition Property to a third party;

3. Incorporate this Agreement into any and all real estate sales contracts for "transfers," as that term is defined in Section 17.B of this Agreement, entered into for the sale of all or any portion of the Acquisition Property; and

4. Except as provided in Section 17.C of this Agreement, require, prior to the transfer of all or any portion of the Acquisition Property, or any legal or equitable interest therein, to any third party, the transferee of said portion or interest in the Acquisition Property to execute an enforceable written agreement, in substantially the form of **Exhibit Y** to this Agreement, agreeing to be bound by the provisions of this Agreement ("**Transferee Assumption Agreement**") and to provide the City, upon request, with such reasonable assurance of the financial ability of the transferee to meet those obligations as the City may require. The City agrees that upon a successor becoming bound to the obligation created in the manner provided in this Agreement and providing the financial assurances required pursuant to this Agreement, the liability of Developer will be released to the extent of the transferee's assumption of the liability. The failure of Developer to provide the City with a copy of a Transferee Assumption Agreement fully executed by the transferee and, if requested by the City, with the transferee's proposed assurances of financial capability before completing any transfer, will result in Developer remaining fully liable for all of its obligations under this Agreement but will not relieve the transferee of its liability for all such obligations as a successor to Developer.

B. Transfer Defined. For purposes of this Agreement, the term "transfer" includes any assignment, sale, transfer to a receiver or to a trustee in bankruptcy, transfer in trust, or other disposition of the Development Property, or any beneficial interest in the Development Property, in whole or in part, by voluntary or involuntary sale, foreclosure, merger, sale and leaseback, consolidation, or otherwise.

C. Mortgagees of Property. This Agreement is binding on all mortgagees of the Development Property or other secured parties automatically upon such mortgagee assuming title to the Development Property, in whole or in part, by a foreclosure or a deed in lieu of foreclosure without the necessity of entering into a Transferee Assumption Agreement. Until such time, however, a mortgagee or other secured party has no personal liability hereunder.

D. Joint and Several Liability for Obligation to Perform the Architecture Services and Firehouse Work. Notwithstanding anything to the contrary set forth in Section 17.A of this Agreement, in the event that Developer transfers this Agreement or obligations herein prior to completing the Architecture Services and the Firehouse Work, Developer shall remain jointly and severally liable for the obligations of performing the Architecture Services and the Firehouse Work.

SECTION 18. TERM.

The provisions of this Agreement run with and bind the Acquisition Property and the New Firehouse Parcel and inures to the benefit of, is enforceable by, and obligates the City, Developer, and any of their respective, grantees, successors, assigns, and transferees, including all successor legal or beneficial owners of all or any portion of the Acquisition Property, from the date this Agreement is recorded and until: (a) the Public Improvements are approved and accepted by the City; and (b) all maintenance and guarantee periods established pursuant to this Agreement have concluded. Following such approval, acceptance, and conclusion, the City agrees, upon written request of the Developer, to execute appropriate and recordable evidence of the termination of this Agreement. If any of the privileges or rights created by this Agreement would otherwise be unlawful or void for violation of: (i) the rule against perpetuities or some analogous statutory provision; (ii) the rule restricting restraints on alienation; or (iii) any other statutory or common law rules imposing time limits, then the affected privilege or right will continue only until 21 years after the death of the last survivor of the now living lawful descendants of the former US President John F. Kennedy, or for any shorter period that may be required to sustain the validity of the affected privilege or right.

SECTION 19. EVENTS OF DEFAULT.

A. Developer Events of Default. The following are Developer Events of Default under this Agreement:

1. If any representation made by Developer in this Agreement, or in any certificate, notice, demand or request made by Developer in writing and delivered to the City pursuant to or in connection with this Agreement, proves to be untrue or incorrect in any material respect as of the date made.

2. Default by Developer for a period of 30 days after written notice thereof in the performance or breach of any material covenant contained in this Agreement concerning the existence, structure, or financial condition of Developer; provided, however, that such default or breach will not constitute an Event of Default if such default cannot be cured within said 30 days and Developer, within said 30 days, initiates and diligently pursues appropriate measures to remedy the default and in any event cures such default within a reasonable time period after receipt of such notice.

3. Default by Developer for a period of 30 days after written notice thereof from the City in the performance or breach of any covenant, warranty or obligation contained in this Agreement; provided, however, that such default will not constitute an Event of Default if such default cannot be cured within said 30 days and Developer, within said 30 days, initiates and diligently pursues appropriate measures to remedy the default and in any event cures such default within a reasonable time period after receipt of such notice.

4. The entry of a decree or order for relief by a court having jurisdiction in the premises in respect of Developer in an involuntary case under the federal bankruptcy laws, as now or hereafter constituted, or any other applicable federal or state bankruptcy, insolvency or other similar law, or appointing a receiver, liquidator, assignee, custodian, trustee, sequestrator (or similar official) of Developer for any substantial part of its property, or ordering the winding-up or liquidation of its affairs and the continuance of any such decree or order unstayed and in effect for a period of 90 consecutive days.

5. The commencement by Developer of a voluntary case under the federal bankruptcy laws, as now or hereafter constituted, or any other applicable federal or state bankruptcy, insolvency or other similar law, or the consent by Developer to the appointment of or taking possession by a receiver, liquidator, assignee, trustee, custodian, sequestrator (or similar official) of Developer or of any substantial part of the Developer's Parcel or the Acquisition Property, or the making by any such entity of any assignment for the benefit of creditors or the failure of Developer generally to pay such entity's debts as such debts become due or the taking of action by Developer in furtherance of any of the foregoing, or a petition is filed in bankruptcy by others.

6. Sale, assignment, or transfer of the Acquisition Property except in accordance with the Transferee Assumption provisions in Section 17 of this Agreement.

7. Change in the organizational status of Developer except in accordance with the Transferee Assumption provisions in Section 17 of this Agreement.

8. The Developer abandons redevelopment of the Firehouse Work or the work on the New Development. Abandonment is deemed to have occurred when Firehouse Work or work on the New Development stops for more than 90 days after Phase I Commencement (for the Firehouse Work) or Phase II Commencement (for work on the New Development) for any reason other than Force Majeure, unless otherwise permitted by this Agreement or agreed upon by the parties.

B. Events of Default by the City. The following are City Events of Default under this Agreement:

1. If any material representation made by the City in this Agreement, or in any certificate, notice, demand or request made by the City in writing and delivered to Developer pursuant to or in connection with any of said documents, proves to be untrue or incorrect in any material respect as of the date made.

2. Default by the City for a period of 30 days after written notice thereof from Developer in the performance or breach of any covenant contained in this Agreement; provided, however, that such default will not constitute an Event of Default if such default cannot be cured within said 30 days and the City, within said 30 days, initiates and diligently pursues appropriate measures to remedy the default and in any event cures such default within 90 days after such notice.

SECTION 20. REMEDIES FOR DEFAULT AND ENFORCEMENT.

A. Remedies for Default. In the case of an Event of Default under this Agreement:

1. Except as otherwise provided in this Agreement and subject to the provisions hereinafter set forth, the non-defaulting Party may institute such proceedings in law or in equity, by suit, action, mandamus, or any other proceeding, as may be necessary or desirable in its opinion to cure or remedy such default or breach, including, but not limited to, proceedings to compel specific performance of the defaulting Party's obligations under this Agreement.

2. Pursuant to Section 13.E of this Agreement, the City may, without prejudice to any other rights and remedies available to the City, require: (a) the demolition and removal of any partially constructed or partially completed buildings, structures, or Improvements from the Development Block related to the New Development or New Firehouse; and (b) the performance of Site Restoration. The City may draw from the Performance Security or Maintenance Guarantee letters of credit provided pursuant to Section 15 of this Agreement.

3. In case the City proceeds to enforce its rights under this Agreement and such proceedings are discontinued or abandoned for any reason, then, and in every such case, Developer and the City will be restored respectively to their several positions and rights hereunder, and all rights, remedies and powers of Developer and the City will continue as though no such proceedings had been taken.

B. Prevailing Party. In the event of a judicial proceeding brought by one Party against the other Party, the prevailing Party in the judicial proceeding will be entitled to reimbursement from the unsuccessful Party of all costs and expenses, including reasonable attorneys' fees, incurred in connection with the judicial proceeding.

SECTION 21. WARRANTIES AND REPRESENTATIONS.

A. By the City. The City represents, warrants and agrees as the basis for the undertakings on its part contained in this Agreement that:

1. The City is a municipal corporation duly organized and validly existing under the law of the State of Illinois and has all requisite corporate power and authority to enter into this Agreement;

2. The execution, delivery and the performance of this Agreement and the consummation by the City of the transactions provided for herein and the compliance with the provisions of this Agreement: (i) have been duly authorized by all necessary corporate action on the part of the City; (ii) require no other consents, approvals or authorizations on the part of the City in connection with the City's execution and delivery of this Agreement; and (iii) will not, by lapse of time, giving of notice or otherwise, result in any breach of any term, condition or provision of any indenture, agreement or other instrument to which the City is subject; and

3. To the best of the City's knowledge, there are no proceedings pending or threatened against or affecting the City or the Development Block in any court or before any governmental authority that involves the possibility of materially or adversely affecting the ability of the City to perform its obligations under this Agreement.

B. By Developer. Developer, and the person executing this Agreement on behalf of Developer, represent, warrant, and covenant, as of the Effective Date of this Agreement, that:

1. Developer is an Illinois limited liability company duly organized, validly existing, and qualified to do business in Illinois;

2. Developer has the right, power, and authority to enter into, execute, deliver and perform this Agreement, and Developer is in compliance with all Requirements of Law, the failure to comply with which could affect the ability of Developer to perform its obligations under this Agreement;

3. The execution, delivery and performance by Developer of this Agreement has been duly authorized by all necessary corporate action, and does not and will not violate its organizational documents, as amended and supplemented, any of the applicable Requirements of Law, or constitute a breach of or default under, or require any consent under, any agreement, instrument, or document to which Developer is now a party or by which Developer is now or may become bound;

4. There are no actions or proceedings by or before any court, governmental commission, board, bureau or any other administrative agency pending, threatened, or affecting Developer which would impair its ability to perform under this Agreement;

5. Developer will apply for and will maintain all government permits, certificates, and consents (including, without limitation, appropriate environmental approvals) necessary to conduct its business and to construct and complete its obligations as required by this Agreement; and

6. Developer has sufficient financial and economic resources to implement and complete its obligations under this Agreement;

7. Developer has no knowledge of any liabilities, contingent or otherwise, of Developer which might have a material adverse effect upon its ability to perform its obligations under this Agreement.

SECTION 22. GENERAL PROVISIONS.

A. Notices. All notices required or permitted to be given under this Agreement must be given by the Parties by: (i) personal delivery; (ii) deposit in the United States mail, enclosed in a sealed envelope with first class postage thereon; or (iii) deposit with a nationally recognized overnight delivery service, addressed as stated in this Section 22.A. The address of any Party may be changed by written notice to the other Parties. Any mailed notice will be deemed to have been given and received within three days after the same has been mailed and any notice given by overnight courier will be deemed to have been given and received within 24 hours after deposit. Notices and communications to the Parties will be addressed to, and delivered at, the following addresses:

If to the City:	City of Chicago 121 N. LaSalle Street Chicago, IL 60602 Attention: Commissioner of the Department of Planning and Development
With a copy to:	Holland & Knight LLP 131 S. Dearborn Street, 30th Floor Chicago, IL 60603 Attention: Peter M. Friedman

Peter.Friedman@hklaw.com

If to Developer

EC 42 Developer LLC
350 N. Clark Street
Suite 400
Chicago, IL 60654
Attention: President & General Counsel

With a copy to:

Akerman LLP
John J. George
71 South Wacker Drive
46th Floor
Chicago, IL 60606
Jack.George@akerman.com

B. Time of the Essence. Time is of the essence in the performance of all terms and provisions of this Agreement.

C. Rights Cumulative. Unless expressly provided to the contrary in this Agreement, each and every one of the rights, remedies, and benefits provided by this Agreement are cumulative and are not exclusive of any other such rights, remedies, and benefits allowed by law.

D. Non-Waiver. The City is under no obligation to enforce any of the remedies granted to it in this Agreement. The failure of the City to exercise at any time any such remedy will not be deemed or construed to be a waiver thereof, nor will such failure void or affect the City's right to enforce such right or any other remedy.

E. Consents. Whenever the consent or approval of any Party to this Agreement is required, the consent or approval must be in writing and will not be unreasonably withheld, delayed or conditioned, and, in all matters contained herein, all Parties have an implied obligation of reasonableness, except as may be expressly set forth otherwise.

F. Governing Law. This Agreement is governed by, and enforced in accordance with the internal laws, but not the conflicts of laws rules, of the State of Illinois.

G. Severability. If any term, covenant, condition, or provision of this Agreement is held by a court of competent jurisdiction to be invalid, void or unenforceable, the remaining provisions of this Agreement and the validity, enforceability, and application to any person, firm, corporation, or property will not be impaired thereby, but the remaining provisions will be interpreted, applied, and enforced so as to achieve, as near as may be, the purpose and intent of this Agreement to the greatest extent permitted by applicable law.

H. Entire Agreement. This Agreement constitute the entire agreement between the Parties, superseding any and all prior agreements and negotiations between the Parties, whether written or oral, relating to the subject matter of this Agreement.

I. Interpretation. This Agreement will be construed without regard to the identity of the party who drafted the various provisions of this Agreement. Each provision of this Agreement will be construed as though all Parties to this Agreement participated equally in the drafting of this Agreement. Any rule or construction that a document is to be construed against the drafting party is not applicable to this Agreement.

J. Headings. The table of contents, heading, titles, and captions in this Agreement have been inserted only for convenience and in no way define, limit, extend, or describe the scope or intent of this Agreement.

K. Exhibits/Conflicts. Exhibits A through II attached to this Agreement are, by this reference, incorporated in and made a part of this Agreement. In the event of a conflict between an exhibit to this Agreement and the text of this Agreement, the latter will control.

L. Amendments and Modifications.

1. No amendment or modification to this Agreement will be effective unless and until it is reduced to writing and approved and executed by all Parties to this Agreement in accordance with all applicable statutory procedures.

2. Amendments or modifications to the Final New Development Plan shall be considered and acted on by the City without the same being deemed an amendment or modification to this Agreement provided that all applicable procedural requirements of the Zoning Code and the provisions of this Agreement are satisfied.

M. Changes in Laws. Unless otherwise explicitly provided in this Agreement, any reference to any Requirements of Law is deemed to include any modifications of, or amendments to the Requirements of Law as may, from time to time, hereinafter occur.

N. No Third Party Beneficiaries. No claim as a third party beneficiary under this Agreement by any person, firm, or corporation will be made, or be valid, against the City or Developer.

O. Recording. The City will record this Agreement against the Acquisition Property, at the sole cost and expense of Developer, with the Office of the Cook County Recorder of Deeds promptly following the full execution of this Agreement by the Parties.

[SIGNATURE PAGE FOLLOWS]

IN WITNESS WHEREOF, the Parties have hereunto set their hands on the date first above written.

ATTEST:

[NAME]

CITY OF CHICAGO,
an Illinois home rule municipal corporation

By: _____

David Reifman

Its: Commissioner of Department of Planning
and Development

EC 42 DEVELOPER LLC,
an Illinois limited liability company

By: _____

Albert M. Friedman, its Manager

ACKNOWLEDGMENTS

STATE OF ILLINOIS)
) SS.
COUNTY OF LAKE)

This instrument was acknowledged before me on _____, 2018, by David Reifman, the Commissioner of the Department of Planning and Development of the **CITY OF CHICAGO**, an Illinois municipal corporation, and by _____, the **[POSITION]** of said municipal corporation.

Given under my hand and official seal this ____ day of _____, 2018.

Notary Public

My Commission expires: _____

SEAL

STATE OF Illinois)
) SS.
COUNTY OF COOK)

This instrument was acknowledged before me on _____, 2018, by Albert M. Friedman, the Manager of **EC 42 DEVELOPER LLC**, an Illinois limited liability company.

Given under my hand and official seal this ____ day of _____, 2018.

Notary Public

My Commission expires: _____

SEAL

INDEX OF EXHIBITS

EXHIBIT A	EXISTING FIREHOUSE PARCEL -- LEGAL DESCRIPTION
EXHIBIT B	EXISTING ALLEY PARCEL -- LEGAL DESCRIPTION
EXHIBIT C	DEVELOPER'S PARCEL -- LEGAL DESCRIPTION
EXHIBIT D	FIREHOUSE DESIGN DOCUMENTS AND SPECIFICATIONS
EXHIBIT E	PRELIMINARY NEW DEVELOPMENT PLAN
EXHIBIT F	FIREHOUSE BUDGET
EXHIBIT G	DELETED
EXHIBIT H	NEW DEVELOPMENT SPECIFICATIONS
EXHIBIT I	NEW FIREHOUSE PARCEL -- LEGAL DESCRIPTION
EXHIBIT J	TRANSFER CITY PROPERTY
EXHIBIT K	ESCROW AGREEMENT
EXHIBIT L	STREETERVILLE THORIUM MONITORING AREA
EXHIBIT M	STREETERVILLE FORM CDPH.ROW.03
EXHIBIT N	CHICAGO SUSTAINABLE OPERATIONS PLAN
EXHIBIT O	FIREHOUSE CONSTRUCTION DOCUMENTS
EXHIBIT P	PUBLIC IMPROVEMENTS
EXHIBIT Q	CONSTRUCTION SCHEDULE
EXHIBIT R	DELETED
EXHIBIT S	FURNITURE, FIXTURES, AND EQUIPMENT TO BE PURCHASED FOR FIREHOUSE
EXHIBIT T	DELETED
EXHIBIT U	DELETED
EXHIBIT V	DELETED
EXHIBIT W	DELETED
EXHIBIT X	DELETED
EXHIBIT Y	TRANSFeree ASSUMPTION AGREEMENT
EXHIBIT Z	WEST FIREHOUSE PORTION
EXHIBIT AA	HAZMAT SURVEY
EXHIBIT BB	DELETED
EXHIBIT CC	DELETED
EXHIBIT DD	PHASE I LOGISTICS PLAN
EXHIBIT EE	PERFORMANCE BOND AND LABOR AND MATERIALS BOND

EXHIBIT FF	MASSING AND BULK TABLE FOR NEW DEVELOPMENT
EXHIBIT GG	PHASE II LOGISTICS PLAN
EXHIBIT HH	PERFORMANCE SECURITY LETTER OF CREDIT
EXHIBIT II	MAINTENANCE GUARANTEE LETTER OF CREDIT

EXHIBIT A

EXISTING FIREHOUSE PARCEL

EXCEPT THE SOUTH 99 FEET OF THE FOLLOWING DESCRIBED PROPERTY TAKEN AS A TRACT: LOTS 11 TO 25 AND LOTS 10 AND 26 EXCEPT THE WEST 8 FEET THEREOF, TOGETHER WITH THE 100 FOOT STRIP OF LAND LYING WEST OF AND ADJOINING LOTS 14 TO 22 INCLUSIVE AND EAST OF AND ADJOINING LOTS 13 AND 23, ALSO THE EAST-WEST STRIP OF LAND LYING SOUTH OF AND ADJOINING LOTS 10 TO 13 INCLUSIVE AND NORTH OF AND ADJOINING LOTS 23 TO 26 INCLUSIVE EXCEPT THE WEST 8 FEET THEREOF, AS VACATED BY CITY ORDINANCE PASSED SEPTEMBER 26, 1872 ALL IN BLOCK 7 OF JOHN S. BUSSING'S SUBDIVISION OF BLOCKS 7 AND 10 IN WOLCOTT'S ADDITION TO CHICAGO IN THE EAST ½ OF THE NORTH EAST ¼ OF SECTION 9, TOWNSHIP 39 NORTH, RANGE 14 EAST OF THE THIRD PRINCIPAL MERIDIAN, IN COOK COUNTY, ILLINOIS.

EXHIBIT B

EXISTING ALLEY PARCEL

THAT PART OF BLOCK 7 LYING EAST OF THE EAST LINE OF LOTS 1 THROUGH 9 IN JOHN S. PRUSSING'S SUBDIVISION EXCEPT THEREFROM THAT PART DESCRIBED AS FOLLOWS: THE SOUTH 99 FEET OF THAT PART OF LOTS 18 TO 25, LOT 26 (EXCEPT THE WEST 8 FEET THEREOF), TOGETHER WITH THE 10 FOOT STRIP OF LAND LYING WEST OF AND ADJOINING LOTS 18 TO 22, INCLUSIVE, AND EAST OF AND ADJOINING LOT 23 VACATED BY CITY ORDINANCE PASSED SEPTEMBER 26, 1872, ALL IN JOHN S. PRUSSING'S SUBDIVISION OF BLOCKS 7 AND 10 IN WOLCOTT'S ADDITION TO CHICAGO IN THE EAST HALF OF THE NORTHEAST QUARTER OF SECTION 9, TOWNSHIP 39 NORTH, RANGES 14, EAST OF THE THIRD PRINCIPAL MERIDIAN,

(EXCEPT THE FIRE STATION PARCEL DESCRIBED AS FOLLOWS:

THAT PART OF BLOCK 7 LYING EAST OF THE EAST LINE OF LOTS 1 THROUGH 9 IN SAID BLOCK 7, IN JOHN S. PRUSSING'S SUBDIVISION OF BLOCKS 7 AND 10 IN WOLCOTT'S ADDITION TO CHICAGO IN THE EAST HALF OF THE NORTHEAST QUARTER OF SECTION 9, TOWNSHIP 39 NORTH, RANGES 14, EAST OF THE THIRD PRINCIPAL MERIDIAN, LYING BELOW A HORIZONTAL PLANE HAVING AN ELEVATION OF +64.50 FEET CHICAGO CITY DATUM AND LYING ABOVE A HORIZONTAL PLANE HAVING AN ELEVATION OF +14.00 FEET CHICAGO CITY DATUM AND LYING WITHIN ITS HORIZONTAL BOUNDARY PROJECTED VERTICALLY AND DESCRIBED AS FOLLOWS:

COMMENCING AT THE NORTHWEST CORNER OF BLOCK 7 IN JOHN S. PRUSSING'S SUBDIVISION AFORESAID; THENCE SOUTH 90 DEGREES 00 MINUTES 00 SECONDS EAST ALONG THE NORTH LINE OF SAID BLOCK 7 A DISTANCE OF 109.85 FEET TO THE POINT OF BEGINNING; THENCE SOUTH 90 DEGREES 00 MINUTES 00 SECONDS EAST ALONG THE NORTH LINE OF SAID BLOCK 7 A DISTANCE OF 89.20 FEET; THENCE SOUTH 00 DEGREES 16 MINUTES 14 SECONDS EAST 125.00 FEET; THENCE NORTH 90 DEGREES 00 MINUTES 00 SECONDS WEST 89.10 FEET; THENCE NORTH 00 DEGREES 19 MINUTES 07 SECONDS WEST 125.00 FEET TO THE POINT OF BEGINNING;

TOGETHER WITH

THAT PART OF BLOCK 7 LYING EAST OF THE EAST LINE OF LOTS 1 THROUGH 9 IN SAID BLOCK 7, IN JOHN S. PRUSSING'S SUBDIVISION OF BLOCKS 7 AND 10 IN WOLCOTT'S ADDITION TO CHICAGO IN THE EAST HALF OF THE NORTHEAST QUARTER OF SECTION 9, TOWNSHIP 39 NORTH, RANGES 14, EAST OF THE THIRD PRINCIPAL MERIDIAN, LYING BELOW A HORIZONTAL PLANE HAVING AN ELEVATION OF +14.00 FEET CHICAGO CITY DATUM AND LYING WITHIN ITS HORIZONTAL BOUNDARY PROJECTED VERTICALLY AND DESCRIBED AS FOLLOWS:

COMMENCING AT THE NORTHWEST CORNER OF BLOCK 7 IN JOHN S. PRUSSING'S SUBDIVISION AFORESAID; THENCE SOUTH 90 DEGREES 00 MINUTES 00 SECONDS EAST ALONG THE NORTH LINE OF SAID BLOCK 7 A DISTANCE OF 106.57 FEET TO THE POINT OF BEGINNING; THENCE SOUTH 90 DEGREES 00 MINUTES 00 SECONDS EAST ALONG THE NORTH LINE OF SAID BLOCK 7 A DISTANCE OF 92.48 FEET; THENCE SOUTH 00 DEGREES 16 MINUTES 14 SECONDS EAST 125.00 FEET; THENCE

NORTH 90 DEGREES 00 MINUTES 00 SECONDS WEST 89.10 FEET; THENCE NORTH 00 DEGREES 19 MINUTES 07 SECONDS WEST 19.33 FEET; THENCE NORTH 90 DEGREES 00 MINUTES 00 SECONDS WEST 3.86 FEET; THENCE NORTH 00 DEGREES 00 MINUTES 00 SECONDS EAST 105.67 FEET TO THE POINT OF BEGINNING), ALL IN COOK COUNTY, ILLINOIS.

AREA AT ELEVATION +64.50 CCD = 28,323 SQ. FT. OR 0.65 ACRES MORE OR LESS.

EXHIBIT C

DEVELOPER'S PARCEL

PARCEL 1:

LOTS 1-9, BOTH INCLUSIVE, IN JOHN S. PRUSSING'S SUBDIVISION OF BLOCKS 7 AND 10 IN WOLCOTT'S ADDITION TO CHICAGO OF THE EAST HALF OF THE NORTHEAST QUARTER OF SECTION 9, TOWNSHIP 39 NORTH, RANGE 14, EAST OF THE THIRD PRINCIPAL MERIDIAN, IN COOK COUNTY, ILLINOIS.

CONTAINING 21,826 SQ. FT. OR 0.50 ACRES MORE OR LESS.

PARCEL 2:

THAT PART OF BLOCK 7 LYING EAST OF THE EAST LINE OF LOTS 1 THROUGH 9 IN JOHN S. PRUSSING'S SUBDIVISION EXCEPT THEREFROM THAT PART DESCRIBED AS FOLLOWS: THE SOUTH 99 FEET OF THAT PART OF LOTS 18 TO 25, LOT 26 (EXCEPT THE WEST 8 FEET THEREOF), TOGETHER WITH THE 10 FOOT STRIP OF LAND LYING WEST OF AND ADJOINING LOTS 18 TO 22, INCLUSIVE, AND EAST OF AND ADJOINING LOT 23 VACATED BY CITY ORDINANCE PASSED SEPTEMBER 26, 1872, ALL IN JOHN S. PRUSSING'S SUBDIVISION OF BLOCKS 7 AND 10 IN WOLCOTT'S ADDITION TO CHICAGO IN THE EAST HALF OF THE NORTHEAST QUARTER OF SECTION 9, TOWNSHIP 39 NORTH, RANGES 14, EAST OF THE THIRD PRINCIPAL MERIDIAN, IN COOK COUNTY, ILLINOIS.

CONTAINING 28,323 SQ. FT. OR 0.65 ACRES MORE OR LESS.

PARCEL 3:

THE SOUTH 99 FEET OF THAT PART OF LOTS 18 TO 25, LOT 26 (EXCEPT THE WEST 8 FEET THEREOF), TOGETHER WITH THE 10 FOOT STRIP OF LAND LYING WEST OF AND ADJOINING LOTS 18 TO 22, INCLUSIVE, AND EAST OF AND ADJOINING LOT 23 VACATED BY CITY ORDINANCE PASSED SEPTEMBER 26, 1872, ALL IN BLOCK 7 IN JOHN S. PRUSSING'S SUBDIVISION OF BLOCKS 7 AND 10 IN WOLCOTT'S ADDITION TO CHICAGO IN THE EAST 1/2 OF THE NORTHEAST 1/4 OF SECTION 9, TOWNSHIP 39 NORTH, RANGE 14, EAST OF THE THIRD PRINCIPAL MERIDIAN, IN COOK COUNTY, ILLINOIS.

CONTAINING 20,153 SQ. FT. OR 0.46 ACRES MORE OR LESS.

EXHIBIT D

FIREHOUSE DESIGN DOCUMENTS AND SPECIFICATIONS



ENGINE COMPANY 42 FIRE STATION
Chicago Fire Department

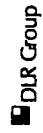
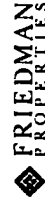
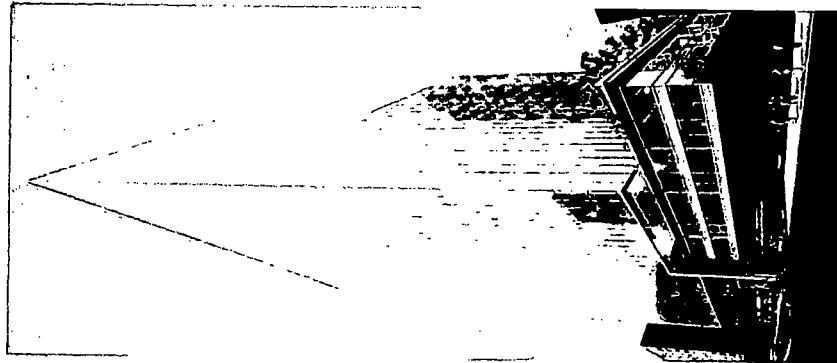

TABLE OF CONTENTS



Team Experience	3
Project Site	4
Project Phasing Plan	5
Floor Plan - Lower Level 2	6
Floor Plan - Lower Level 1	7
Floor Plan - Ground Floor	8
Floor Plan - Level 2	9
Roof Plan	10
Elevations - West Alley & West Illinois St.	11
Elevations - East Well & South Alley	12
East/West Building Section	13
North/South Building Section	14
Architectural Narrative	15-19
Program and Objectives	20
Prototype Plan - For Reference	21
Project Schedule	22
Appendix A:	
Floor Plan - Optional Level 3	23
East/West Building Section - Optional Level 3	24
North/South Building Section - Optional Level 3	25
Appendix B:	
FF&E Matrix	26-29

TEAM EXPERIENCE

Friedman Properties – Developer

DLR Group – Architect

F H Paschen – Construction: Fire Station and optional Fire Prevention Office Build-Out
Lendlease – Construction: Fire Station Shell-and-core and Phase 2 Tower

Friedman Properties

Friedman Properties has been a leading real estate investor and developer in River North since the 1970's. FPL and its partners possess the expertise and capabilities to redevelop the property to its highest and best use and its partners represent best-in-class operators across the restaurant, hospitality, parking and office sectors. The team has the financial resources to successfully complete the proposed redevelopment while maximizing the benefit to the City, Chicago Fire Department, and all other stakeholders. Friedman Properties provides a certainty of transaction execution that will benefit the City and Chicago Fire Department. This development will revitalize the City-owned property that sits on a key site in River North and will be designed such that it optimizes the benefit to the stakeholders of the neighborhood.

DLR Group

DLR Group is the author of the current Chicago Fire Station Prototype Design. Working closely with the Public Building Commission and Chicago Fire Department, DLR Group served as the design architect for the most recently completed new fire station, Engine Company 16. DLR also served as designer and architect-of-record for Engine Company 109 in Little Village and architect-of-record for Engine Company 121.

F H Paschen

Paschen built Engine Company 16, which is Chicago's most recent new fire station. They bring the experience and depth of understanding required to construct this uniquely durable and critically purpose-built public safety facility.

Lendlease

Lendlease brings extensive construction expertise as well as an unmatched track-record for the successful delivery of complex, phased, large-scale projects. They have played an integral role in the positive transformation of the River North neighborhood, engaging with Friedman Properties on the recently completed construction a trio of high-rise hotel projects. Their experience with planning, mobilization, staging and logistics in the vibrant urban context of River North will be a key factor in the success of this project.

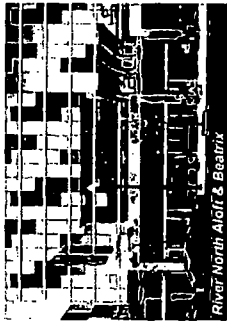

River North Aloft & Beatrix

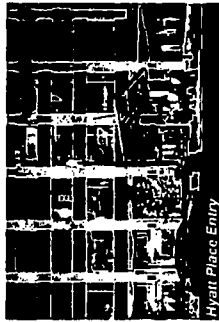

Hyatt Place Entry

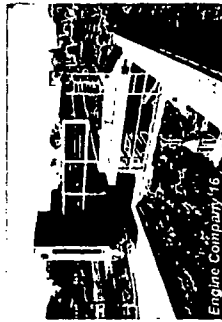

Engine Company 16



Engine Company 109

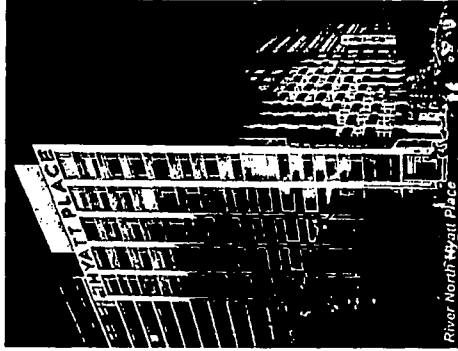

River North Hyatt Place

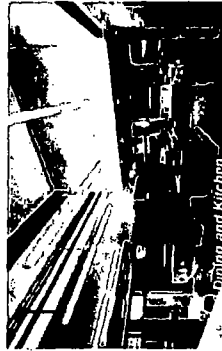

Dining and Kitchen

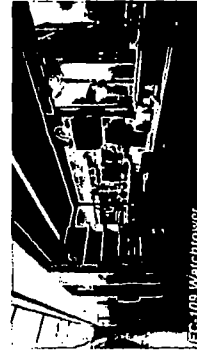

EC-109 Watchtower

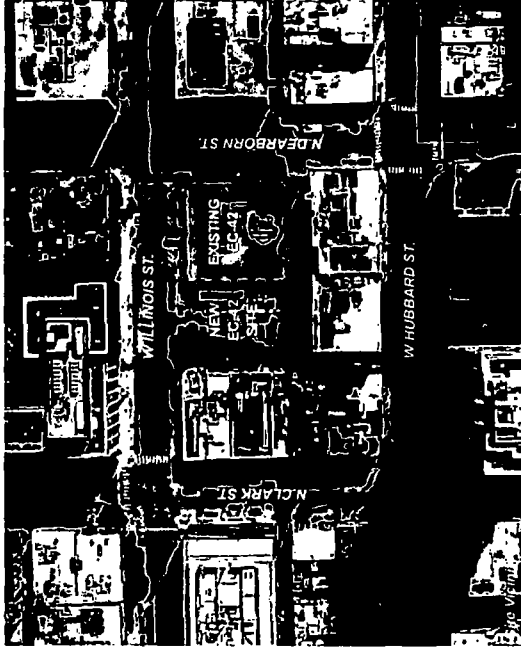
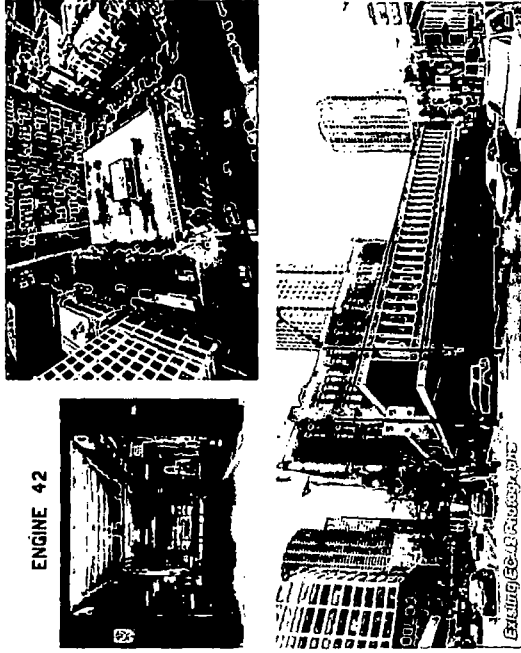

PROJECT SITE

PROJECT PHASING PLAN

- CONSTRUCTION
- ▨ DEMOLITION

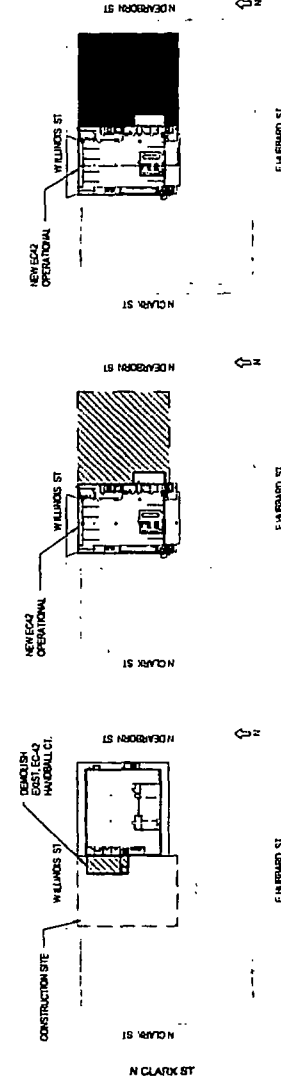
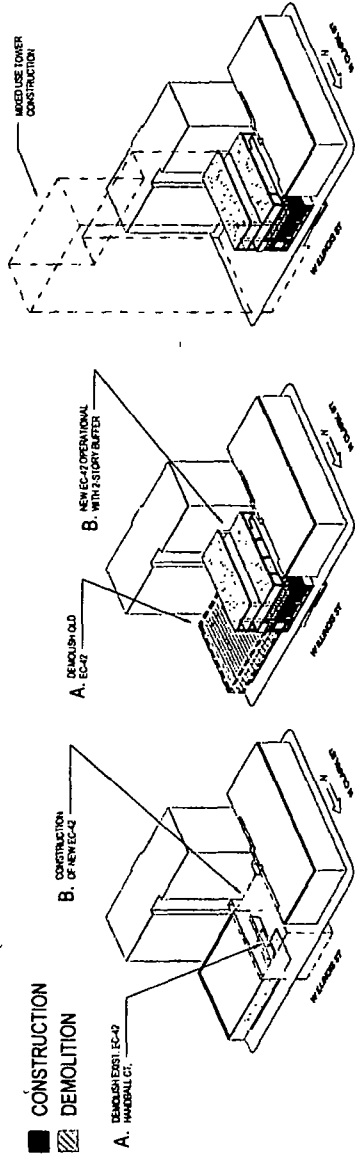

PHASE 1: DEMOLITION OF EXISTING EC-P AND HUBBALL CT, CONSTRUCTION OF NEW EC-A2.

PHASE 2: CONSTRUCTION OF NEW EC-OPERATIONAL BUILDING.

PHASE 3: FINAL STATE WITH NEW EC-OPERATIONAL BUILDING AND VISITOR BUFFER.

FLOOR PLAN - LOWER LEVEL 2

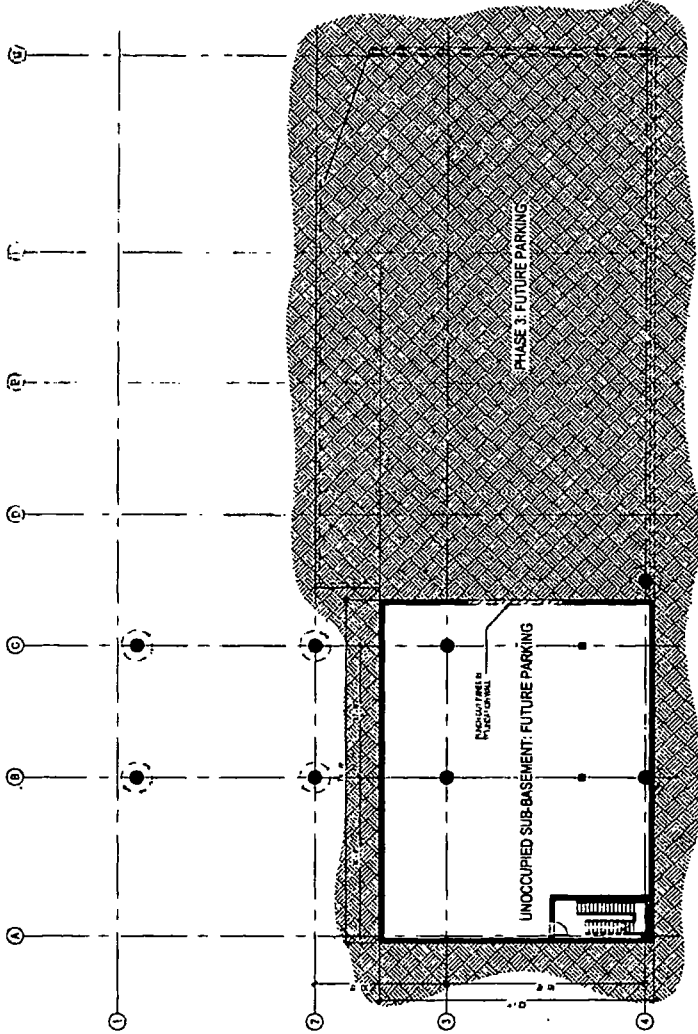

EC-42 FIRE STATION

- 1. FINISH FLOOR
- 2. UNOCCUPIED SUB-BASEMENT
- 3. FINISH FLOOR
- 4. UNOCCUPIED SUB-BASEMENT
- 5. FINISH FLOOR
- 6. UNOCCUPIED SUB-BASEMENT
- 7. FINISH FLOOR
- 8. UNOCCUPIED SUB-BASEMENT
- 9. FINISH FLOOR
- 10. UNOCCUPIED SUB-BASEMENT
- 11. FINISH FLOOR
- 12. UNOCCUPIED SUB-BASEMENT
- 13. FINISH FLOOR
- 14. UNOCCUPIED SUB-BASEMENT
- 15. FINISH FLOOR
- 16. UNOCCUPIED SUB-BASEMENT
- 17. FINISH FLOOR
- 18. UNOCCUPIED SUB-BASEMENT
- 19. FINISH FLOOR
- 20. UNOCCUPIED SUB-BASEMENT
- 21. FINISH FLOOR
- 22. UNOCCUPIED SUB-BASEMENT
- 23. FINISH FLOOR
- 24. UNOCCUPIED SUB-BASEMENT
- 25. FINISH FLOOR
- 26. UNOCCUPIED SUB-BASEMENT
- 27. FINISH FLOOR
- 28. UNOCCUPIED SUB-BASEMENT
- 29. FINISH FLOOR
- 30. UNOCCUPIED SUB-BASEMENT
- 31. FINISH FLOOR
- 32. UNOCCUPIED SUB-BASEMENT
- 33. FINISH FLOOR
- 34. UNOCCUPIED SUB-BASEMENT
- 35. FINISH FLOOR
- 36. UNOCCUPIED SUB-BASEMENT
- 37. FINISH FLOOR
- 38. UNOCCUPIED SUB-BASEMENT
- 39. FINISH FLOOR
- 40. UNOCCUPIED SUB-BASEMENT
- 41. FINISH FLOOR
- 42. UNOCCUPIED SUB-BASEMENT
- 43. FINISH FLOOR
- 44. UNOCCUPIED SUB-BASEMENT
- 45. FINISH FLOOR
- 46. UNOCCUPIED SUB-BASEMENT
- 47. FINISH FLOOR
- 48. UNOCCUPIED SUB-BASEMENT
- 49. FINISH FLOOR
- 50. UNOCCUPIED SUB-BASEMENT
- 51. FINISH FLOOR
- 52. UNOCCUPIED SUB-BASEMENT
- 53. FINISH FLOOR
- 54. UNOCCUPIED SUB-BASEMENT
- 55. FINISH FLOOR
- 56. UNOCCUPIED SUB-BASEMENT
- 57. FINISH FLOOR
- 58. UNOCCUPIED SUB-BASEMENT
- 59. FINISH FLOOR
- 60. UNOCCUPIED SUB-BASEMENT
- 61. FINISH FLOOR
- 62. UNOCCUPIED SUB-BASEMENT
- 63. FINISH FLOOR
- 64. UNOCCUPIED SUB-BASEMENT
- 65. FINISH FLOOR
- 66. UNOCCUPIED SUB-BASEMENT
- 67. FINISH FLOOR
- 68. UNOCCUPIED SUB-BASEMENT
- 69. FINISH FLOOR
- 70. UNOCCUPIED SUB-BASEMENT
- 71. FINISH FLOOR
- 72. UNOCCUPIED SUB-BASEMENT
- 73. FINISH FLOOR
- 74. UNOCCUPIED SUB-BASEMENT
- 75. FINISH FLOOR
- 76. UNOCCUPIED SUB-BASEMENT
- 77. FINISH FLOOR
- 78. UNOCCUPIED SUB-BASEMENT
- 79. FINISH FLOOR
- 80. UNOCCUPIED SUB-BASEMENT
- 81. FINISH FLOOR
- 82. UNOCCUPIED SUB-BASEMENT
- 83. FINISH FLOOR
- 84. UNOCCUPIED SUB-BASEMENT
- 85. FINISH FLOOR
- 86. UNOCCUPIED SUB-BASEMENT
- 87. FINISH FLOOR
- 88. UNOCCUPIED SUB-BASEMENT
- 89. FINISH FLOOR
- 90. UNOCCUPIED SUB-BASEMENT
- 91. FINISH FLOOR
- 92. UNOCCUPIED SUB-BASEMENT
- 93. FINISH FLOOR
- 94. UNOCCUPIED SUB-BASEMENT
- 95. FINISH FLOOR
- 96. UNOCCUPIED SUB-BASEMENT
- 97. FINISH FLOOR
- 98. UNOCCUPIED SUB-BASEMENT
- 99. FINISH FLOOR
- 100. UNOCCUPIED SUB-BASEMENT

MULTI-GAS RATIO BOUND	
LINE	AREA
LINE 1	5000
LINE 2	1000
LINE 3	1000
LINE 4	1000
LINE 5	1000
LINE 6	1000
LINE 7	1000
LINE 8	1000
LINE 9	1000
LINE 10	1000
LINE 11	1000
LINE 12	1000
LINE 13	1000
LINE 14	1000
LINE 15	1000
LINE 16	1000
LINE 17	1000
LINE 18	1000
LINE 19	1000
LINE 20	1000
LINE 21	1000
LINE 22	1000
LINE 23	1000
LINE 24	1000
LINE 25	1000
LINE 26	1000
LINE 27	1000
LINE 28	1000
LINE 29	1000
LINE 30	1000
LINE 31	1000
LINE 32	1000
LINE 33	1000
LINE 34	1000
LINE 35	1000
LINE 36	1000
LINE 37	1000
LINE 38	1000
LINE 39	1000
LINE 40	1000
LINE 41	1000
LINE 42	1000
LINE 43	1000
LINE 44	1000
LINE 45	1000
LINE 46	1000
LINE 47	1000
LINE 48	1000
LINE 49	1000
LINE 50	1000

FLOOR PLAN - GROUND FLOOR

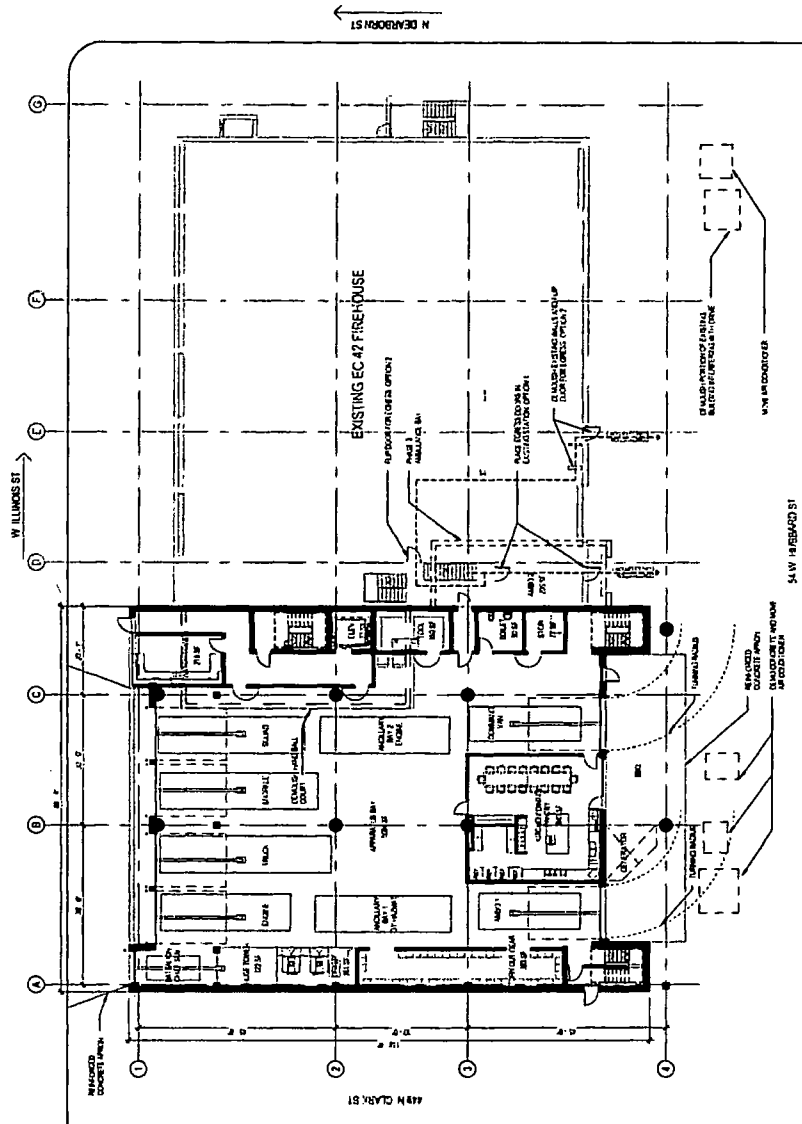

MEASUREMENT	AREA
LEVEL 1	1,000 SF
LEVEL 2	1,000 SF
LEVEL 3	1,000 SF
TOTAL	3,000 SF
PER LEVEL 1	1,000 SF
PER LEVEL 2	1,000 SF
PER LEVEL 3	1,000 SF

EC-42 FIRE STATION

- 1. EXISTING CONCRETE MAIN FLOOR SLAB
- 2. EXISTING CONCRETE FLOOR SLAB
- 3. EXISTING CONCRETE FLOOR SLAB
- 4. EXISTING CONCRETE FLOOR SLAB
- 5. EXISTING CONCRETE FLOOR SLAB
- 6. EXISTING CONCRETE FLOOR SLAB
- 7. EXISTING CONCRETE FLOOR SLAB
- 8. EXISTING CONCRETE FLOOR SLAB
- 9. EXISTING CONCRETE FLOOR SLAB
- 10. EXISTING CONCRETE FLOOR SLAB
- 11. EXISTING CONCRETE FLOOR SLAB
- 12. EXISTING CONCRETE FLOOR SLAB
- 13. EXISTING CONCRETE FLOOR SLAB
- 14. EXISTING CONCRETE FLOOR SLAB
- 15. EXISTING CONCRETE FLOOR SLAB
- 16. EXISTING CONCRETE FLOOR SLAB
- 17. EXISTING CONCRETE FLOOR SLAB
- 18. EXISTING CONCRETE FLOOR SLAB
- 19. EXISTING CONCRETE FLOOR SLAB
- 20. EXISTING CONCRETE FLOOR SLAB

FLOOR PLAN - LEVEL 2

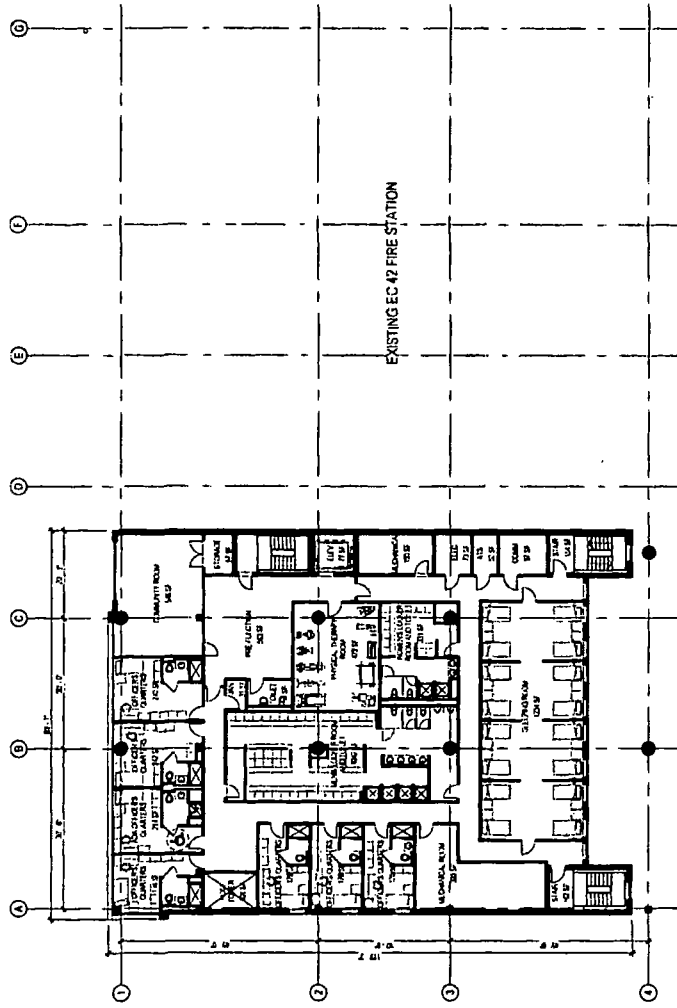

EXISTING EC 42 FIRE STATION

EC-42 FIRE STATION

- 1. FLOOR FINISH
- 2. PARTITION WALL
- 3. PARTITION METAL PANEL SYSTEM
- 4. PARTITION GLASS SYSTEM
- 5. ALUMINUM PARTITION WALL SYSTEM
- 6. PARTITION GLASS SYSTEM
- 7. EXTERIOR FINISH
- 8. EXTERIOR WALL FINISH
- 9. CEILING FINISH
- 10. EXTERIOR WALL FINISH
- 11. EXTERIOR WALL FINISH
- 12. EXTERIOR WALL FINISH
- 13. EXTERIOR WALL FINISH
- 14. EXTERIOR WALL FINISH
- 15. EXTERIOR WALL FINISH
- 16. EXTERIOR WALL FINISH
- 17. EXTERIOR WALL FINISH
- 18. EXTERIOR WALL FINISH
- 19. EXTERIOR WALL FINISH
- 20. EXTERIOR WALL FINISH
- 21. EXTERIOR WALL FINISH
- 22. EXTERIOR WALL FINISH
- 23. EXTERIOR WALL FINISH
- 24. EXTERIOR WALL FINISH
- 25. EXTERIOR WALL FINISH
- 26. EXTERIOR WALL FINISH
- 27. EXTERIOR WALL FINISH
- 28. EXTERIOR WALL FINISH
- 29. EXTERIOR WALL FINISH
- 30. EXTERIOR WALL FINISH
- 31. EXTERIOR WALL FINISH
- 32. EXTERIOR WALL FINISH
- 33. EXTERIOR WALL FINISH
- 34. EXTERIOR WALL FINISH
- 35. EXTERIOR WALL FINISH
- 36. EXTERIOR WALL FINISH
- 37. EXTERIOR WALL FINISH
- 38. EXTERIOR WALL FINISH
- 39. EXTERIOR WALL FINISH
- 40. EXTERIOR WALL FINISH
- 41. EXTERIOR WALL FINISH
- 42. EXTERIOR WALL FINISH
- 43. EXTERIOR WALL FINISH
- 44. EXTERIOR WALL FINISH
- 45. EXTERIOR WALL FINISH
- 46. EXTERIOR WALL FINISH
- 47. EXTERIOR WALL FINISH
- 48. EXTERIOR WALL FINISH
- 49. EXTERIOR WALL FINISH
- 50. EXTERIOR WALL FINISH

REVISIONS	
NO.	DESCRIPTION
1	ISSUED FOR PERMITS
2	ISSUED FOR PERMITS
3	ISSUED FOR PERMITS
4	ISSUED FOR PERMITS
5	ISSUED FOR PERMITS
6	ISSUED FOR PERMITS
7	ISSUED FOR PERMITS
8	ISSUED FOR PERMITS
9	ISSUED FOR PERMITS
10	ISSUED FOR PERMITS
11	ISSUED FOR PERMITS
12	ISSUED FOR PERMITS
13	ISSUED FOR PERMITS
14	ISSUED FOR PERMITS
15	ISSUED FOR PERMITS
16	ISSUED FOR PERMITS
17	ISSUED FOR PERMITS
18	ISSUED FOR PERMITS
19	ISSUED FOR PERMITS
20	ISSUED FOR PERMITS
21	ISSUED FOR PERMITS
22	ISSUED FOR PERMITS
23	ISSUED FOR PERMITS
24	ISSUED FOR PERMITS
25	ISSUED FOR PERMITS
26	ISSUED FOR PERMITS
27	ISSUED FOR PERMITS
28	ISSUED FOR PERMITS
29	ISSUED FOR PERMITS
30	ISSUED FOR PERMITS
31	ISSUED FOR PERMITS
32	ISSUED FOR PERMITS
33	ISSUED FOR PERMITS
34	ISSUED FOR PERMITS
35	ISSUED FOR PERMITS
36	ISSUED FOR PERMITS
37	ISSUED FOR PERMITS
38	ISSUED FOR PERMITS
39	ISSUED FOR PERMITS
40	ISSUED FOR PERMITS
41	ISSUED FOR PERMITS
42	ISSUED FOR PERMITS
43	ISSUED FOR PERMITS
44	ISSUED FOR PERMITS
45	ISSUED FOR PERMITS
46	ISSUED FOR PERMITS
47	ISSUED FOR PERMITS
48	ISSUED FOR PERMITS
49	ISSUED FOR PERMITS
50	ISSUED FOR PERMITS

ELEVATIONS - WEST ALLEY AND W ILLINOIS ST.

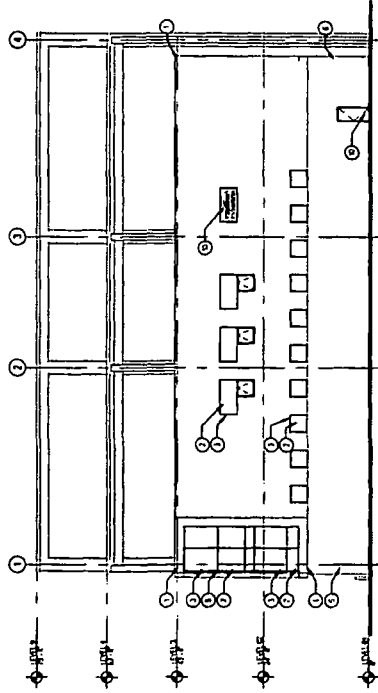

WEST ALLEY ELEVATION

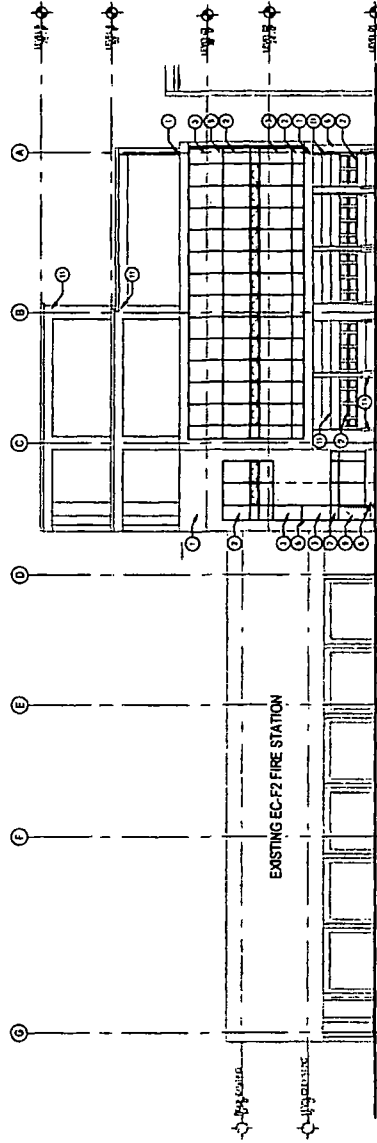

W. ILLINOIS ST. ELEVATION

EC-42 FIRE STATION

- LEGEND**
1. MATERIAL COMPATIBLE WITH FINISH SYSTEM
 2. FINISH SYSTEM
 3. FINISH SYSTEM
 4. ALUMINUM CLAD PANEL SYSTEM
 5. ALUMINUM CLAD PANEL SYSTEM
 6. ALUMINUM CLAD PANEL SYSTEM
 7. ALUMINUM CLAD PANEL SYSTEM
 8. ALUMINUM CLAD PANEL SYSTEM
 9. ALUMINUM CLAD PANEL SYSTEM
 10. ALUMINUM CLAD PANEL SYSTEM
 11. ALUMINUM CLAD PANEL SYSTEM
 12. ALUMINUM CLAD PANEL SYSTEM
 13. ALUMINUM CLAD PANEL SYSTEM
 14. ALUMINUM CLAD PANEL SYSTEM
 15. ALUMINUM CLAD PANEL SYSTEM
 16. ALUMINUM CLAD PANEL SYSTEM
 17. ALUMINUM CLAD PANEL SYSTEM
 18. ALUMINUM CLAD PANEL SYSTEM
 19. ALUMINUM CLAD PANEL SYSTEM
 20. ALUMINUM CLAD PANEL SYSTEM

NEW EXISTING	
1	2
3	4
5	6
7	8
9	10
11	12
13	14
15	16
17	18
19	20

ELEVATIONS - EAST WALL AND SOUTH ALLEY

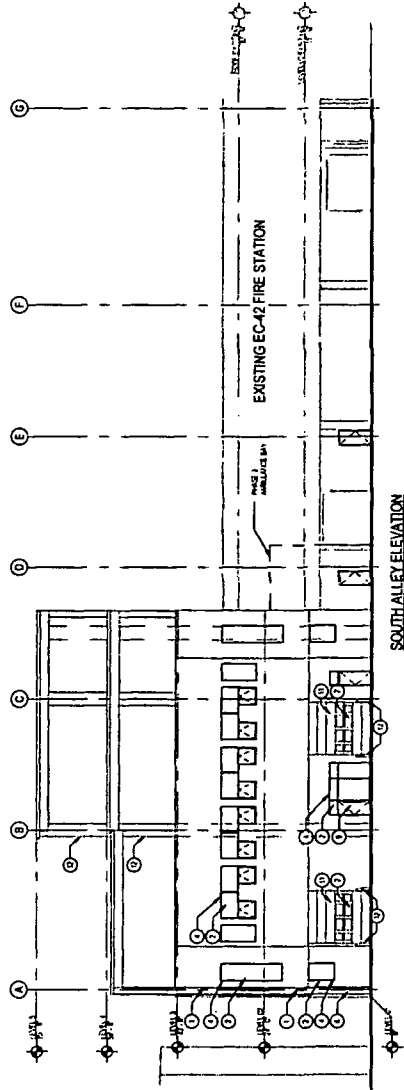
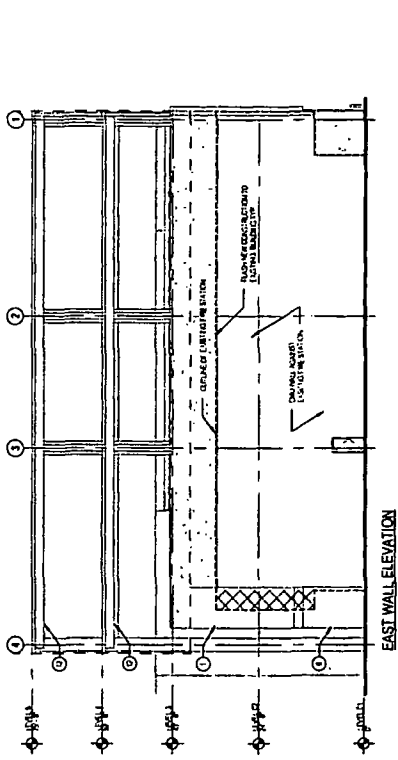

EC-42 FIRE STATION

- REVISIONS**
1. ALL DIMENSIONS IN FEET & INCHES
 2. ALL DIMENSIONS TO FACE UNLESS NOTED OTHERWISE
 3. ALL DIMENSIONS TO FACE UNLESS NOTED OTHERWISE
 4. ALL DIMENSIONS TO FACE UNLESS NOTED OTHERWISE
 5. ALL DIMENSIONS TO FACE UNLESS NOTED OTHERWISE
 6. ALL DIMENSIONS TO FACE UNLESS NOTED OTHERWISE
 7. ALL DIMENSIONS TO FACE UNLESS NOTED OTHERWISE
 8. ALL DIMENSIONS TO FACE UNLESS NOTED OTHERWISE
 9. ALL DIMENSIONS TO FACE UNLESS NOTED OTHERWISE
 10. ALL DIMENSIONS TO FACE UNLESS NOTED OTHERWISE
 11. ALL DIMENSIONS TO FACE UNLESS NOTED OTHERWISE
 12. ALL DIMENSIONS TO FACE UNLESS NOTED OTHERWISE
 13. ALL DIMENSIONS TO FACE UNLESS NOTED OTHERWISE
 14. ALL DIMENSIONS TO FACE UNLESS NOTED OTHERWISE
 15. ALL DIMENSIONS TO FACE UNLESS NOTED OTHERWISE
 16. ALL DIMENSIONS TO FACE UNLESS NOTED OTHERWISE
 17. ALL DIMENSIONS TO FACE UNLESS NOTED OTHERWISE
 18. ALL DIMENSIONS TO FACE UNLESS NOTED OTHERWISE
 19. ALL DIMENSIONS TO FACE UNLESS NOTED OTHERWISE
 20. ALL DIMENSIONS TO FACE UNLESS NOTED OTHERWISE

NO.	DESCRIPTION	DATE	BY	CHECKED
1	ISSUED FOR PERMITS	05/20/22	JL	JL
2	ISSUED FOR PERMITS	05/20/22	JL	JL
3	ISSUED FOR PERMITS	05/20/22	JL	JL
4	ISSUED FOR PERMITS	05/20/22	JL	JL
5	ISSUED FOR PERMITS	05/20/22	JL	JL
6	ISSUED FOR PERMITS	05/20/22	JL	JL
7	ISSUED FOR PERMITS	05/20/22	JL	JL
8	ISSUED FOR PERMITS	05/20/22	JL	JL
9	ISSUED FOR PERMITS	05/20/22	JL	JL
10	ISSUED FOR PERMITS	05/20/22	JL	JL
11	ISSUED FOR PERMITS	05/20/22	JL	JL
12	ISSUED FOR PERMITS	05/20/22	JL	JL
13	ISSUED FOR PERMITS	05/20/22	JL	JL
14	ISSUED FOR PERMITS	05/20/22	JL	JL
15	ISSUED FOR PERMITS	05/20/22	JL	JL
16	ISSUED FOR PERMITS	05/20/22	JL	JL
17	ISSUED FOR PERMITS	05/20/22	JL	JL
18	ISSUED FOR PERMITS	05/20/22	JL	JL
19	ISSUED FOR PERMITS	05/20/22	JL	JL
20	ISSUED FOR PERMITS	05/20/22	JL	JL

NORTH/SOUTH SECTION

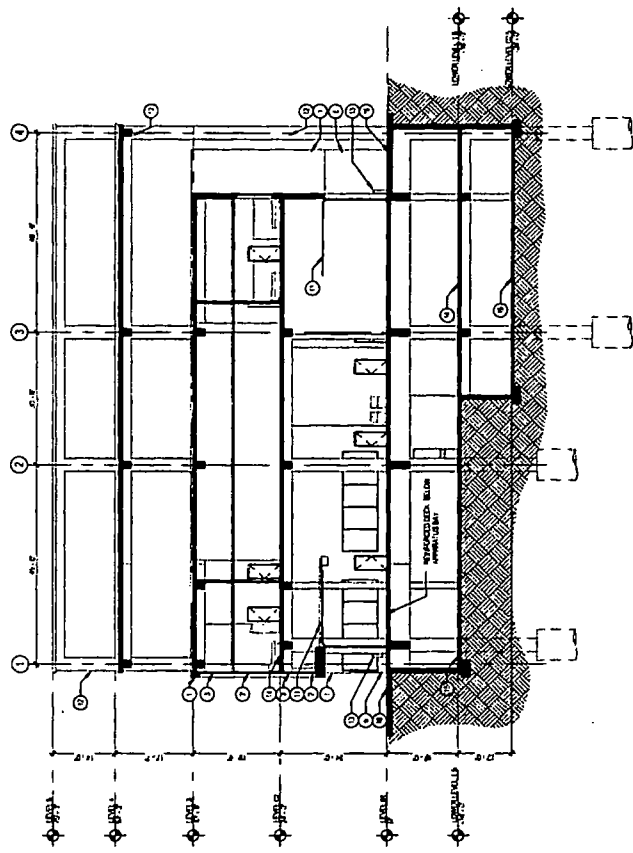

EC-42 FIRE STATION

- LEGEND**
- 1. CONCRETE
 - 2. INSULATION
 - 3. GYPSUM BOARD
 - 4. METAL STUDS
 - 5. ALUMINUM CLADDING SYSTEM
 - 6. CONCRETE
 - 7. CONCRETE
 - 8. CONCRETE
 - 9. CONCRETE
 - 10. CONCRETE
 - 11. CONCRETE
 - 12. CONCRETE
 - 13. CONCRETE
 - 14. CONCRETE
 - 15. CONCRETE
 - 16. CONCRETE
 - 17. CONCRETE
 - 18. CONCRETE
 - 19. CONCRETE
 - 20. CONCRETE

NO.	DESCRIPTION	QTY	UNIT
1	CONCRETE	100	CU YD
2	INSULATION	50	CU YD
3	GYPSUM BOARD	200	SQ YD
4	METAL STUDS	100	LINEAL FT
5	ALUMINUM CLADDING SYSTEM	100	SQ YD
6	CONCRETE	100	CU YD
7	CONCRETE	100	CU YD
8	CONCRETE	100	CU YD
9	CONCRETE	100	CU YD
10	CONCRETE	100	CU YD
11	CONCRETE	100	CU YD
12	CONCRETE	100	CU YD
13	CONCRETE	100	CU YD
14	CONCRETE	100	CU YD
15	CONCRETE	100	CU YD
16	CONCRETE	100	CU YD
17	CONCRETE	100	CU YD
18	CONCRETE	100	CU YD
19	CONCRETE	100	CU YD
20	CONCRETE	100	CU YD

ARCHITECTURAL DESIGN NARRATIVE

1. Project Description

- a. The project is a new, phased mixed-use development in the City of Chicago at the intersection of N Dearborn Street and W Illinois Street. The project includes construction of a new building, the renovation of the old fire station, and the construction of a new, multi-story high-rise building. The new fire station will be located on the east side of the City and will be a major development in the downtown Chicago setting. To accommodate size constraints and future fire station expansion, the fire station program is stacked vertically on the site, with a ground-level high-rise building above it. Core values, important to the City, end users, and operators of the facility, will remain a key component of the development for the fire station and include longevity, resiliency, low-maintenance systems/materials, sustainability, and responsible lifecycle costs for the building materials and systems. Also critical to the success of the project is zero interruptions to the ongoing operations of the existing fire station on the site.
- b. The fire station program for this building has three main components: the Apparatus Room with support spaces, the main fire house, and parking. An optional accommodation for offices for Fire Prevention Bureau is provided for consideration. Parking is located on the lower levels. Access to the lower levels is available via a ramp off N Dearborn Street that is part of the subsequent construction phases, after the fire station is complete. The ground level for the fire station contains the Apparatus Room with two full, pull-thru bays, two partial bays, and two additional, partial bays dedicated for the Battalion Chief and additional ambulance. Other program areas at this level include the hose tower, turn-out gear room, tool room, storage room, kitchen, dining, pantry, and additional support areas. The second level includes living spaces, consisting of a community/training room, sleeping areas for seven officers and 16 full-time personnel, locker rooms, a physical training room and all the necessary support spaces. The optional third level includes all functions for the Fire Prevention Bureau and consists of a reception area, six private offices, a large open office area, small conference room, large conference room, kitchenette, and support spaces.
- c. The design team anticipates the City requirement to achieve a minimum of LEED Silver Certification under USGBC's current LEED building rating system.
- d. Materials, requirements and standards included below are minimum standards required to be provided by the General Contractor. Some products will be sole sourced as requested by the City of Chicago, due to performance criteria or service contracts already in place with the City of Chicago. No substitutions will be allowed on products where noted and further clarification will be provided in the project specifications as the project is developed. The General Contractor will be required to provide all necessary resources, materials, labor, and construction activity to provide a complete project including the accommodation of FF&E for the project.

2. Codes and Standards

- a. All work shall comply with the Chicago Building Code (current edition), NFPA 101 Life Safety Code v2000, Illinois Accessibility Code, Illinois Plumbing Code, International Energy Conservation Code v2015, with any amendments and any other codes and ordinances adopted by the City of Chicago.
- b. The following industry standards shall be used as guidelines for design.
 - i. Basis of Design Materials:
 - a. Face Brick
 - i. Endcott Clay, Manganesse Ironspot, Smooth Modular
 - b. BCMU:
 - i. Tremwyth Verastone Plus (3 colors)
 - c. Aluminum Composite Metal Panels:
 - i. Alucobond Aluminum Composite Panels; Route and Return

- i. National Fire Protection Association (NFPA).
- ii. Americans with Disabilities Act (ADA).

3. Exterior Building Systems

a. Building Performance Goals

- i. Provide a high-performing, exterior wall system that is attractive, energy efficient and responsive to the environment. The wall system includes internally-broken, glazed systems with low-e coated, insulated glass. Care should be taken to eliminate thermal bridging throughout the building and achieve an air and water tight building enclosure.
- ii. The roof of the building should be properly insulated to optimize the required mechanical systems and meet energy code requirements.
- iii. The design will take advantage of natural daylighting wherever possible to minimize and eliminate the need for artificial lighting.
- iv. The lighting system on the project will use energy-efficient, LED fixtures that can be controlled in zones as well as with occupancy sensors. In areas where desk work will be performed task lighting will be provided to keep ambient lighting levels low to save energy use.
- v. Exterior site lighting will be designed to create zero light spill.

b. Building Envelope

- i. At the ground level of the building the exterior walls are masonry cavity wall construction that is reinforced horizontally and vertically. This wall type consists of grout-filled and filled concrete block with a fluid-applied air barrier, cavity wall insulation with integral drainage layer and modular face brick in a running bond pattern to a height of 8'-0" on the street facade. Above 8'-0" AFF at the street facade, the wall system changes from the face brick veneer to a concealed fastener, dry-seal, aluminum, composite metal panel system.

i. Basis of Design Materials:

- a. Face Brick
 - i. Endcott Clay, Manganesse Ironspot, Smooth Modular
- b. BCMU:
 - i. Tremwyth Verastone Plus (3 colors)
- c. Aluminum Composite Metal Panels:
 - i. Alucobond Aluminum Composite Panels; Route and Return

ARCHITECTURAL DESIGN NARRATIVE

- v Concrete structural stoops are included outside all doors at grade level.
 - vi The roof is high albedo TPO roof system with polyisocyanurate board roof insulation and tapered insulation to create positive drainage
 - 1 Basis of Design Materials
 - a Roofing
 - i GAF - EverGuard 60 mil membrane
 - ii R-30 roof insulation
 - b Warranty
 - i 20 years
 - vi Exterior trim/fascia is achieved with a concealed fastener, dry-seal, aluminum, composite metal panel system
 - 1 Basis of Design Materials:
 - a Alucobond Aluminum Composite Panels, Route and Return Dry Seal System
 - b Aluminum Finishes:
 - i High-performance, three-coat fluoropolymer, metallic/mica finish
- 4 Interior Building Systems
 - a Apparatus Room
 - i The floor slab of the Apparatus Room is a cast-in-place concrete floor slab with double-end rebar reinforcing. Thickness of the slab is determined at this time and will need further structural analysis to determine. The concrete slab in the apparatus room is coated with an industrial epoxy system with an integral cure base.
 - 1. Basis of Design Materials:
 - a. Flooring:
 - i. Crown Polymers CrownShield
 - 1) Integral floor striping as part of system
 - b. Vertical Transportation
 - i. Stairs in the building are flat-pan, steel plate stairs with epoxy terrazzo treads, with integral epoxy abrasives at the nosings
 - 1. Basis of Design Materials.
 - a. Tectura Epoxy Flat Treads
- ii At the ground level entry of the building, the glazing system is a coated aluminum, thermally-broken, storefront system to a height of 8'-0". Doors are wide-stile, heavy-duty rated and fully-glazed with 1" low-E coated, insulated units. At the second and third levels on the north facade of the building, the glazing systems is a coated aluminum, thermally-broken, curtain wall system with awning-style operable vents to meet the Chicago Building Code's light and ventilation requirements. Glazing will be 1" low-E coated, insulated units. Where privacy or spandrel panels are required in the glazing systems, a simulated sandblast ceramic frit is utilized. Punched openings on the west and south facades of the second and third levels are a coated aluminum, thermally-broken, storefront system.
 - 1. Basis of Design Materials.
 - a. Curtain Wall:
 - i. Oldcastle Reliance Curtain Wall System
 - 1) Vents - part of same system
 - b. Storefront
 - i. Oldcastle Series 3000
 - 1) Vents - part of same Series 3000 system
 - 2) Entrances - Oldcastle Thermal Clad Door/Frame
 - c. Glazing
 - i. Viracon VE1-2M
 - d. Aluminum Finishes:
 - i. High-performance, three-coat fluoropolymer, metallic/mica finish
- iii All exterior service type doors and frames are extra heavy duty, thermally-broken, painted, hollow metal
- iv Overhead doors at the apparatus bay are insulated doors with windows as fabricated and installed by Builder Chicago. The door operators shall be tied into the building's backup power system and also have a manual override and chain-fall operator in the event of power or door operator failure.

ARCHITECTURAL DESIGN NARRATIVE

- ii. The Hose Tower stair is a galvanized steel, with 2" thick serrated, metal grate treads
 - iii. The elevator is a machine room-less traction elevator sized to accept a gurney.
 - i. Basis of Design Materials
 - a. Thyssen Krupp Synergy MRL
 - i. Stainless steel finishes and LED lighting
 - c. Interior Walls.
 - i. All interior walls are burnished concrete masonry units (BCMU) with high recycled content. All walls are required to extend to structure above with BCMU where exposed, and standard CMU or metal studs and GWB where concealed above ceilings.
 - i. Basis of Design Materials:
 - a. BCMU.
 - i. Trexwyth Verastone Plus
 - d. General interior finishes applicable to all areas:
 - i. The general floor finish is field-installed epoxy terrazzo flooring (4 colors with basic patterning)
 - i. Basis of Design Materials
 - a. Epoxy Terrazzo:
 - i. Dev-O-Tex Epoxy Terrazzo system
 - ii. Acoustic panel ceilings are a 2 x 2, mineral fiber panel with a regular edge and a minimum 75 NRC.
 - i. Basis of Design Materials:
 - a. Armstrong Ultrana High NRC acoustical panels
 - b. Armstrong Suprafine XL 9/16" suspension system
 - iii. Doors in the building are a mix between flush wood doors with hollow metal frames, stainless steel doors and frames, and hollow metal doors and frames. Locations are as noted below.
 - i. Basis of Design Materials:
 - a. Hollow Metal Doors/Frames: Curries
 - i. Locations: Mechanical rooms, back-of-house spaces, lower level spaces, storage rooms, etc., Toilet Rooms, Locker Rooms
 - b. Stainless Steel Doors/Frames: Curries
 - i. Lyon
- e. Watch Tower
 - i. Countertops are solid surface (2 levels) with integrated monitors and switching for security cameras, control of the systems in the Apparatus Room, site lighting, and front door entry access. The area will include all the dispatch equipment for the Chicago Fire Department, provided by the City. Built-in, recessed display cases are adjacent to this area near the entry.
 - i. Basis of Design Materials:
 - a. Countertops: Corian
 - b. Display Cases: Claridge
- f. Kitchen and Dining
 - i. Ceilings in this area are painted gypsum board. The kitchen area will contain commercial-grade, stainless steel wall cabinets, base cabinets, and countertops, stainless steel appliances, and a commercial cooking hood with fire suppression.
 - i. Basis of Design Materials:
 - a. Kitchen Cabinets: Kevauwe Scientific
- g. Locker and Toilet Rooms
 - i. The flooring in all locker and toilet rooms is epoxy resin. Ceilings are gypsum board in the toilet room / wet areas and acoustical panel ceilings in the locker areas. Ceilings in the shower areas are direct applied, acrylic plaster. Toilet partitions are floor-mounted, overhead-braced, stainless steel partitions. All countertops are stainless steel with integral sinks. Lockers are fully-welded, 24"x21" in dimension, full height deluxe club style metal lockers on a BCMU base and a hardwood bench with a transparent finish. All toilet and shower accessories are stainless steel.
 - i. Basis of Design Materials:
 - a. Epoxy resin flooring:
 - i. Dev-O-Tex
 - b. Toilet partitions:
 - i. Brodley
 - c. Lockers:
 - i. Lyon



ARCHITECTURAL DESIGN NARRATIVE

- d. Toilet and shower accessories:
 - i. Bobrick
- e. Ceramic Tile:
 - i. Dot-Tile - 4"x8" glazed accent tile
 - ii. Epoxy Grout
 - iii. Schluter Systems stainless steel trim at full exposed tile edges, inside and outside corners
- f. Physical Training
 - i. Flooring is a solid rubber tile sports floor. One side of the room will have full-length wall mirrors
 - 1. Basis of Design Materials:
 - a. Flooring:
 - i. ECOsurfaces- ECOfit Recycled Rubber Flooring by ECOPE Commercial Flooring
 - ii. Communications Room, Electrical Room and Mechanical Room shall have exposed CMU walls, no base, clear sealed concrete floors, and exposed ceiling construction (unpainted). Janitor's closet(s) will have FRP wall panels around mop basins.
 - 2. Window Treatments
 - i. In the majority of the building there are manually-operated shades, except for the training room, where the shades are motorized and tied into the AV equipment system. All shades contain 2" daylight shade material, and the training area and sleeping rooms additionally contain blackout shades.
 - 1. Basis of Design Materials
 - a. Shades:
 - i. Mechoshade Mechos5 & DoubleShades
- 5. Signage, Furniture, Fixtures and Equipment
 - a. Signage for the building consists of code-required room identification signage, stainless-steel pin-mounted, LED-backlit, channel letters for exterior building signage, and some vinyl lettering at entry/egress doors. Directional and post/panel signage will be distributed around the building and site for wayfinding, parking signage, etc.
 - b. Loose furniture and equipment in the building includes, but is not limited to, the following:
 - i. System furniture, ergonomic rolling chairs, filing cabinets, beds, bed frames, and bed side tables in all of the Officer's Quarters.
 - ii. The beds, bed frames, and bed side tables in the Sleeping Rooms
 - iii. All stainless steel kitchen appliances and equipment.
- d. Dining tables and chairs in the Dining Area
- v. A built-in, stainless steel gas grill and outdoor furniture at the outdoor Patio area.
- vi. Smartboard system, wall-mounted flat panel televisions, sofas, tables and chairs and 20 individual chairs w/ arm tables.
- vii. The Watch Tower will require 3 ergonomic rolling chairs, under counter filing cabinets, a heavy board tray, small flat panel television, as well as miscellaneous office organizational equipment.
- viii. Physical Training equipment including a treadmill, cross-trainer, recumbent bike, a stair machine, bench press, weight tree and full set of weights, dumbbells and rack, smith machine, wall mounted televisions, etc.
- ix. System furniture, ergonomic rolling chairs, filing cabinets, keyboard trays and miscellaneous office organization equipment in the private and open office areas
- x. The conference rooms will require a Smartboard system, conference table and chairs.
- xi. Free standing storage systems for the storage rooms
 - 1. Basis of Design Materials:
 - a. Gorilla Racks
 - i. The equipment in the Apparatus bay includes:
 - 1. Gear drying cabinets (2).
 - 2. Basis of Design Materials:
 - a. Circu-Air Corp
 - ii. Turn-out gear storage wall mounted rack system and hose storage rack
 - 1. Basis of Design Materials
 - a. Gear Grid System.
 - iii. Gas fire tubular infrared heating system
 - 1. Basis of Design Materials:
 - a. Reznor. (3 per bay)
 - iv. Vehicle exhaust extraction system
 - 1. Basis of Design Materials:
 - a. Phymovent. Provide separate lines between bays with 2 extractors per line
 - v. Personnel Lift
 - 1. Basis of Design Materials:
 - a. JLG Industries, Inc. - Vertical Mast Push Around JLG-20AM

ARCHITECTURAL DESIGN NARRATIVE

6. Miscellaneous system considerations

- a. At this concept stage of the project, there are a variety of systems specific to additional disciplines that require further development to fully understand details. DLR Group has outlined several items below that require consideration and inclusion in pricing activities:
 - i. The project in full will be classified as a "high rise" building. While the design team will work to separate the fire station as much as possible, several accommodations may be required in the design, including fire separations, smoke control, tie-ins to fire command rooms, etc.
 - ii. The project will require tie-ins to OEMC's communication infrastructure for the City. In past projects, communication towers were provided. Due to the unique nature and setting of this project, provisions may be needed at interim phases, and ultimately on the roof of the high-rise building.
 - iii. The last fire station prototypes for the City had sprinkler systems in the fire stations, and we believe it will be required for this building, esp. given the uniqueness and stacking of the program spaces.
 - iv. Sidewalks, pathways, and landscape will be required to meet City ordinances.
 - v. The alley access at the south side of the building will require more than a traditional "alley pavement" due to the size and weight of vehicles coming into the station. The design team believes this area should include concrete pavement at minimum, reinforced to loading standards for fire station apparatus.
 - vi. Coordination and traffic signaling solutions/infrastructure will be required and tied into the fire station watchtower emergency response system.
 - vii. Radio repeaters and cell phone boosters are required throughout the internal fire station at all levels.
 - viii. See Appendix #2 for an example FFBE matrix from the past prototype. All FFBE systems will require further development, verification of manufacturers, and availability.

PROGRAM AND OBJECTIVES

Collaborating with the Chicago Fire Department and DLR Group, creators of the current Chicago firehouse prototype, the team has composed a thoughtful design solution to meet every program requirement.

Training Room Combined with the Community and Day Room functions per the current CFD Prototype.	COMPLETE
Community Room Combined with the Training and Day Room functions per the current CFD Prototype	COMPLETE
Eight (8) apparatus doors The apparatus bay doors have been arranged on 15 centers with 14 wide doors per the current CFD Prototype. In addition to the eight doors, the design accommodates two ancillary bays for an additional Engine and a large (31') Hazmat Rig.	COMPLETE
Male dorm Combined with female dorm and will be designed to provide a flexible privacy curtain that will retract in an emergency to address issues of gender privacy while allowing flexibility for a changing proportion of Firefighter gender.	COMPLETE
Female dorm Combined with male dorm and will be designed to provide a flexible privacy curtain that will retract in an emergency to address issues of gender privacy while allowing flexibility for a changing proportion of Firefighter gender.	COMPLETE
Officers' offer quarters (10) Seven provided per certification request/actual need of CFD. A typical shift is comprised of 16 Firefighters and 7 Officers, for a total staff of 23	COMPLETE
Day Room Combined with the Training and Community Room functions per the current CFD Prototype	COMPLETE

Fitness area/workout	COMPLETE
Male locker room	COMPLETE
Female locker room	COMPLETE
Fire coat room	COMPLETE
Apparatus exhaust system	COMPLETE
Laundry area	COMPLETE
Medical storage	COMPLETE
General storage	COMPLETE
Telecom room	COMPLETE
Day room	COMPLETE
Watch tower	COMPLETE
Kitchen	COMPLETE
Dining room	COMPLETE
Pantry	COMPLETE
Male bathroom	COMPLETE
Female bathroom	COMPLETE
Emergency generator and enclosure	COMPLETE
Litied areas = 12,534.1 SF without apparatus space	COMPLETE

PROTOTYPE PLAN - FOR REFERENCE

The current prototype, pictured below, was developed between the Chicago Fire Department and DLR Group. All requirements of the existing prototype have been met in the proposed design.

- 1. apparatus bay
- 2. hose tower
- 3. turn-out gear
- 4. watch tower
- 5. officers
- 6. storage
- 7. lockers
- 8. sleeping
- 9. physical training
- 10. mechanical
- 11. kitchen
- 12. training
- 13. patio

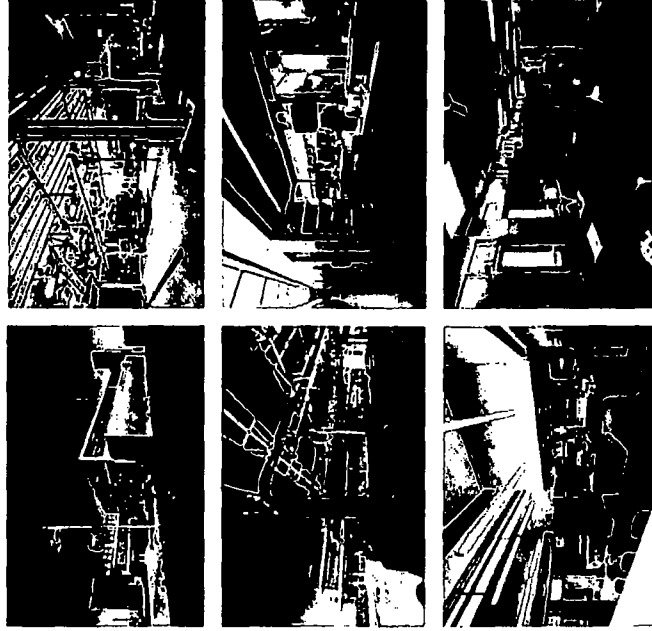
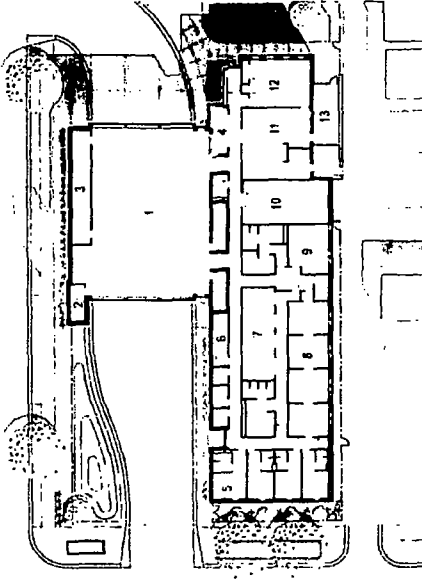

APPENDIX A: FLOOR PLAN - OPTIONAL LEVEL 3 FIRE PREVENTION

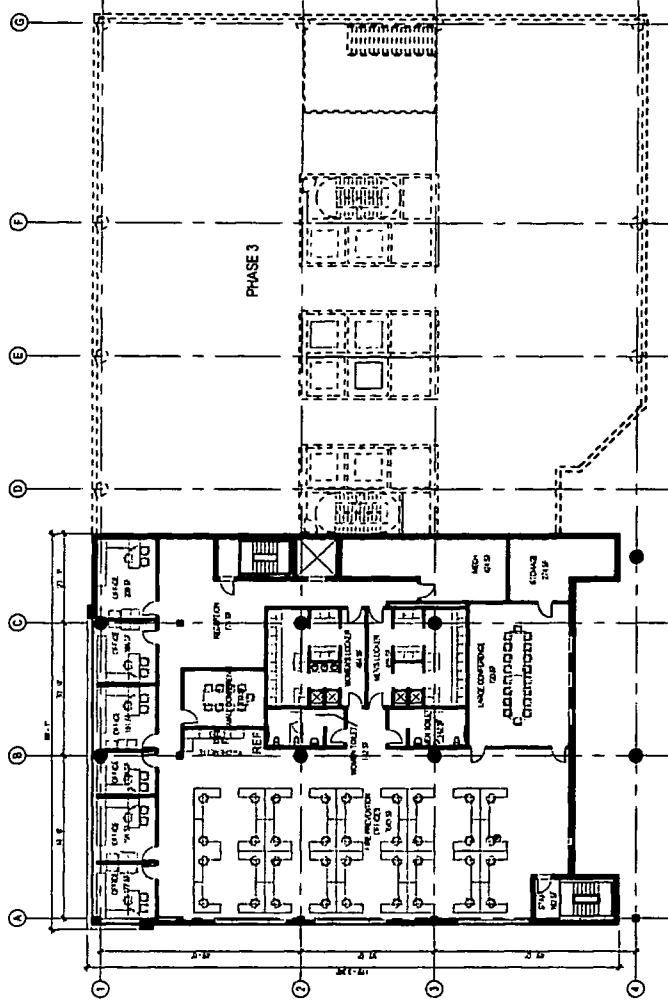

EC-42 FIRE STATION

- LEGEND:**
- 1. ALL INFORMATION IN THIS SYSTEM
 - 2. DRAWING NUMBER
 - 3. PROJECT NAME
 - 4. DRAWING DATE
 - 5. DRAWING SCALE
 - 6. DRAWING SHEET NUMBER
 - 7. DRAWING SHEET TOTAL
 - 8. DRAWING TITLE
 - 9. DRAWING DESCRIPTION
 - 10. DRAWING REVISIONS
 - 11. DRAWING REVISIONS
 - 12. DRAWING REVISIONS
 - 13. DRAWING REVISIONS
 - 14. DRAWING REVISIONS
 - 15. DRAWING REVISIONS
 - 16. DRAWING REVISIONS
 - 17. DRAWING REVISIONS
 - 18. DRAWING REVISIONS
 - 19. DRAWING REVISIONS
 - 20. DRAWING REVISIONS

AREA	AREA
AREA 1	AREA 1
AREA 2	AREA 2
AREA 3	AREA 3
AREA 4	AREA 4
AREA 5	AREA 5
AREA 6	AREA 6
AREA 7	AREA 7
AREA 8	AREA 8
AREA 9	AREA 9
AREA 10	AREA 10
AREA 11	AREA 11
AREA 12	AREA 12
AREA 13	AREA 13
AREA 14	AREA 14
AREA 15	AREA 15
AREA 16	AREA 16
AREA 17	AREA 17
AREA 18	AREA 18
AREA 19	AREA 19
AREA 20	AREA 20

EAST/WEST SECTION - OPTIONAL LEVEL 3

EC-42 FIRE STATION

- GENERAL NOTES:**
1. ALL WORK SHALL BE IN ACCORDANCE WITH THE LATEST EDITIONS OF THE IBC AND ALL APPLICABLE CODES.
 2. ALL WORK SHALL BE IN ACCORDANCE WITH THE LATEST EDITIONS OF THE IBC AND ALL APPLICABLE CODES.
 3. ALL WORK SHALL BE IN ACCORDANCE WITH THE LATEST EDITIONS OF THE IBC AND ALL APPLICABLE CODES.
 4. ALL WORK SHALL BE IN ACCORDANCE WITH THE LATEST EDITIONS OF THE IBC AND ALL APPLICABLE CODES.
 5. ALL WORK SHALL BE IN ACCORDANCE WITH THE LATEST EDITIONS OF THE IBC AND ALL APPLICABLE CODES.
 6. ALL WORK SHALL BE IN ACCORDANCE WITH THE LATEST EDITIONS OF THE IBC AND ALL APPLICABLE CODES.
 7. ALL WORK SHALL BE IN ACCORDANCE WITH THE LATEST EDITIONS OF THE IBC AND ALL APPLICABLE CODES.
 8. ALL WORK SHALL BE IN ACCORDANCE WITH THE LATEST EDITIONS OF THE IBC AND ALL APPLICABLE CODES.
 9. ALL WORK SHALL BE IN ACCORDANCE WITH THE LATEST EDITIONS OF THE IBC AND ALL APPLICABLE CODES.
 10. ALL WORK SHALL BE IN ACCORDANCE WITH THE LATEST EDITIONS OF THE IBC AND ALL APPLICABLE CODES.
 11. ALL WORK SHALL BE IN ACCORDANCE WITH THE LATEST EDITIONS OF THE IBC AND ALL APPLICABLE CODES.
 12. ALL WORK SHALL BE IN ACCORDANCE WITH THE LATEST EDITIONS OF THE IBC AND ALL APPLICABLE CODES.
 13. ALL WORK SHALL BE IN ACCORDANCE WITH THE LATEST EDITIONS OF THE IBC AND ALL APPLICABLE CODES.
 14. ALL WORK SHALL BE IN ACCORDANCE WITH THE LATEST EDITIONS OF THE IBC AND ALL APPLICABLE CODES.
 15. ALL WORK SHALL BE IN ACCORDANCE WITH THE LATEST EDITIONS OF THE IBC AND ALL APPLICABLE CODES.
 16. ALL WORK SHALL BE IN ACCORDANCE WITH THE LATEST EDITIONS OF THE IBC AND ALL APPLICABLE CODES.
 17. ALL WORK SHALL BE IN ACCORDANCE WITH THE LATEST EDITIONS OF THE IBC AND ALL APPLICABLE CODES.
 18. ALL WORK SHALL BE IN ACCORDANCE WITH THE LATEST EDITIONS OF THE IBC AND ALL APPLICABLE CODES.
 19. ALL WORK SHALL BE IN ACCORDANCE WITH THE LATEST EDITIONS OF THE IBC AND ALL APPLICABLE CODES.
 20. ALL WORK SHALL BE IN ACCORDANCE WITH THE LATEST EDITIONS OF THE IBC AND ALL APPLICABLE CODES.
 21. ALL WORK SHALL BE IN ACCORDANCE WITH THE LATEST EDITIONS OF THE IBC AND ALL APPLICABLE CODES.
 22. ALL WORK SHALL BE IN ACCORDANCE WITH THE LATEST EDITIONS OF THE IBC AND ALL APPLICABLE CODES.
 23. ALL WORK SHALL BE IN ACCORDANCE WITH THE LATEST EDITIONS OF THE IBC AND ALL APPLICABLE CODES.
 24. ALL WORK SHALL BE IN ACCORDANCE WITH THE LATEST EDITIONS OF THE IBC AND ALL APPLICABLE CODES.
 25. ALL WORK SHALL BE IN ACCORDANCE WITH THE LATEST EDITIONS OF THE IBC AND ALL APPLICABLE CODES.
 26. ALL WORK SHALL BE IN ACCORDANCE WITH THE LATEST EDITIONS OF THE IBC AND ALL APPLICABLE CODES.
 27. ALL WORK SHALL BE IN ACCORDANCE WITH THE LATEST EDITIONS OF THE IBC AND ALL APPLICABLE CODES.
 28. ALL WORK SHALL BE IN ACCORDANCE WITH THE LATEST EDITIONS OF THE IBC AND ALL APPLICABLE CODES.
 29. ALL WORK SHALL BE IN ACCORDANCE WITH THE LATEST EDITIONS OF THE IBC AND ALL APPLICABLE CODES.
 30. ALL WORK SHALL BE IN ACCORDANCE WITH THE LATEST EDITIONS OF THE IBC AND ALL APPLICABLE CODES.

NO.	DESCRIPTION	AREA
1	LEVEL 1	2,000 SF
2	LEVEL 2	2,000 SF
3	LEVEL 3	2,000 SF
4	MECHANICAL	1,000 SF
5	MECHANICAL	1,000 SF
6	MECHANICAL	1,000 SF
7	MECHANICAL	1,000 SF
8	MECHANICAL	1,000 SF
9	MECHANICAL	1,000 SF
10	MECHANICAL	1,000 SF
11	MECHANICAL	1,000 SF
12	MECHANICAL	1,000 SF
13	MECHANICAL	1,000 SF
14	MECHANICAL	1,000 SF
15	MECHANICAL	1,000 SF
16	MECHANICAL	1,000 SF
17	MECHANICAL	1,000 SF
18	MECHANICAL	1,000 SF
19	MECHANICAL	1,000 SF
20	MECHANICAL	1,000 SF
21	MECHANICAL	1,000 SF
22	MECHANICAL	1,000 SF
23	MECHANICAL	1,000 SF
24	MECHANICAL	1,000 SF
25	MECHANICAL	1,000 SF
26	MECHANICAL	1,000 SF
27	MECHANICAL	1,000 SF
28	MECHANICAL	1,000 SF
29	MECHANICAL	1,000 SF
30	MECHANICAL	1,000 SF

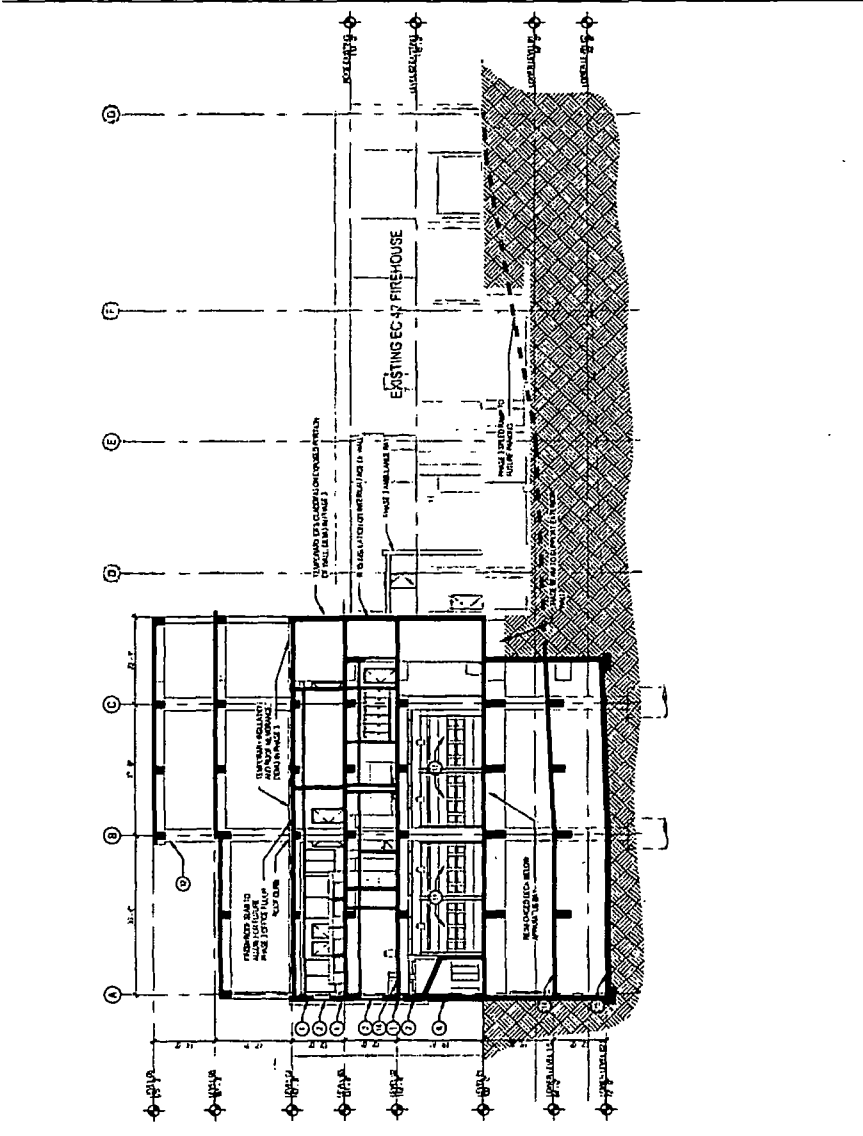

NORTH/SOUTH SECTION - OPTIONAL LEVEL 3.

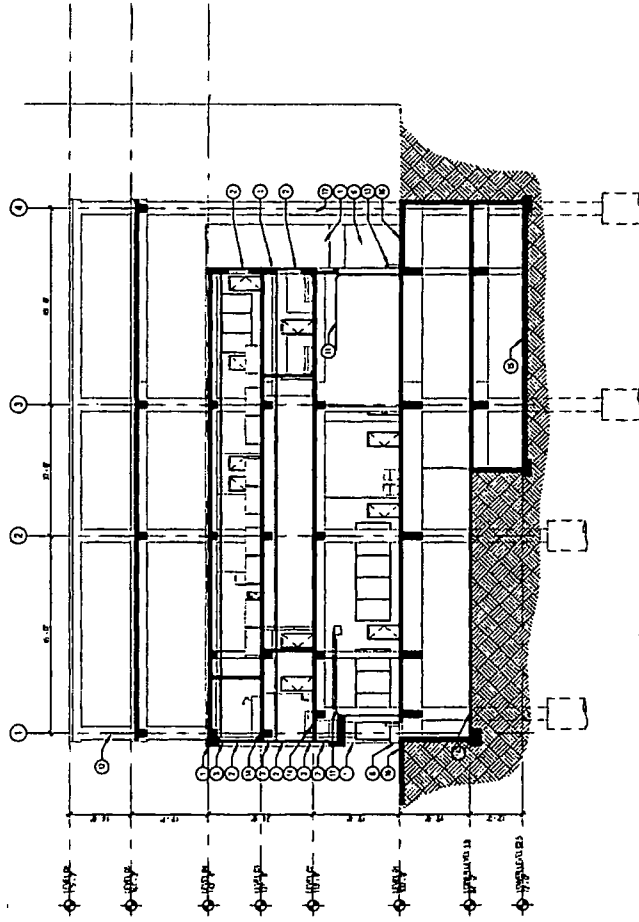

EC-42 FIRE STATION

GENERAL NOTES

1. ALL WORK SHALL BE IN ACCORDANCE WITH THE LATEST EDITIONS OF THE BUILDING CODES AND SPECIFICATIONS.
2. ALL WORK SHALL BE IN ACCORDANCE WITH THE LATEST EDITIONS OF THE BUILDING CODES AND SPECIFICATIONS.
3. ALL WORK SHALL BE IN ACCORDANCE WITH THE LATEST EDITIONS OF THE BUILDING CODES AND SPECIFICATIONS.
4. ALL WORK SHALL BE IN ACCORDANCE WITH THE LATEST EDITIONS OF THE BUILDING CODES AND SPECIFICATIONS.
5. ALL WORK SHALL BE IN ACCORDANCE WITH THE LATEST EDITIONS OF THE BUILDING CODES AND SPECIFICATIONS.
6. ALL WORK SHALL BE IN ACCORDANCE WITH THE LATEST EDITIONS OF THE BUILDING CODES AND SPECIFICATIONS.
7. ALL WORK SHALL BE IN ACCORDANCE WITH THE LATEST EDITIONS OF THE BUILDING CODES AND SPECIFICATIONS.
8. ALL WORK SHALL BE IN ACCORDANCE WITH THE LATEST EDITIONS OF THE BUILDING CODES AND SPECIFICATIONS.
9. ALL WORK SHALL BE IN ACCORDANCE WITH THE LATEST EDITIONS OF THE BUILDING CODES AND SPECIFICATIONS.
10. ALL WORK SHALL BE IN ACCORDANCE WITH THE LATEST EDITIONS OF THE BUILDING CODES AND SPECIFICATIONS.

AREA	NO.	DESCRIPTION
LEVEL 1	1000.00	1000.00
LEVEL 2	1000.00	1000.00
LEVEL 3	1000.00	1000.00
LEVEL 4	1000.00	1000.00
LEVEL 5	1000.00	1000.00
LEVEL 6	1000.00	1000.00
LEVEL 7	1000.00	1000.00
LEVEL 8	1000.00	1000.00
LEVEL 9	1000.00	1000.00
LEVEL 10	1000.00	1000.00

EXHIBIT E

PRELIMINARY NEW DEVELOPMENT PLAN

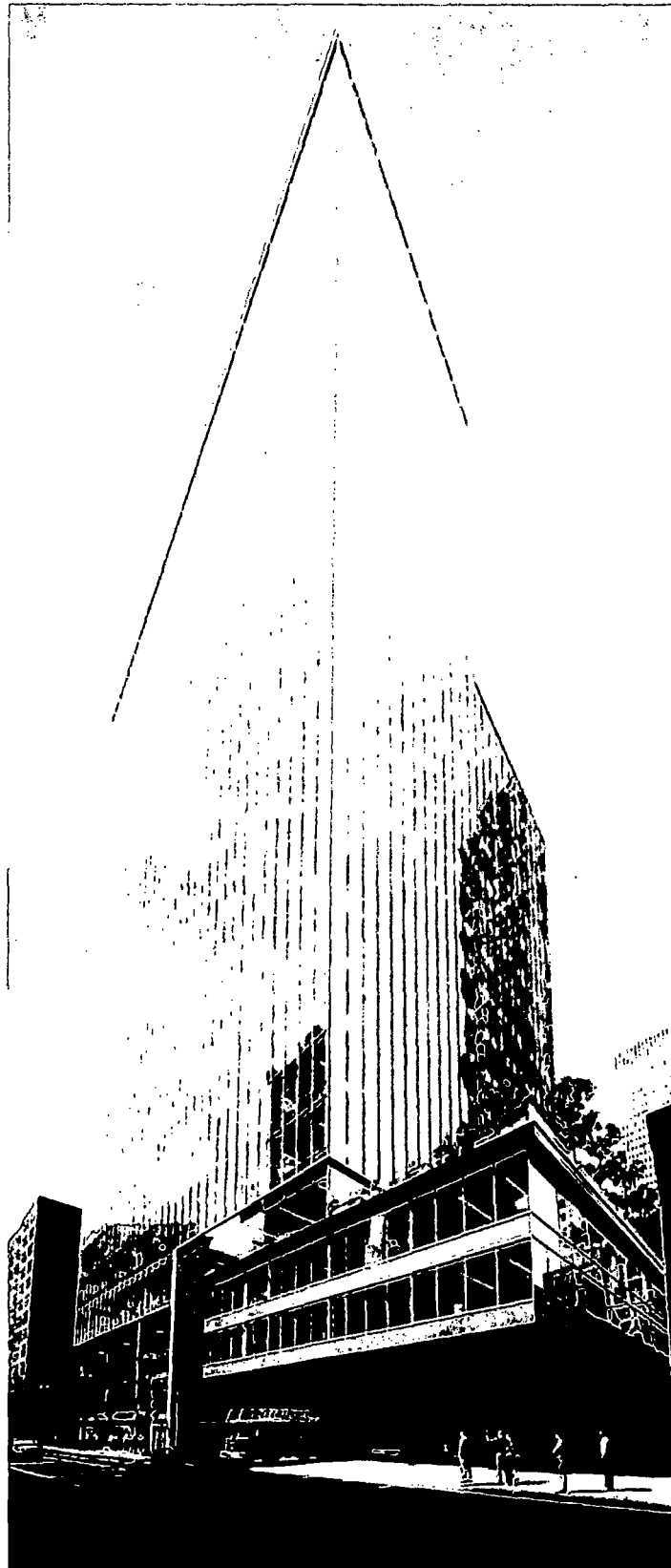

EXHIBIT F
FIREHOUSE BUDGET

FIREHOUSE/PARKING DEVELOPMENT SUMMARY	TOTAL 30,091 SF	FIREHOUSE 19,488 SF	FIRE PREVENTION 9,698 SF	FIRE PARKING 30 SPACES
Gross square footage Excluding Parking	30,130	19,488	9,698	13,841
Construction cost/gross square feet	\$581.21	\$598.92	\$344.65	\$180.43
Construction Costs Includes 5% Contingency	\$ 17,511,457	\$ 11,671,767	\$ 3,342,400	\$ 2,497,290
DEVELOPMENT COSTS				
Land Cost				
Construction Including	17,511,457	11,671,767	3,342,400	2,497,290
Soft Costs	2,312,415	1,987,415	325,000	
Construction Period taxes				
Parking Equipment	50,000			50,000
Signage (see attached)	35,000			35,000
Contingency Included In Const. Budget				
Total	\$ 19,908,872	\$ 13,659,182	\$ 3,667,400	\$ 2,582,290
Total cost/gsf	\$660.78	\$700.90	\$378.16	\$186.57
Price per Unit/Parking Space				\$86,076

EXHIBIT G

DELETED

EXHIBIT H

NEW DEVELOPMENT SPECIFICATIONS

Site Plan - Phase 1

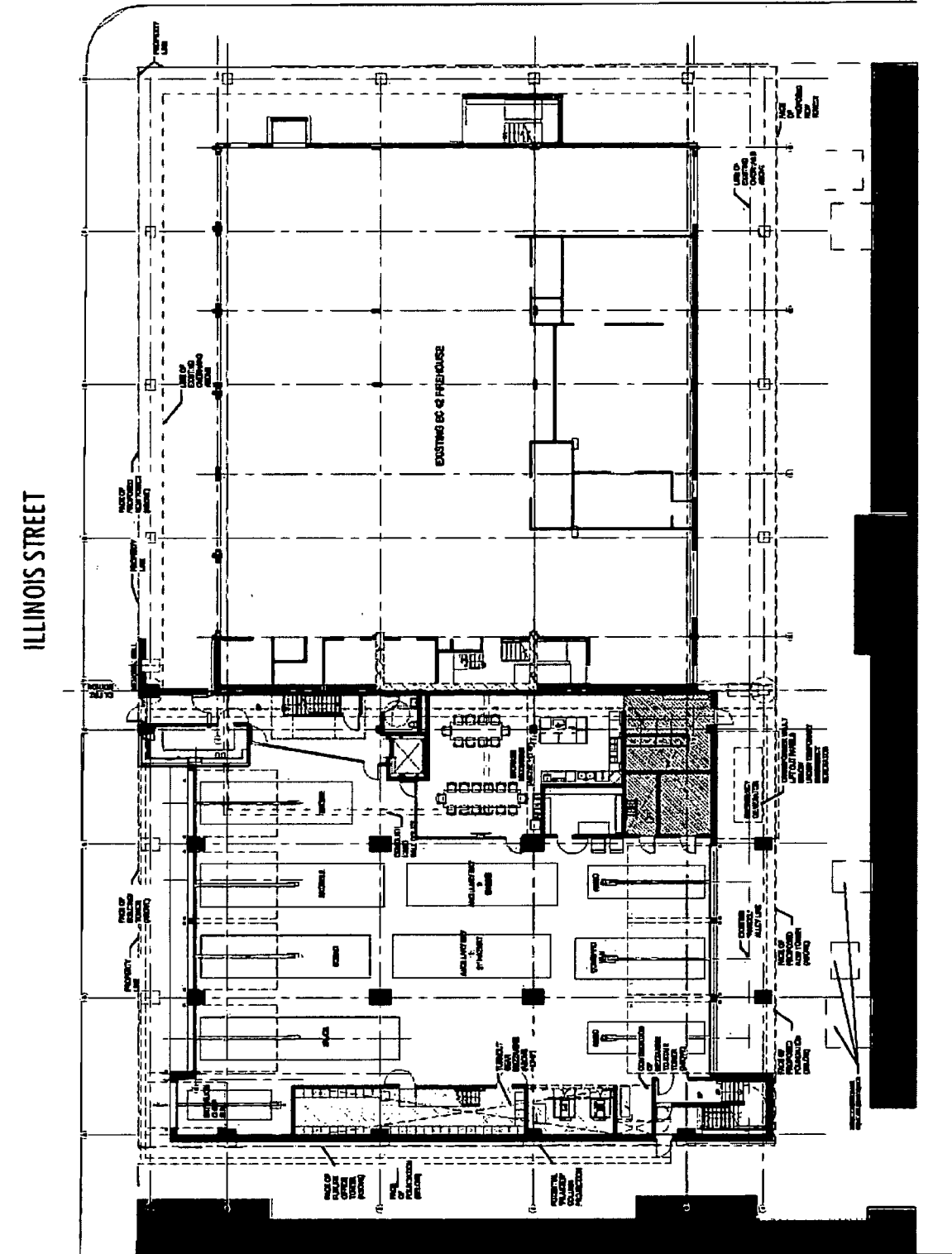

ILLINOIS STREET

DEARBORN STREET

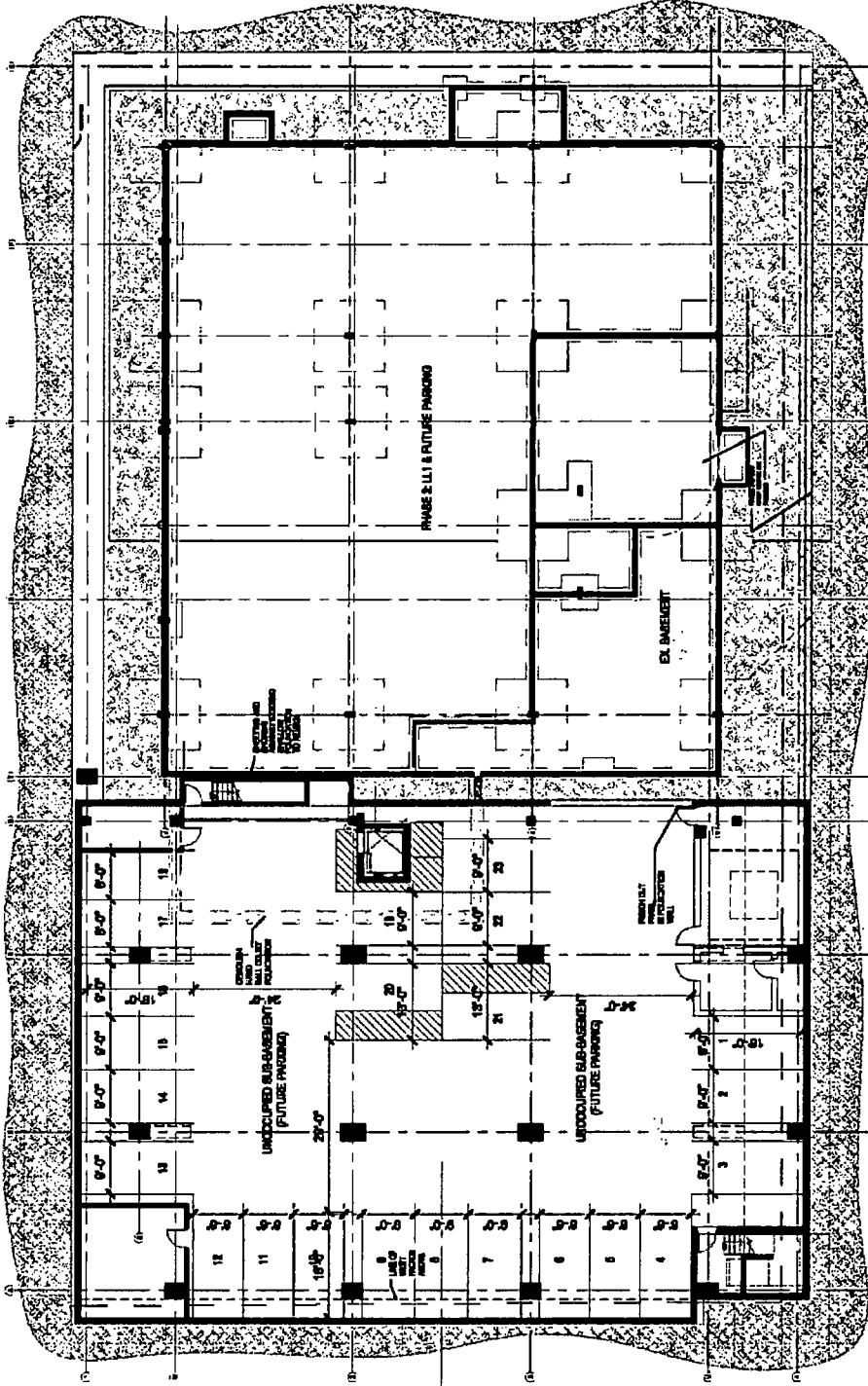

Lower Level 1 Plan – Phase 1



ILLINOIS STREET

DEARBORN STREET

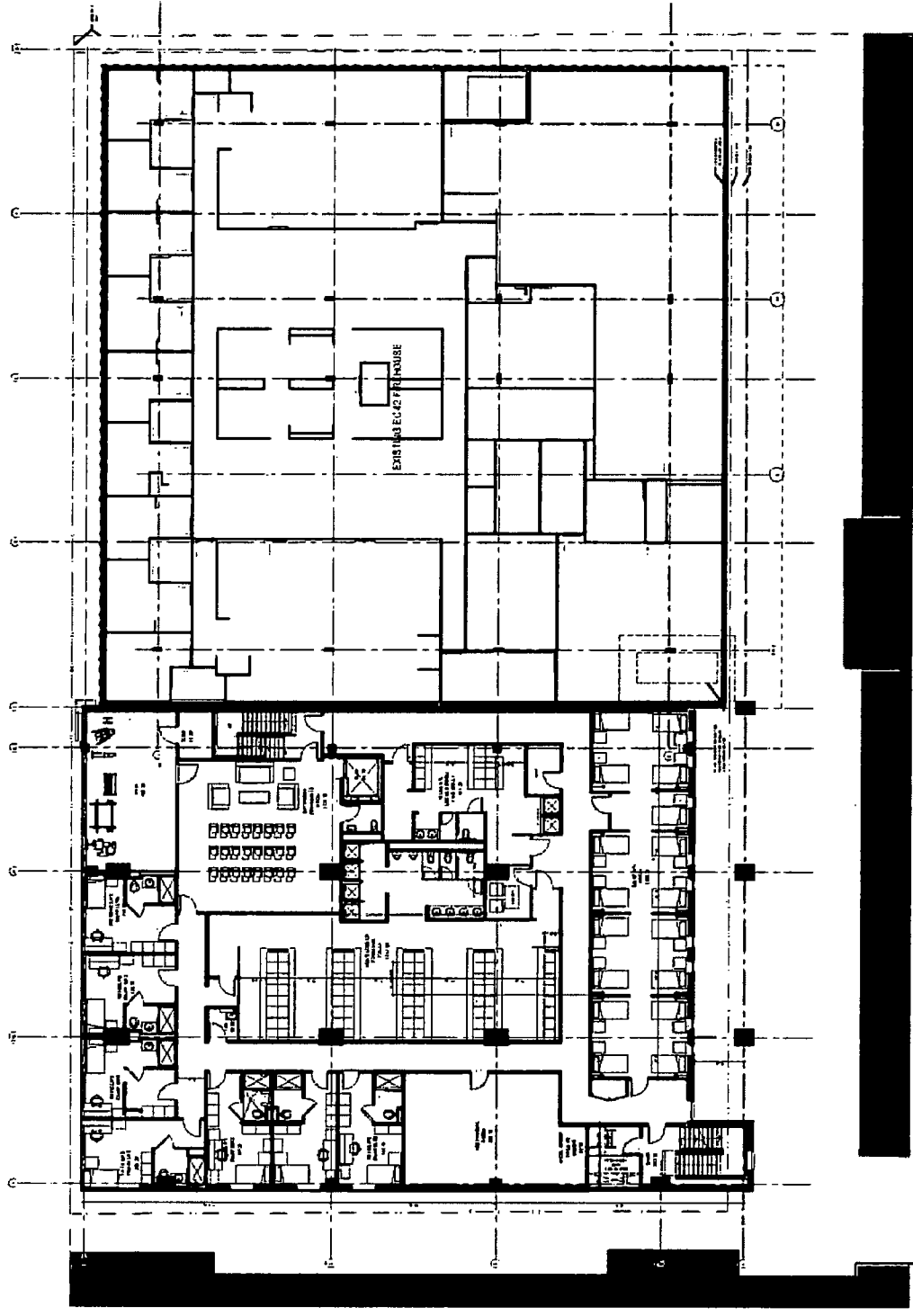

Level 2 Plan - Phase 1



ILLINOIS STREET

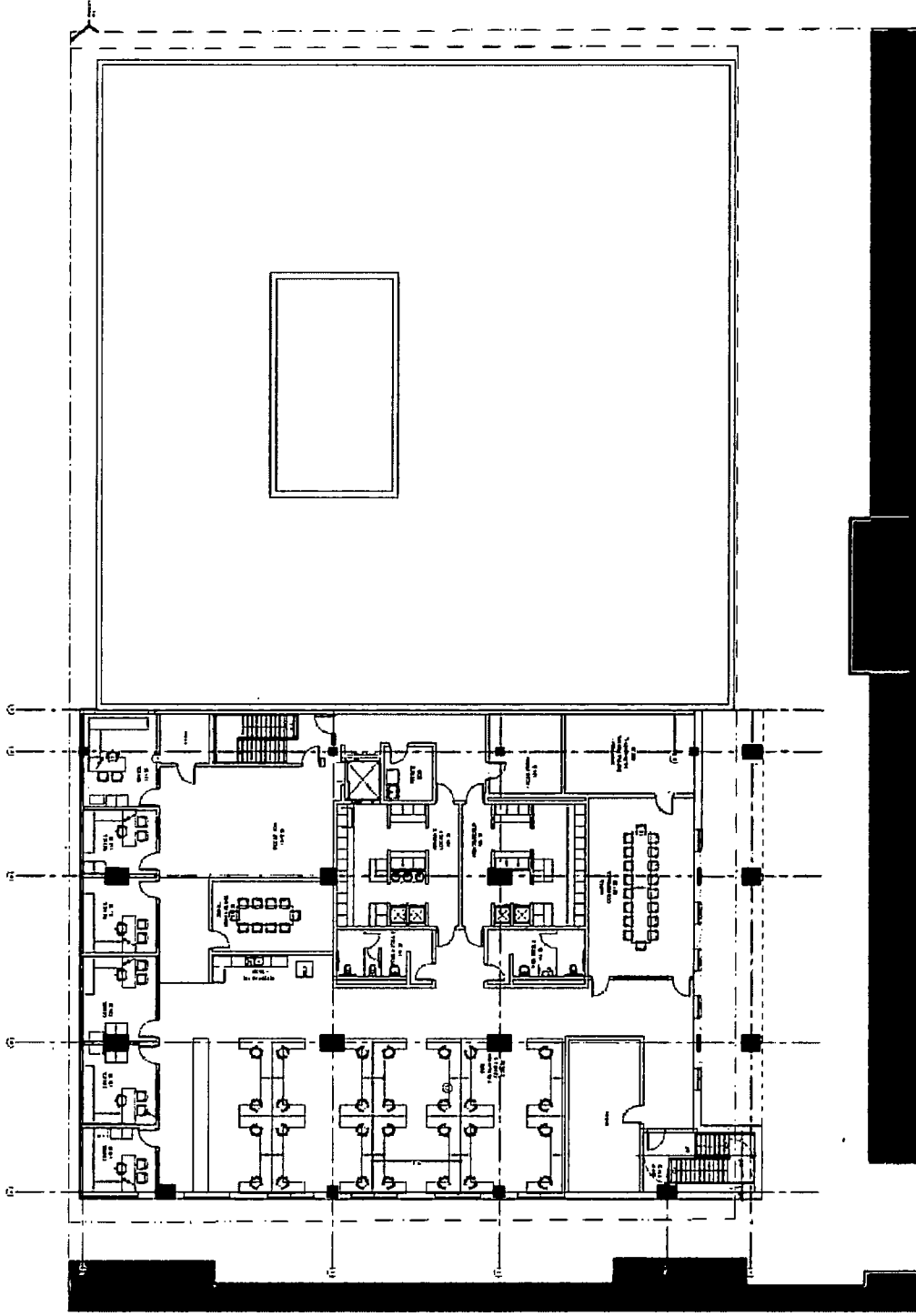

DEARBORN STREET

54 W HUBBARD

Level 3 Plan - Phase 1



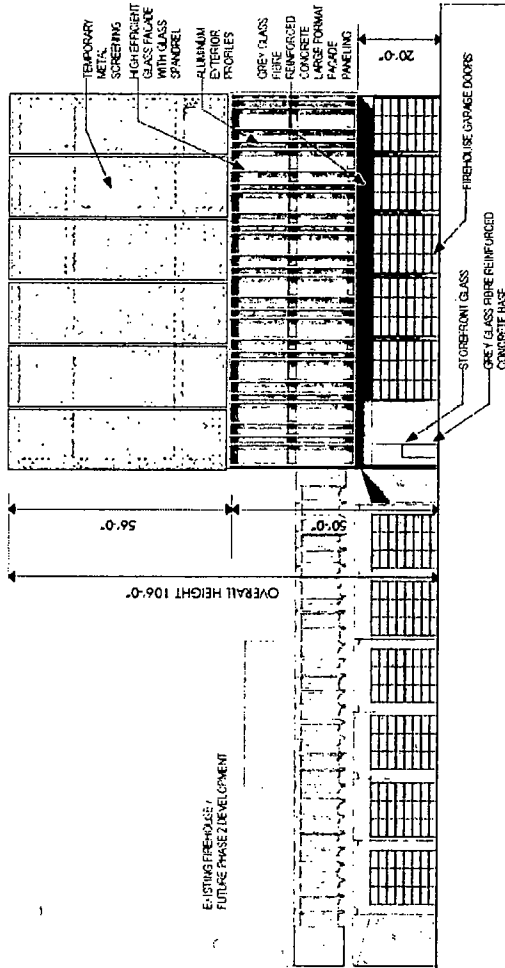
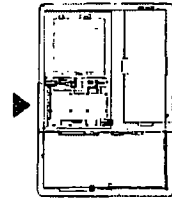
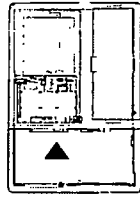

PHASE 1 FIREHOUSE - NORTH ELEVATION SCALE 1" = 30'-0"

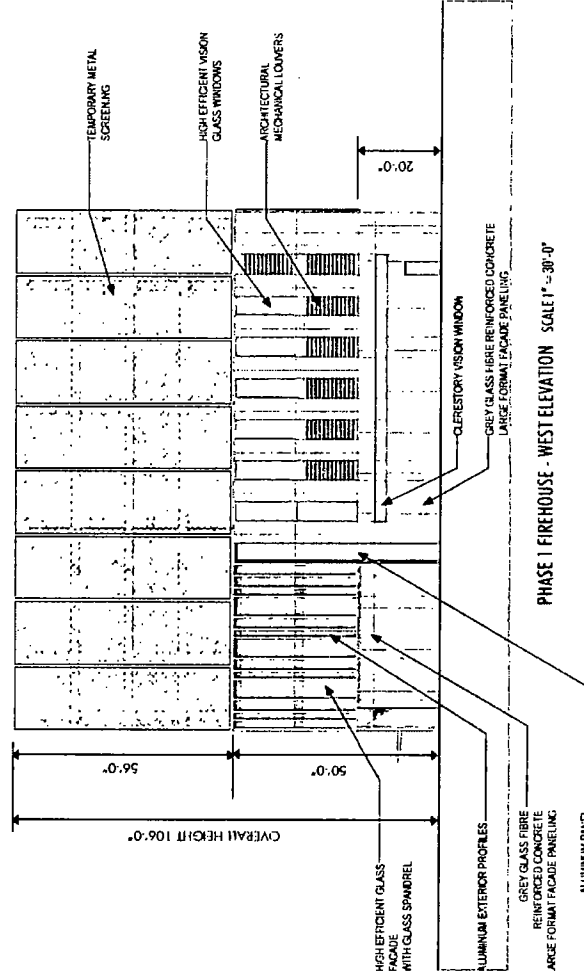

PHASE 1 FIREHOUSE - WEST ELEVATION SCALE 1" = 30'-0"

Elevations - Phase 1

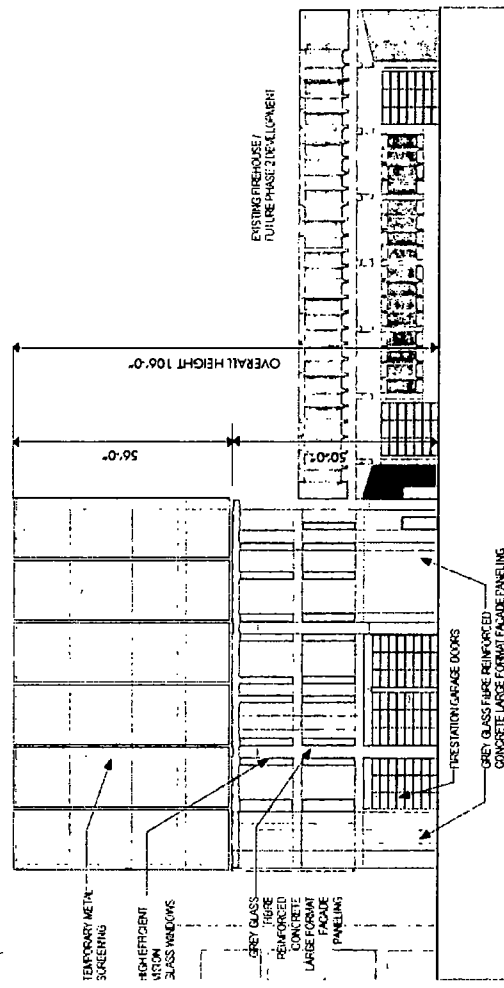
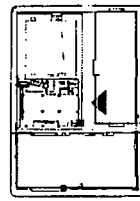
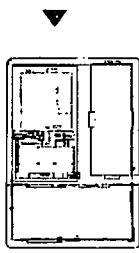

PHASE 1 FIREHOUSE - SOUTH ELEVATION SCALE 1" = 30'-0"

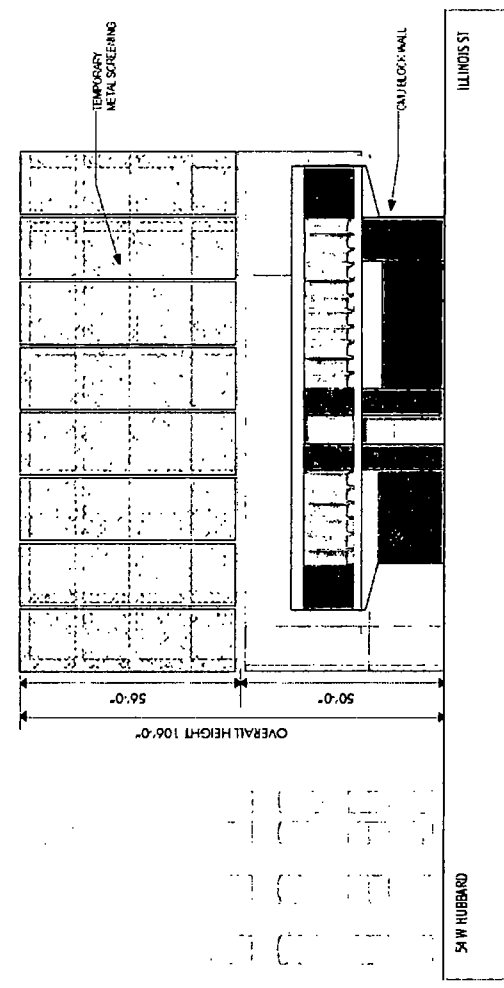

PHASE 1 FIREHOUSE EAST ELEVATION SCALE 1" = 30'-0"

Elevations - Phase 1

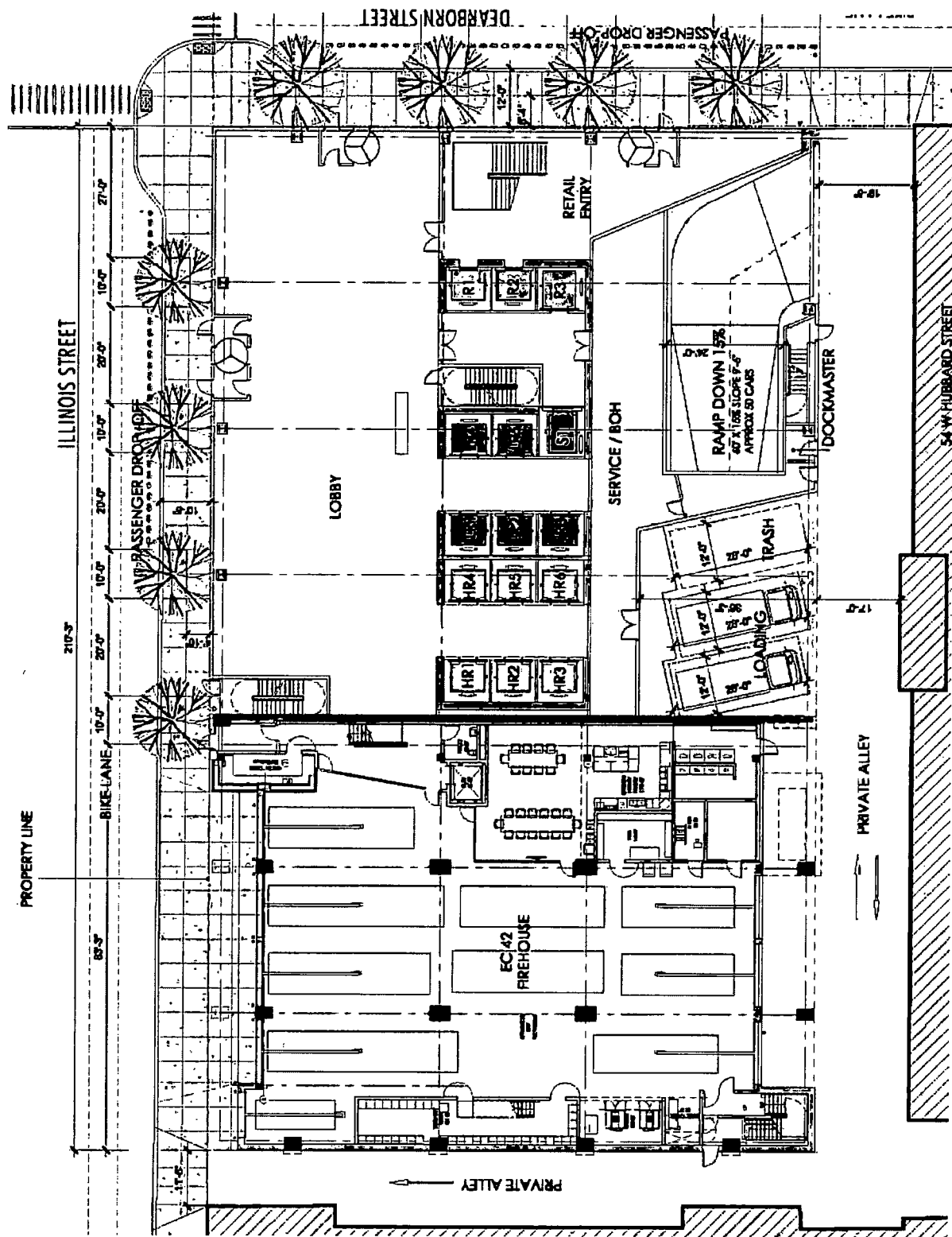

Site Plan— Phase 2



ILLINOIS STREET

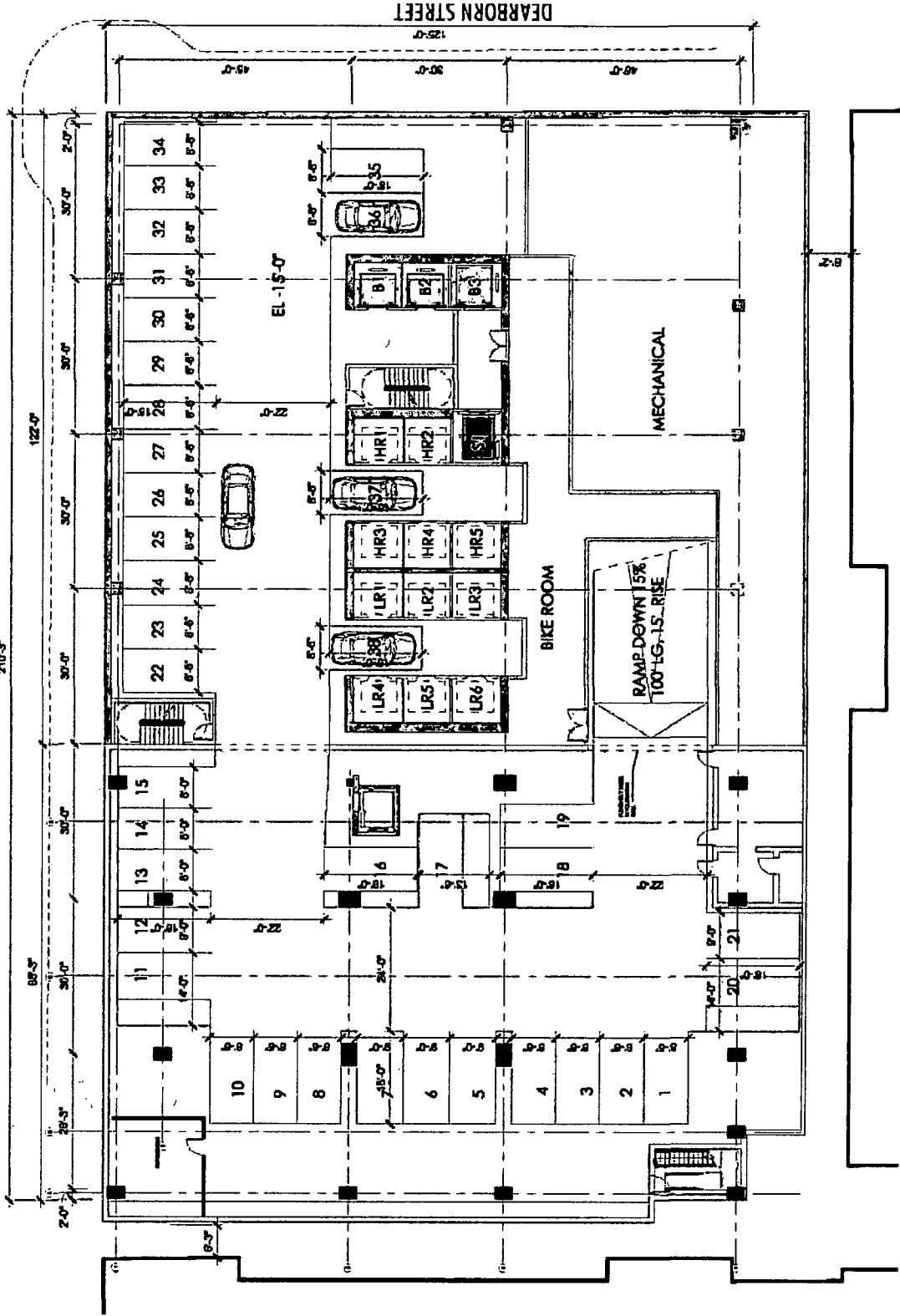

Lower Level Plan – Phase 2



ILLINOIS STREET

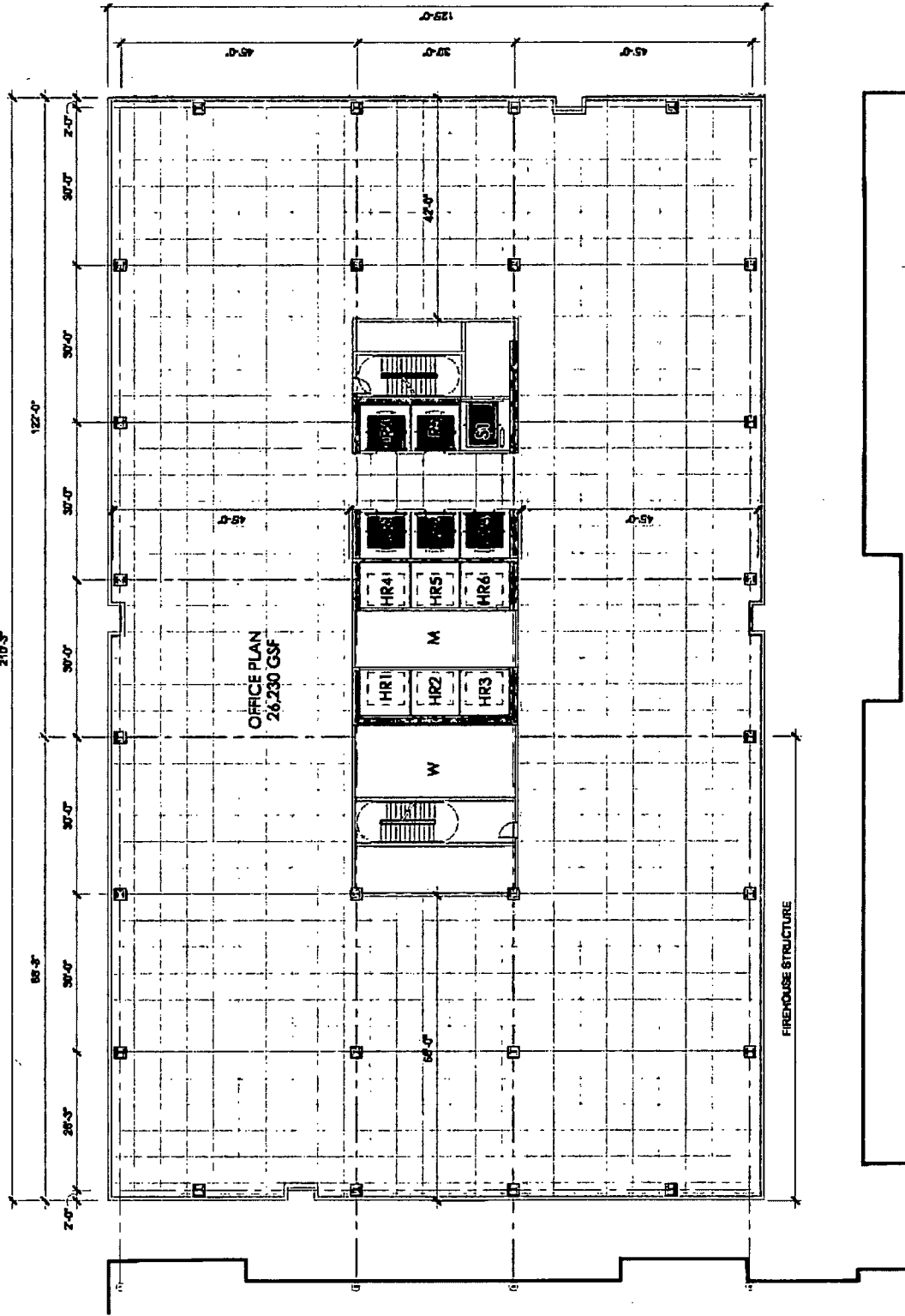

Typical Plan-- Phase 2



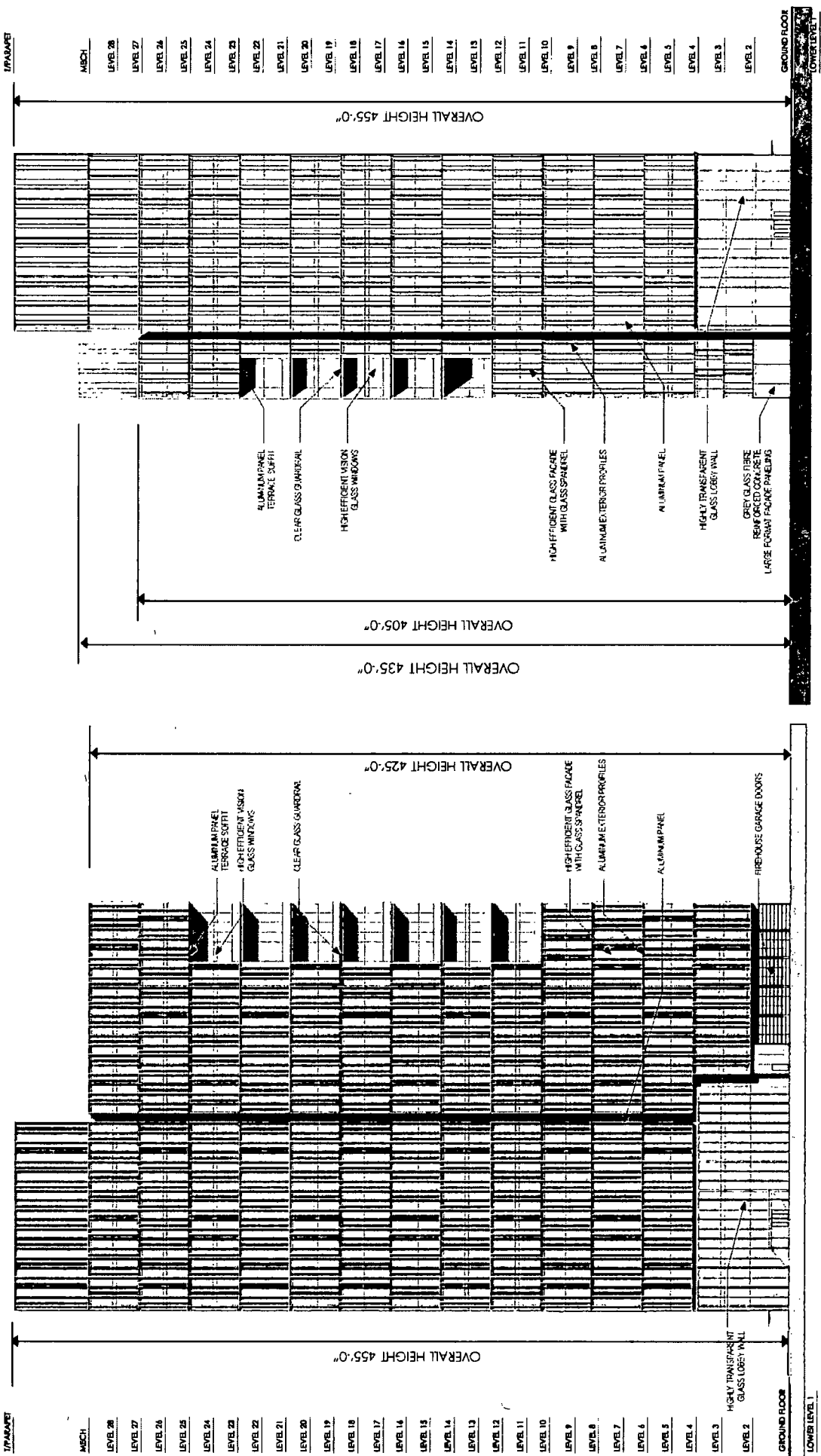

PHASE 2 NORTH ELEVATION SCALE 1" = 50'-0"

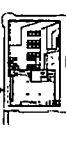

PHASE 2 EAST ELEVATION SCALE 1" = 50'-0"

Elevations

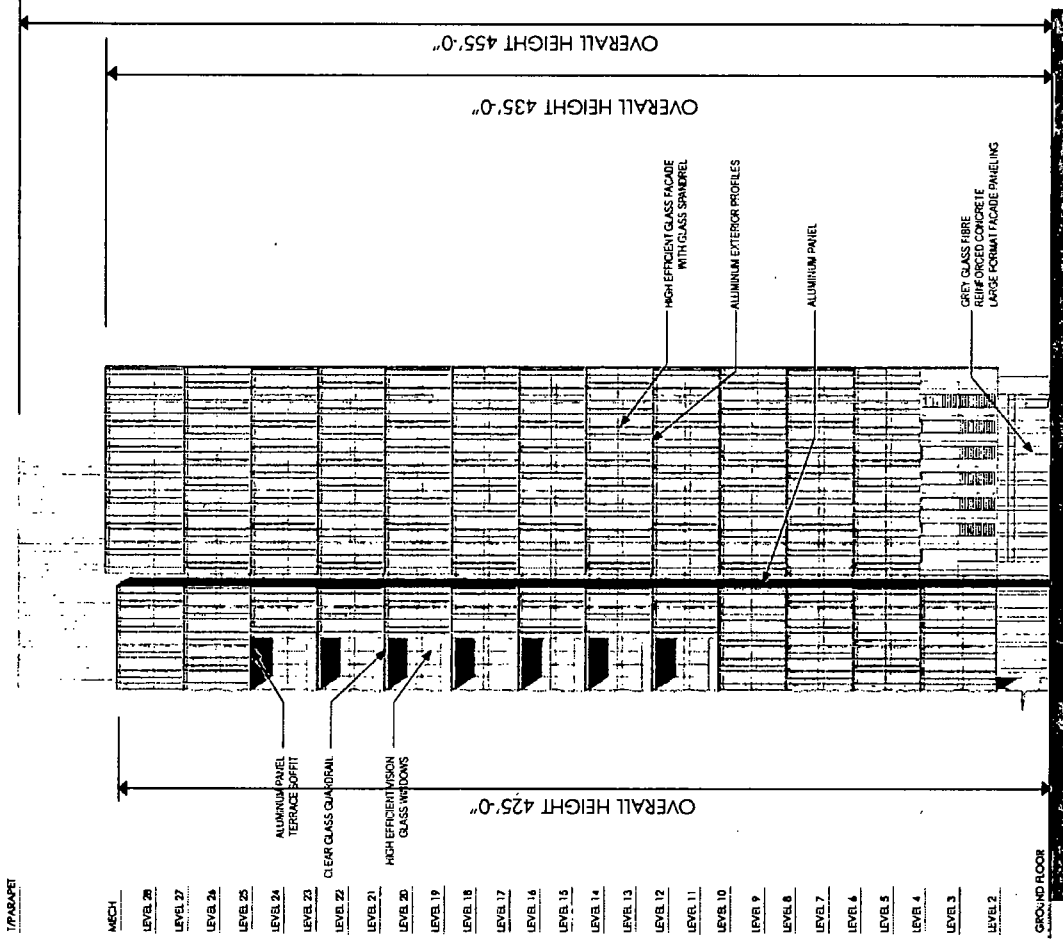

PHASE 2 WEST ELEVATION SCALE 1" = 50' 0"

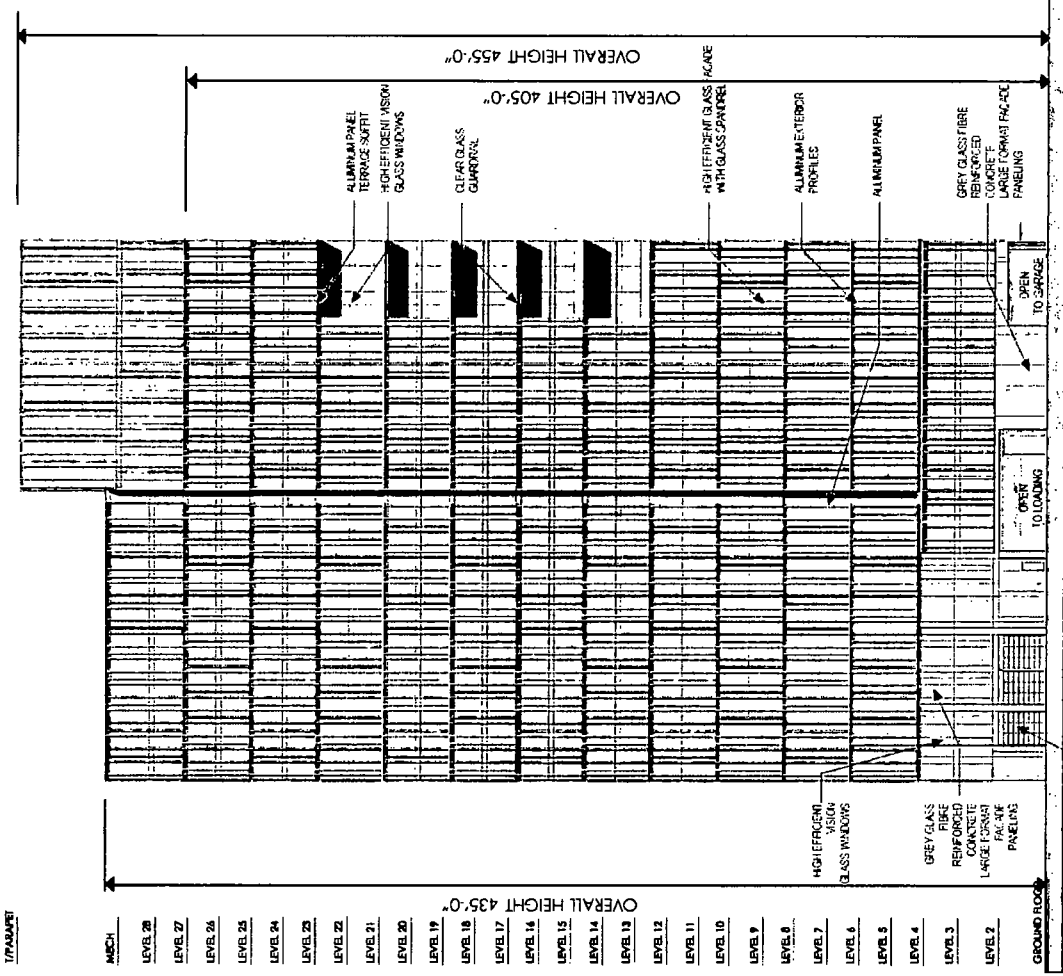

PHASE 2 SOUTH ELEVATION SCALE 1" = 50' 0"

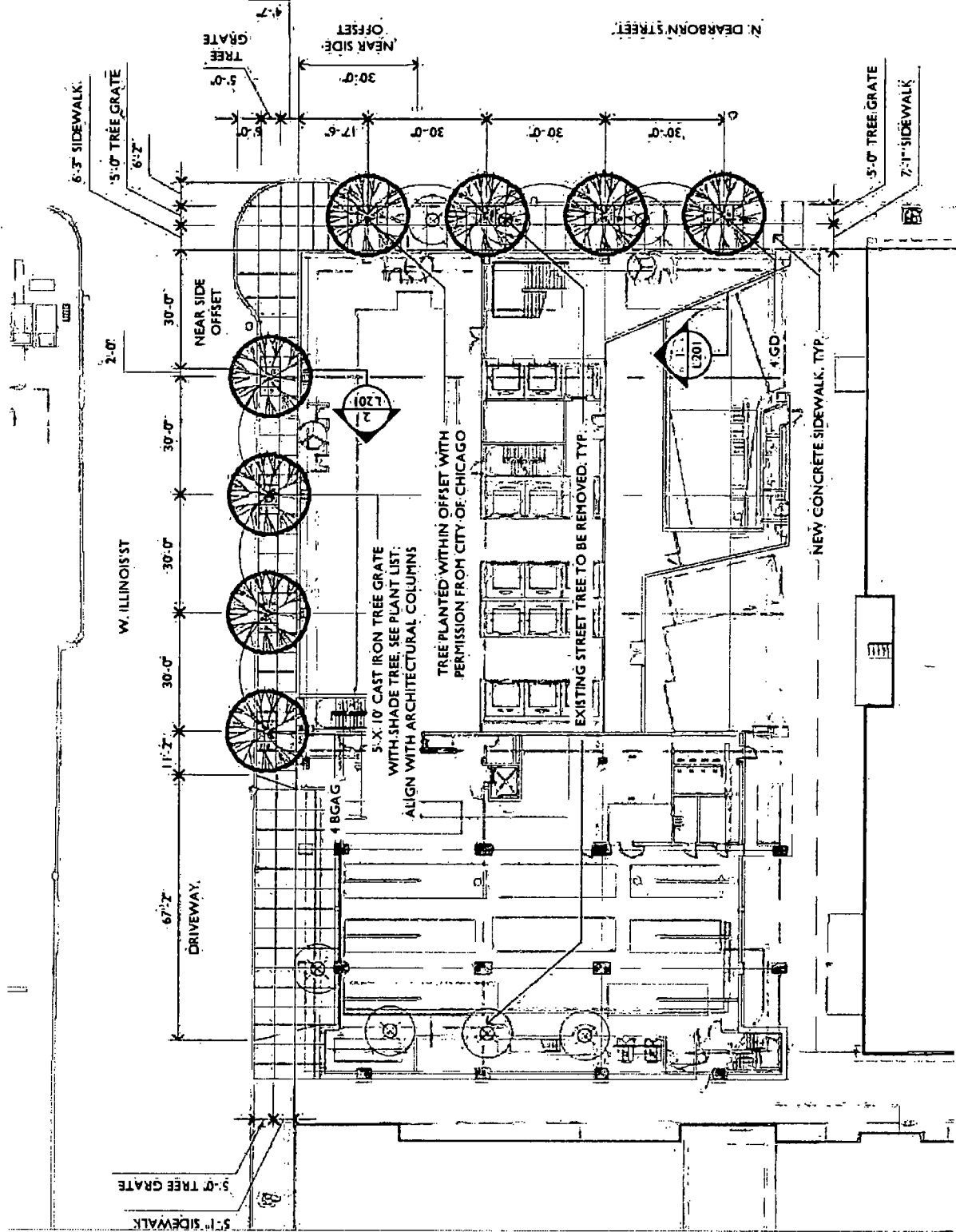

Landscape Plan—Phase 2



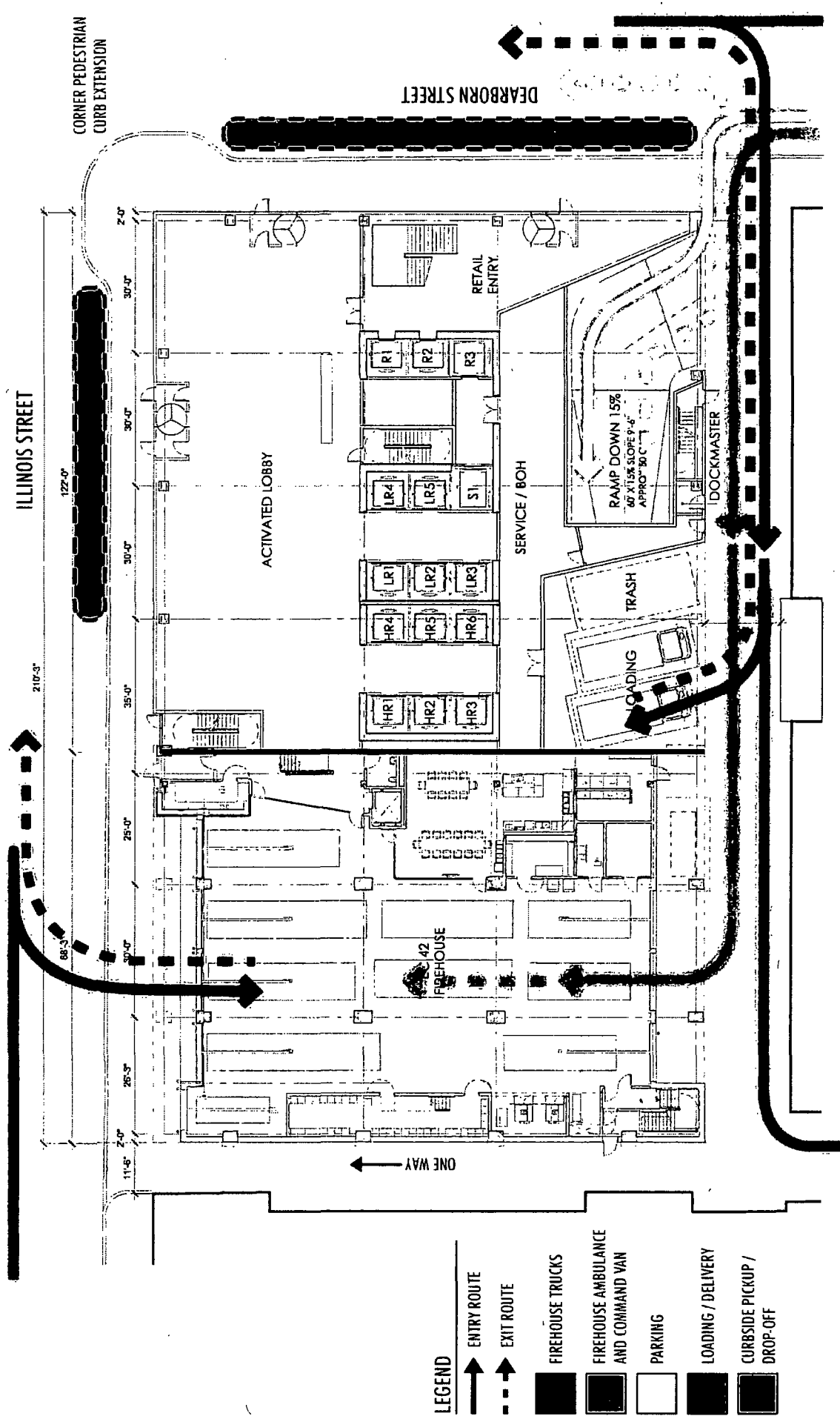

- LEGEND**
- ➔ ENTRY ROUTE
 - - -➔ EXIT ROUTE
 - FIREHOUSE TRUCKS
 - FIREHOUSE AMBULANCE AND COMMAND VAN
 - PARKING
 - LOADING / DELIVERY
 - CURBSIDE PICKUP / DROP-OFF

Vehicular and Loading Access





LEGEND

- Zone A Loading Area
- Zone B Loading Area
- Zone C Loading Area
- Zone D Loading Area
- Dock Master

NOTES

- 1) The northern segment of the north-south alley is narrowed to accommodate the new fire station footprint adjacent to current station.
- 2) Designating the northern segment of the north-south alley as one-way northbound helps to avoid conflicts of trucks attempting to travel in both directions, which currently occurs in the existing alley. It is not currently possible for trucks to pass in the existing north-south alley; thus, the narrowed alley segment does not have a direct impact on the loading relative to existing conditions.
- 3) With the narrowed width in the northern segment of the north-south alley, one-way northbound flow is recommended due to an easier exit movement into Illinois Street with its large width (2 travel lanes) compared to turning south into an 11'-6" wide alley.
- 4) A full-time dock master will monitor all movements and loading activity in the alleys throughout the block.
- 5) Generation and chimney removal in the existing east-west alley effectively increases the alley width compared to existing conditions.
- 6) Zone D is comprised of office uses with minimal alley loading needs and is served primarily by short-term office-related deliveries using the curbside zone (No Parking) in front of the building on Hubbard Street.

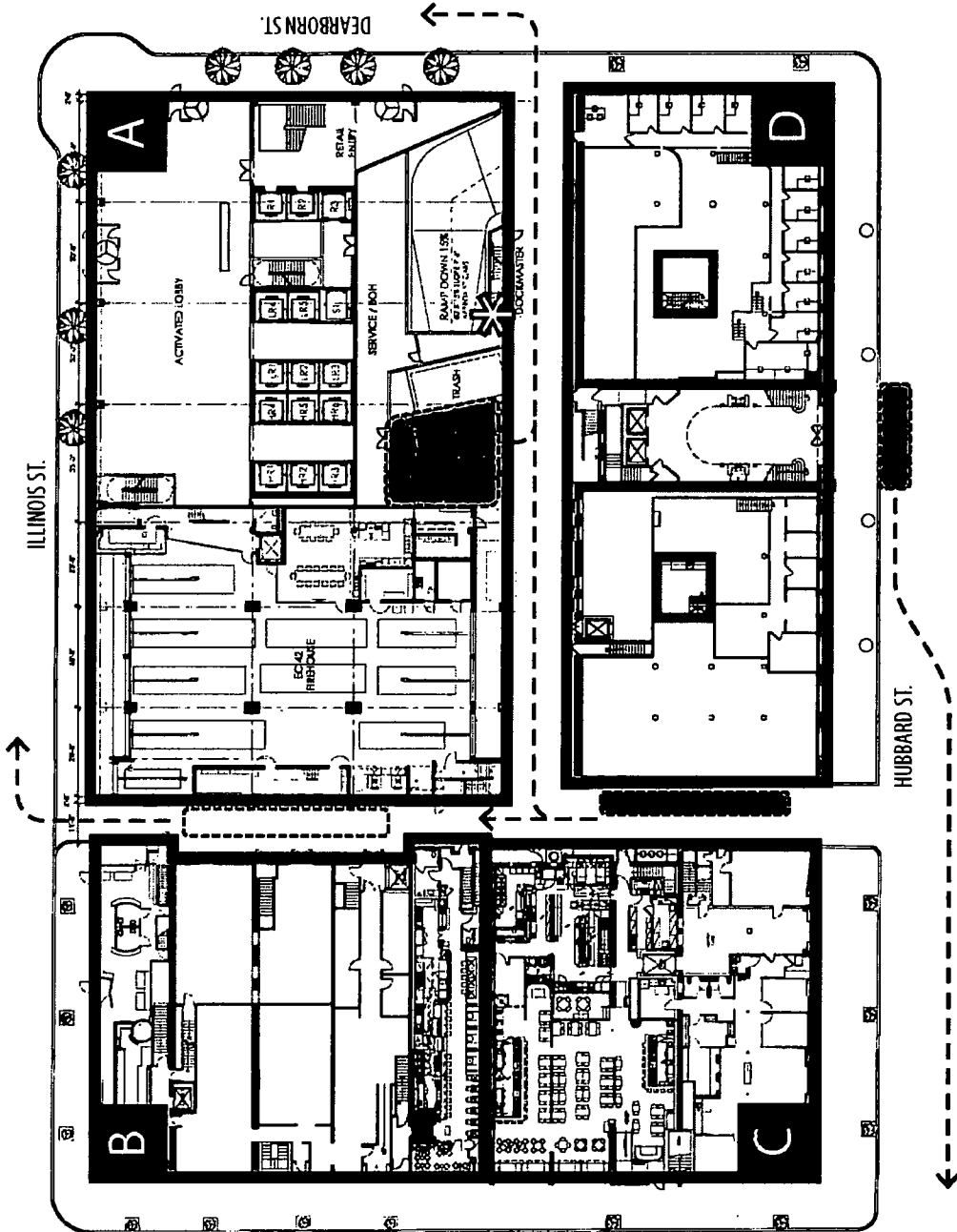



View at Dearborn looking west

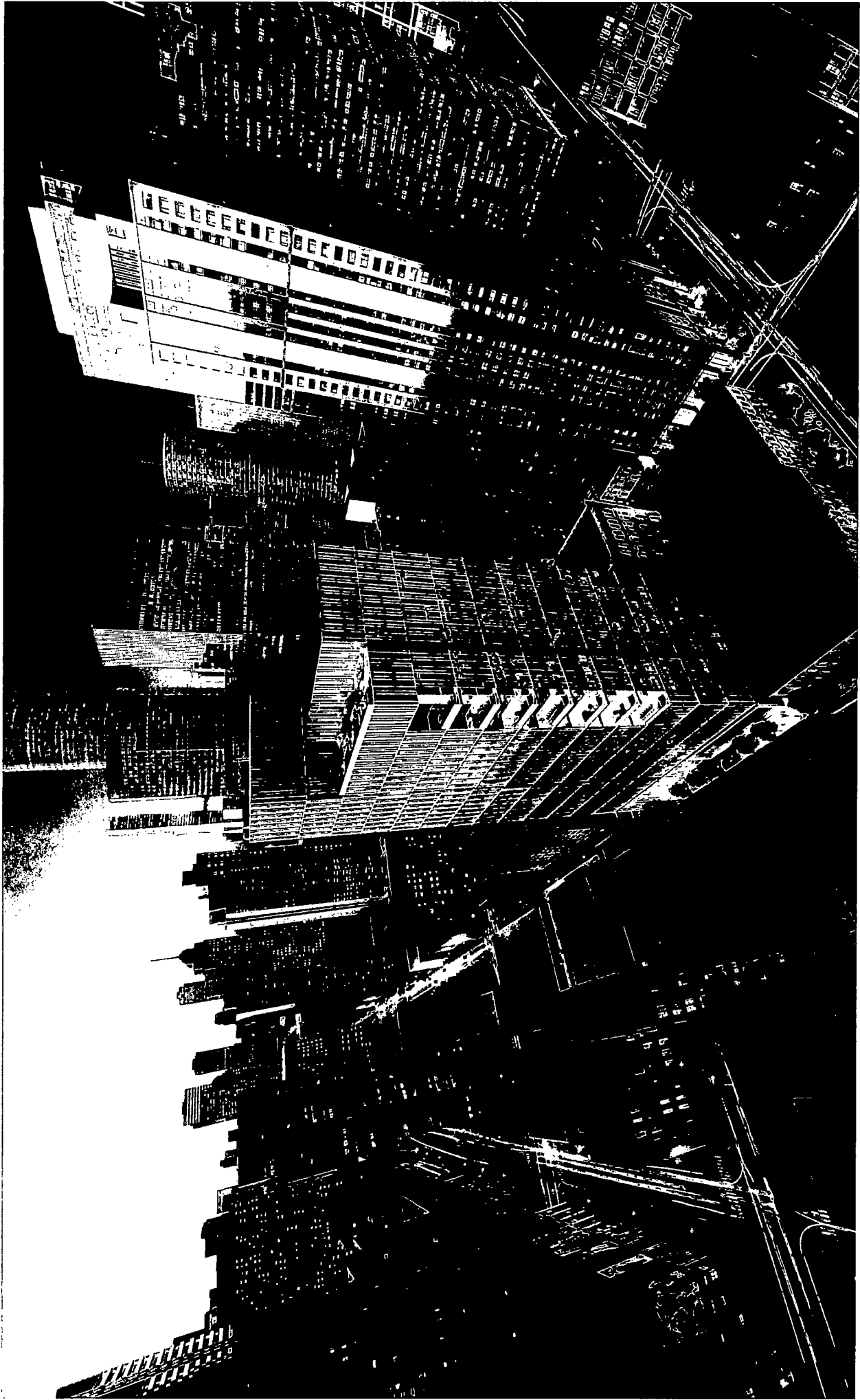

Aerial View looking east



View along Dearborn Street



View along Illinois Street

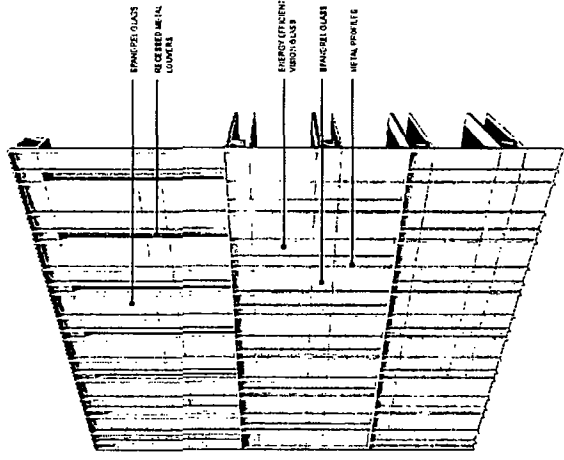

FACADE INFO AT PENTHOUSE

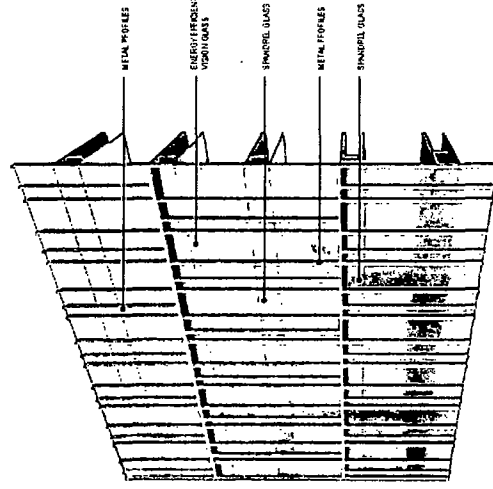
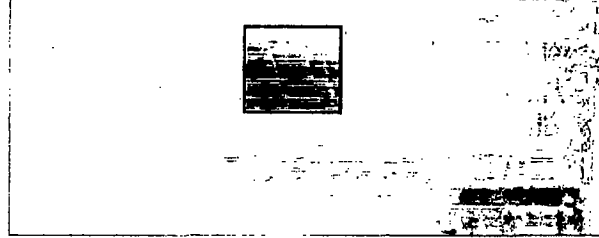

TYPICAL FACADE INFO / FLOOR TO FLOOR SECTIONS

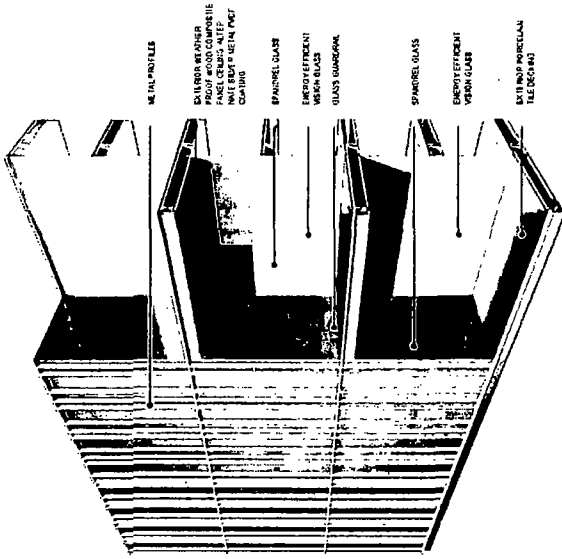
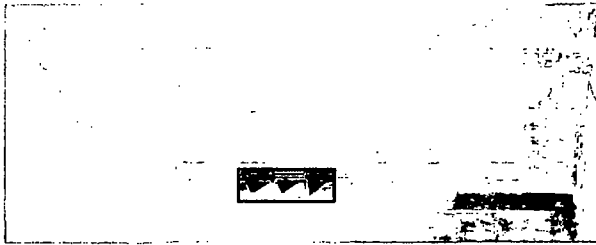

METAL PROFILES

EXTERIOR WEATHER
RESISTANT
FACELANDS ALUMINUM
WHITE EPOXY METAL PRIMER
COATING

SPANDREL GLASS

ENERGY EFFICIENT
VIBRIL GLASS
GLASS SUBSTRATE

SPANDREL GLASS

ENERGY EFFICIENT
VIBRIL GLASS

EXTERIOR PORCELAIN
TILE (600x600)

FACADE INFO AT TERRACES

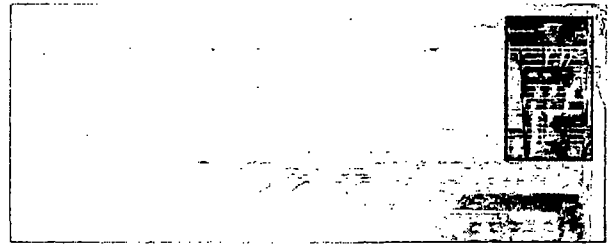

SPANDREL GLASS

METAL PROFILES

ENERGY EFFICIENT
VIBRIL GLASS

METAL MULLING

UPWARD TRANSPIRENT
LOBBY GLASS

FACADE INFO AT BASE/LOBBY

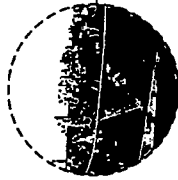
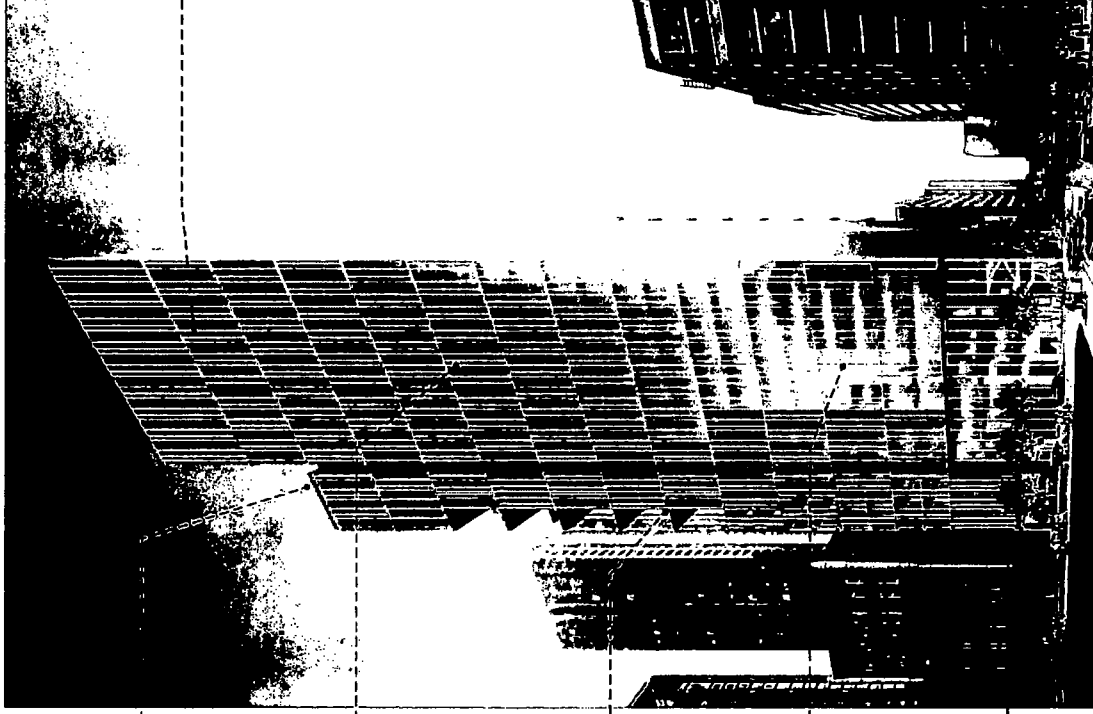

ACTIVATED ROOFTOPS
GREEN ROOFS REDUCE HEAT ISLAND EFFECT
AND FORM TRANQUIL EXTERIOR SPACES



DAYLIGHT AND VIEWS
INCREASED DAYLIGHT AND VIEWS WITHIN
HIGH ENERGY ENCLOSURE TO REDUCE
LIGHTING LOADS



RAINWATER COLLECTION
GRAYWATER AND RAINWATER ARE
COLLECTED AND DISTRIBUTED TO THE CBD
FOR RE-USE

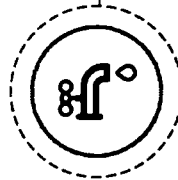

WATER EFFICIENCY
REDUCTION OF WATER
CONSUMPTION BY OVER 20%

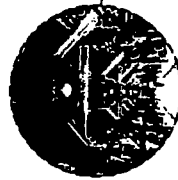

DISTRICT HEATING/COOLING
REDUCES LAND USAGE AS
COMPARED TO INDIVIDUAL BUILDING
COOLING SYSTEMS



**HIGH-PERFORMANCE
FACADE**
DECREASES ENERGY

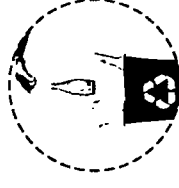

WASTE MANAGEMENT
COMPREHENSIVE PLAN FOR WASTE
REDUCTION, RE-USE, AND RECYCLING OF
MATERIALS



REGENERATIVE LIFT TECHNOLOGY
DECREASES ENERGY USAGE AND
INCREASES EFFICIENCY

SUSTAINABILITY

Project Sustainable Design

EXHIBIT I

NEW FIREHOUSE PARCEL

THAT PART OF BLOCK 7 LYING EAST OF THE EAST LINE OF LOTS 1 THROUGH 9 IN SAID BLOCK 7, IN JOHN S. PRUSSING'S SUBDIVISION OF BLOCKS 7 AND 10 IN WOLCOTT'S ADDITION TO CHICAGO IN THE EAST HALF OF THE NORTHEAST QUARTER OF SECTION 9, TOWNSHIP 39 NORTH, RANGES 14, EAST OF THE THIRD PRINCIPAL MERIDIAN, LYING BELOW A HORIZONTAL PLANE HAVING AN ELEVATION OF +64.50 FEET CHICAGO CITY DATUM AND LYING ABOVE A HORIZONTAL PLANE HAVING AN ELEVATION OF +14.00 FEET CHICAGO CITY DATUM AND LYING WITHIN ITS HORIZONTAL BOUNDARY PROJECTED VERTICALLY AND DESCRIBED AS FOLLOWS:

COMMENCING AT THE NORTHWEST CORNER OF BLOCK 7 IN JOHN S. PRUSSING'S SUBDIVISION AFORESAID; THENCE SOUTH 90 DEGREES 00 MINUTES 00 SECONDS EAST ALONG THE NORTH LINE OF SAID BLOCK 7 A DISTANCE OF 109.85 FEET TO THE POINT OF BEGINNING; THENCE SOUTH 90 DEGREES 00 MINUTES 00 SECONDS EAST ALONG THE NORTH LINE OF SAID BLOCK 7 A DISTANCE OF 89.20 FEET; THENCE SOUTH 00 DEGREES 16 MINUTES 14 SECONDS EAST 125.00 FEET; THENCE NORTH 90 DEGREES 00 MINUTES 00 SECONDS WEST 89.10 FEET; THENCE NORTH 00 DEGREES 19 MINUTES 07 SECONDS WEST 125.00 FEET TO THE POINT OF BEGINNING;

TOGETHER WITH

THAT PART OF BLOCK 7 LYING EAST OF THE EAST LINE OF LOTS 1 THROUGH 9 IN SAID BLOCK 7, IN JOHN S. PRUSSING'S SUBDIVISION OF BLOCKS 7 AND 10 IN WOLCOTT'S ADDITION TO CHICAGO IN THE EAST HALF OF THE NORTHEAST QUARTER OF SECTION 9, TOWNSHIP 39 NORTH, RANGES 14, EAST OF THE THIRD PRINCIPAL MERIDIAN, LYING BELOW A HORIZONTAL PLANE HAVING AN ELEVATION OF +14.00 FEET CHICAGO CITY DATUM AND LYING WITHIN ITS HORIZONTAL BOUNDARY PROJECTED VERTICALLY AND DESCRIBED AS FOLLOWS:

COMMENCING AT THE NORTHWEST CORNER OF BLOCK 7 IN JOHN S. PRUSSING'S SUBDIVISION AFORESAID; THENCE SOUTH 90 DEGREES 00 MINUTES 00 SECONDS EAST ALONG THE NORTH LINE OF SAID BLOCK 7 A DISTANCE OF 106.57 FEET TO THE POINT OF BEGINNING; THENCE SOUTH 90 DEGREES 00 MINUTES 00 SECONDS EAST ALONG THE NORTH LINE OF SAID BLOCK 7 A DISTANCE OF 92.48 FEET; THENCE SOUTH 00 DEGREES 16 MINUTES 14 SECONDS EAST 125.00 FEET; THENCE NORTH 90 DEGREES 00 MINUTES 00 SECONDS WEST 89.10 FEET; THENCE NORTH 00 DEGREES 19 MINUTES 07 SECONDS WEST 19.33 FEET; THENCE NORTH 90 DEGREES 00 MINUTES 00 SECONDS WEST 3.86 FEET; THENCE NORTH 00 DEGREES 00 MINUTES 00 SECONDS EAST 105.67 FEET TO THE POINT OF BEGINNING, IN COOK COUNTY, ILLINOIS.
AREA AT ELEVATION +14.00 CCD = 11,521 SQUARE FEET OR 0.26 ACRES, MORE OR LESS.

EXHIBIT J
TRANSFER CITY PROPERTY

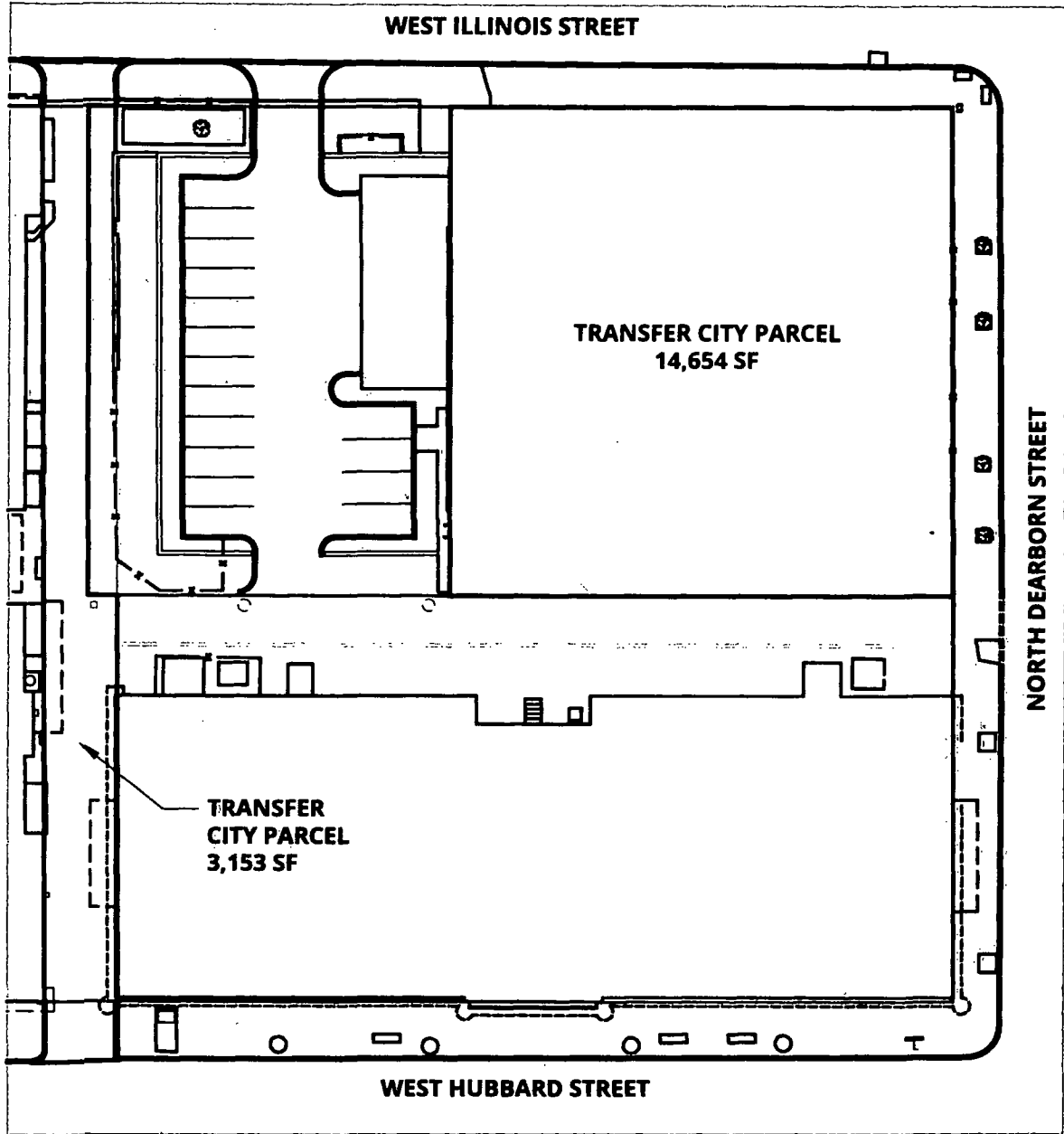

Note: Subject premises is unshaded

FRIEDMAN
PROPERTIES
312.644.1100 | friedmanproperties.com

55 W Illinois Street
Transfer City Parcel

02/15/2017

EXHIBIT K

ESCROW AGREEMENT

THIS ESCROW AGREEMENT, made and entered into this _____, 2018 (“**Effective Date**”), by and among the **CITY OF CHICAGO**, an Illinois home rule municipal corporation (“**City**”), **EC 42 DEVELOPER LLC**, an Illinois limited liability company (“**Developer**”), and **NEAR NORTH NATIONAL TITLE, LLC**, a Delaware limited liability company (“**Escrow Agent**”). All capitalized terms not otherwise defined in this Escrow Agreement shall have the meaning ascribed to them in the Agreement (as defined below).

WHEREAS, the City and Developer are parties to that certain Redevelopment Agreement, effective as of _____, 2018 (“**Agreement**”); and

WHEREAS, the Agreement provides, among other things, for the City to transfer to the Developer the Transfer City Property (as defined in the Agreement); and

NOW, THEREFORE, in consideration of Ten Dollars (\$10.00) and other good and valuable consideration, the receipt and sufficiency of which are hereby acknowledged, and of the mutual covenants herein set forth, the City, Developer, and Escrow Agent agree as follows:

- I. All capitalized terms not defined herein shall have the same meaning as set forth in the Agreement.
- II. On or prior to the Phase I Closing, the City shall provide Escrow Agent, and Escrow Agent shall accept from the City, the following original documents duly executed by the City or the other appropriate parties (hereinafter referred to as the “**City Escrowed Documents**”):
 1. Quitclaim Deed to the Transfer City Property;
 2. Bill of sale for any personal property that is part of the Acquisition Property;
 3. FIRPTA certifications;
 4. Transfer Declaration;
 5. GAP and ALTA Statement;
 6. Sums due to the Developer, if any;
 7. Closing Statement;
 8. REA;
 9. Ground Lease
 10. Temporary Parking Agreement;
 11. Permanent Parking Agreement.
- III. On or prior to the Phase I Closing, Developer shall provide Escrow Agent, and Escrow Agent shall accept from Developer, the following original documents duly executed by Developer or the other appropriate parties (hereinafter referred to as the “**Developer Escrowed Documents**”) (the City Escrowed Documents and Developer Escrowed Documents are, collectively, the “**Closing Documents**”):
 1. GAP and ALTA Statement;
 2. Closing Statement;
 3. Sums due to the City, if any;
 4. Purchase Price;
 5. REA;
 6. Ground Lease;

7. The Temporary Parking Agreement;
8. Permanent Parking Agreement.
9. Written confirmation under the Office Lease Condition pursuant to Paragraph 7.D.9 of the Agreement; and
10. Performance Security letter of credit.

IV. Escrow Agent shall hold the Closing Documents in escrow until:

1. Escrow Agent receives written authorization via email from the City's counsel, Peter M. Friedman of Holland & Knight, LLP, confirming that Escrow Agent may release the City's Escrow Documents from escrow upon Escrow Agent's disbursement of the Funds in accordance with the Closing Statement and Escrow Agent's distribution/recordation of the Closing Documents to the appropriate parties; and
2. Escrow Agent has been authorized by Developer to release the Funds and Developer Escrowed Documents from escrow, and Escrow Agent disburses the Funds in accordance with the Closing Statement.

V. Following Escrow Agent's satisfaction of the requirements set forth in Section IV above, Escrow Agent shall take the following actions:

1. Assemble counterparts of each of the Closing Documents executed by multiple parties;
2. Submit for recording the original recordable Closing Documents in the appropriate order, as directed by the City; and
3. Deliver the original Closing Documents to the appropriate parties.

VI. In the event that the Phase I Closing is not consummated by _____, Escrow Agent shall contact the City's counsel, Peter M. Friedman of Holland & Knight, LLP, and await further instructions.

[SIGNATURE PAGE FOLLOWS]

IN WITNESS WHEREOF, this Escrow Agreement is executed on the date first set forth above.

CITY OF CHICAGO, an Illinois home rule municipality

By: _____

Name: _____

Title: _____

EC 42 DEVELOPER LLC, an Illinois limited liability company

By: _____

Name: _____

Title: _____

NEAR NORTH NATIONAL TITLE, LLC, a Delaware limited liability company

By: _____

Name: _____

Title: _____

EXHIBIT L

STREETERVILLE THORIUM MONITORING AREA

Lindsay Light Streeterville Thorium Monitoring Area

Disclaimer. This map is for illustrative purposes only, does not accurately depict legal surveys or descriptions, and is subject to change. The information described and depicted includes areas undergoing investigations and cleanups. This map may contain errors, omissions, or positional inaccuracies, and should not be relied upon to confirm or refute the presence of thorium contamination. To confirm the information depicted, contact EPA Region 5, Emergency Response:
 Verneta Simon (312) 886-3601 or
 Dan Haag (312) 886-6906 or
 Gene Jablonowski (312) 886-4591.

1. 181 East Grand (Lindsay Light I, Known Contamination Removed) †
2. 160 East Illinois
3. 201-205 East Grand
4. 211 East Grand *
5. 215 East Grand
6. 200 East Illinois
7. 245 East Ohio
8. 600 North Fairbanks (aka Columbus Drive)
9. 164 East Grand *
10. 550 North St. Clair
11. 150-160 East Ontario
12. 240 East Ontario
13. 635 North Fairbanks (aka Columbus Drive)
14. 630 North McClurg
15. 600 N. Lake Shore Drive
16. Jane Addams Memorial Park
17. 515 North Peshtigo *
18. 455 East Illinois/400 East Illinois/510 North Peshtigo
19. 545 N McClurg ††
20. 341-355 East Ohio
21. 316 East Illinois (Lindsay Light II)
22. 465 North Park (No Surface Contamination)
23. 455 North Park *
24. Riverview & Promenade
25. Former Calatrava Spire property
26. DuSable Park (No Surface Contamination) *
27. Lake Shore East **
28. 130 East Lake
29. 22 West Hubbard (Lindsay Light III) †
30. Alley between 161 East Grand and 160 East Illinois
31. 600 East Grand ††
32. 636 North Michigan
33. Between Illinois & Ogden Slip/Navvy Pier Flyover Bridge
34. Beverly Gravel - 2900 Beverly Road.
 * Hoffman Estates (Not Shown) *
35. 500-598 East Illinois Street
36. 224-228 East Ontario
37. London House - 360 North Michigan



Note: This map does not present investigation information for the right-of-ways. This information can be obtained from <https://www.epa.gov/lindsay-light>

The Thorium Monitoring Area encompasses all buildings and rights-of-ways within the three areas depicted north and south of the Chicago River. Where a boundary line runs along a street, thorium monitoring is required for the properties within the boundary line and for any sidewalks adjacent to the boundary line.

Legend

- Thorium Monitoring Area
- Investigated/No Contamination
- Excavated Contamination Removed
- Ongoing Investigation and/or Cleanup
- Scan Indicated No Surface Contamination

*Deed restriction required due to uninvestigated or known contamination areas.
 **All surface contamination removed. Multiple properties within area have been cleaned up.
 †Demolition monitoring required.
 ††Thorium and Asbestos contamination present.



EXHIBIT M

STREETERVILLE FORM CDPH.ROW.03



DEPARTMENT OF PUBLIC HEALTH
CITY OF CHICAGO

FORM NO. CDPH.ROW.03 (STREETERVILLE Right-of-Way)

Notice is hereby given that the site you have requested a permit for is recorded with the City of Chicago Department of Public Health (CDPH) as potentially having environmental contamination on the site and adjacent right-of way. This environmental contamination could present a threat to human health and safety in connection with work performed at the site, or in the adjacent right-of-way, if proper safeguards are not employed.

A file containing detailed information regarding the aforementioned environmental contamination is available for review at CDPH at 333 S. State St., Room 200, Chicago, Illinois 60604 during normal business hours (8:30AM-4:30PM, Monday through Friday). Contact (312) 745-3152 for an appointment. This file must be reviewed and the remainder of this form completed before the permit can be issued if the ground is exposed or excavated. **Please note that for some locations, additional health and safety procedures may be required by law.**

Please complete the following:

I have reviewed and understand the documents, maintained by CDPH, regarding environmental contamination of the site and adjacent right-of-way. Further, I will ensure that all work at the subject site and adjacent right-of-way, and any monitoring required including but not limited to radiation monitoring, will be performed in a manner that is protective of human health and the environment and in compliance with all applicable local, state, and federal laws, rules, and regulations, especially those pertaining to worker safety and waste management. I will ensure that the results of any radiation monitoring and/or surveying conducted shall be provided to the CDPH and the United States Environmental Protection Agency **within two (2) weeks of their completion**. If any elevated levels of radioactive material are detected, I will immediately contact the United States Environmental Protection Agency at (800) 424-8802.

Applicant Name (print): _____ Signature: _____

Site Address and Work Location (Describe exact site location and **attach map**): _____

Nature of Work: _____

Company Name, Address, Phone No.: _____

General / Prime Contractor Name, Address, Phone No.: _____

Include subcontractor information if applicable)

Safety Officer / Phone No. _____

Radiation Contractor / Phone No. (if applicable) _____

Check if City Department Work Department Name: _____

CDOT Permit No.: _____

Today's Date: _____ Expected Start Date: _____ CDPH Approval / Date _____

Please return this completed form to the Chicago Department of Transportation, Division of Infrastructure Management, Public Way Permit Office, City Hall – Room 905, 121 N. LaSalle St., Chicago, Illinois 60602 during normal business hours (8:30 AM - 4:30 PM, Monday through Friday)

For CDPH Use Only

EXHIBIT N

CHICAGO SUSTAINABLE OPERATIONS PLAN

CITY OF CHICAGO **SUSTAINABLE** OPERATIONS PLAN

APRIL 2015



CITY OF CHICAGO



MESSAGE FROM OUR CHIEF SUSTAINABILITY OFFICER

Dear Colleagues,

Almost three years ago, Mayor Emanuel launched the Sustainable Chicago 2015 Action Agenda, which offers concrete initiatives, metrics and strategies to help make Chicago the most sustainable city in the country. Sustainable Chicago 2015 outlines the specific challenges we face. Most importantly, however, it explores the opportunities we can realize when we work together to make Chicago a healthier, more livable and prosperous place.

The City, with more than 425 leased and owned facilities, 11,000 pieces of equipment and vehicles and over 30,000 employees, is in a distinct position to have a broad and significant impact on achieving our goals. Conducting our daily operations in a sustainable manner will reduce hazardous chemical use in City facilities through our green cleaning program, reduce water consumption by installing water efficient fixtures, and improve air quality and reduce emissions by converting to a sustainable fleet. This plan and related policies share specific goals and actions related to health and safety, energy efficiency, waste and recycling, sustainable purchasing, water conservation and a sustainable fleet.

All City of Chicago employees can integrate sustainable actions into our daily work and help make Chicago a better city for everyone. Together, Chicago's sustainable and responsible execution of these day-to-day efforts that keep our City moving now, will ensure it keeps moving for generations to come.

Sincerely,



Karen Weigert
Chief Sustainability Officer



TABLE OF CONTENTS

MESSAGE FROM OUR CHIEF SUSTAINABILITY OFFICER	ii
REVISION HISTORY	iv
SECTION 1: INTRODUCTION.....	1
1.1 Purpose and Scope.....	1
1.2 Associated Plans and Policies.....	1
1.3 Plan Organization	2
SECTION 2: GOALS AND RESPONSIBILITIES	3
2.1 Sustainable Operations Goals	3
2.2 Responsibilities.....	3
2.2.1 All Employees	3
2.2.2 Management.....	3
SECTION 3: ALL EMPLOYEES/DEPARTMENTS	5
SECTION 4: FACILITY OPERATIONS.....	7
SECTION 5: FLEET AND FUELING	10
SECTION 6: ARCHITECTURE, ENGINEERING AND CONSTRUCTION	11
APPENDIX A: TONER AND INK CARTRIDGE RECYCLING INSTRUCTIONS	13



REVISION HISTORY

The following table describes changes made to this *Sustainable Operations Plan*. This Plan may be revised as necessary to remain current with applicable regulations, technologies and practices. Entries should be made to the table below as information is added or revised.

Date	Revision	Description
04/20/15	0	Initial Issue



SECTION 1: INTRODUCTION

1.1 Purpose and Scope

To lead by example, the City of Chicago has developed this *Sustainable Operations Plan* for conducting day-to-day operations at City facilities in a sustainable manner. It provides actions for management, employees, and departments to implement as part of their daily operations. This plan intends to remind departments to make environmentally conscious decisions and to integrate sustainability measures as a standard practice into everything we do.

This Plan addresses seven categories critical to operating sustainably:

1. **Health and Safety**
2. **Energy Efficiency**
3. **Waste and Recycling**
4. **Sustainable Purchasing**
5. **Water Conservation**
6. **Transportation**
7. **Climate Change**

1.2 Associated Plans and Policies

This Plan incorporates many of the elements of the policies and programs prepared by the Department of Fleet and Facility Management (2FM) for LEED (Leadership in Energy & Environmental Design) for Existing Building Operations and Maintenance (EBOM) certification. They include:

- Building Exterior and Hardscape Management Plan
- Erosion Control and Landscape Management
- Construction Indoor Air Quality Management Plan
- Green Cleaning Policy and Program Plan
- Integrated Pest Management Plan
- Plug Load Reduction Policy
- Sequence of Operations Plans (Building Specific)
- Solid Waste Management Policy
- Sustainable Purchasing Policy
- Water Efficiency Economic Assessment Policy
- Cooling Tower Water Management Plan

The current versions of these plans and policies can be found on the 2FM Intranet site. If a department has a more stringent policy than what is required by this Plan, then the department policy takes precedent.

In addition to the above policies and programs, *Sustainable Chicago 2015* serves as a guiding document. *Sustainable Chicago 2015* builds upon the Chicago Climate Action Plan (CCAP), which calls for reducing greenhouse gas emissions by 80% by 2050 and preparing the city for impacts to climate change. *Sustainable Chicago 2015* accelerates progress towards the CCAP goals and establishes specific initiatives for both the public and private sector. Implementation of a sustainable operations plan for City facilities is identified as a key action for **Goal 21: Incorporate Standard Green Practices in all City Operations.**



1.3 Plan Organization

The Plan consists of six sections, organized by particular audience or operation for implementation of this plan:

Section 1: Introduction

Section 2: Goals and Responsibilities

Section 3: All Employees

Section 4: Facility Operations (Zone Managers, Operating Engineers and Construction Trades)

Section 5: Fleet and Fueling

Section 6: Design, Engineering and Construction

The Plan is owned and managed by 2FM. For support, comments, or corrections, please consult with 2FM's Bureau of Environmental, Health and Safety Management (EHS).



SECTION 2: GOALS AND RESPONSIBILITIES

2.1 Sustainable Operations Goals

Implementation of this Plan will advance the City's following sustainability goals*:

- **Focus on the Safety and Health of Employees:** Prioritize and improve worker safety through employee training and accident prevention.
- **Improve Energy Efficiency:** Improve overall energy efficiency in City buildings by 10% annually, double the number of LEED-certified public buildings, target 10 million square feet of municipal buildings for an energy reduction of 20% and install 10 MW of renewable energy on City properties.
- **Improve Waste Reduction and Recycling:** Conserve natural resources and divert waste from landfills, make as many City processes as paperless as possible, and divert 75% of eligible municipal construction waste.
- **Adopt Sustainable Purchasing:** Reduce resource consumption and waste by prioritizing the purchase of post-consumer, post-industrial, locally-sourced, Energy Star labeled and organic products. Each department has unique needs and opportunities for sustainable purchases and it is management's responsibility to identify and educate staff on what is required and available for use.
- **Improve Water Conservation:** Implement and pilot water use reduction and conservation strategies and track and report water use in City facilities.
- **Create a Sustainable Fleet:** Reduce municipal fossil fuel consumption by 10%, reduce the number of vehicles in the City's fleet and replace 3% of on-road fleet vehicles with green fleet annually.
- **Reduce greenhouse gas emissions and improve air quality:** All the goals described above will contribute to a reduction in greenhouse gas emissions and many will help improve air quality.

**Numeric goals are from Sustainable Chicago 2015 Action Agenda*

2.2 Responsibilities

2.2.1 All Employees

All City of Chicago employees have the responsibility of being familiar with this plan, identifying the sections applicable to their work and integrating sustainable actions into their daily operations. **Section 3** provides specific actions applicable to all employees.

2.2.2 Management

Each City department has unique opportunities and different areas of focus associated with achieving the sustainable operations goals and leading by example. Management should be familiar with all aspects of this Plan and associated policies, and should continue to identify sustainable operations measures applicable to their Department's area of impact.



It's the responsibility of management (Commissioners, Deputy Commissioners, and Supervisors etc.) to:

- Endorse and support the Plan;
- Provide opportunities for staff to be trained on key aspects of the Plan;
- Develop a culture of sustainability awareness;
- Require implementation of this Plan by their staff; and
- Assign staff to monitor and track progress as required by the associated plans and policies.



SECTION 3: ALL EMPLOYEES/DEPARTMENTS

This section applies to all City of Chicago employees and provides actions and reminders of how to operate sustainably, regardless of where you work or what you do.

Applicable Policies:

- Plug Load Reduction Policy
- Solid Waste Management Policy
- Sustainable Purchasing Policy

Be Healthy and Safe

- Periodically review and update your Job Hazard Analysis to ensure it remains current and continues to help reduce workplace accidents and injuries.
- Identify and mitigate safety risks and hazards prior to starting work.
- Stop work and notify your supervisor if you observe unsafe working conditions.
- Complete all required health and safety training.

Improve Energy Efficiency

- Remove personal electronic appliances, including microwaves and refrigerators, as they are not allowed. Appliances in common areas for all to use are allowed.
- Remove personal electric space heaters, as they are not allowed except for in the case of long-term system malfunctions and as authorized and provided by 2FM. Notify your building's Operating Engineer of any issues.
- Dress appropriately for the weather and keep a light sweater or jacket at work to help with temperature fluctuations. Temperatures in buildings will be maintained from 70° to 74° in the heating season and 72° to 78° in the cooling season.
- Turn-off lights in unoccupied spaces, such as offices and conference rooms.
- Turn-off computers and printers at the end of each work day.
- Unplug equipment that does not receive frequent usage such as a typewriter, pencil sharpener, coffee maker, etc.
- Unplug equipment once devices such as phones and camera batteries are fully charged.
- Turn-off clock radios and personal stereos at the end of each work day.
- Keep doors and windows closed in conditioned buildings.

Reduce, Reuse, Recycle

- Go paperless, and when printing or copying is necessary, make double-sided copies and print multiple pages on each side of a sheet.
- Create a scrap paper bin for notes or printing draft or internal copies.
- Use reusable cups, plates and silverware.
- Use designated recycling (paper, plastic, aluminum cans etc.) and garbage receptacles; notify your building's Operating Engineer if additional receptacles are needed.
- Familiarize yourself with your building's recycling criteria.
- Use EPA's *Waste Management Hierarchy* (right) and prioritize source reduction, reuse and recycling over disposal whenever possible.
- Use the resources provided in the following table before throwing something away.

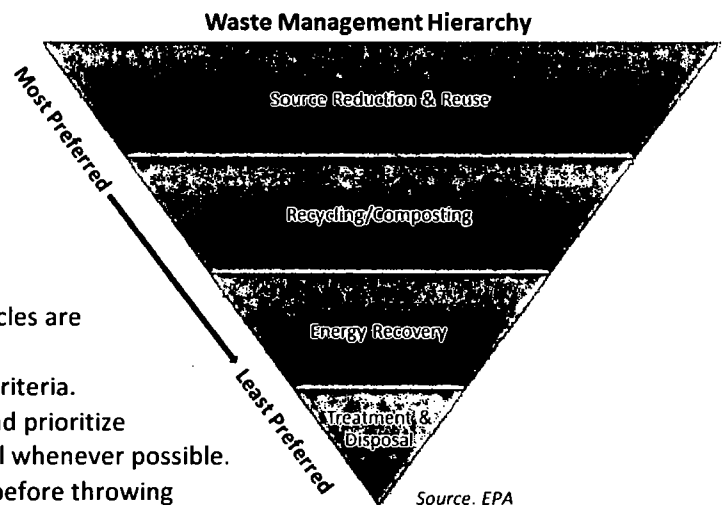

Material	Method
Furniture	Notify your building's Operating Engineer for potential reuse elsewhere.
Computer Hardware (PCs, laptops, monitors, printers)¹	Notify your department's Information Technology Strategy Committee (ITSC) or Department of Innovation and Technology.
Other Electronic Waste¹	Notify the building's Operating Engineer for potential consolidation and recycling.
Waste Toner	Place back in original box and collect until next service visit by Canon technician, who will remove the boxes
Empty Ink and Toner Cartridges	Recycle using Office Depot's Recycling Rewards Program (See Appendix A for Instructions).
Rechargeable Batteries²	Call2Recycle; Contact 2FM's EHS Bureau for a box or list of locations.
Office Supplies	If still usable, donate to Sister Agencies (such as Chicago Public Schools). Keep a record of all donations.
Other	Check http://www.earth911.com/recycling-center-search-guides/ for local resources and/or contact 2FM's EHS Bureau.

¹ Many electronics are banned from being landfilled. The complete list is here: <http://www.epa.illinois.gov/topics/waste-management/electronics-recycling/index>.

² Nickel Cadmium, Lithium Ion, Small Sealed Lead Acid, Nickel Metal Hydride, Nickel Zinc, and cellphone batteries. For more information visit: <http://www.call2recycle.org/what-can-i-recycle/>.

Buy Green

- Be familiar with the City's and your Department's (if available) Sustainable Purchasing Policy.
- Incorporate green purchasing requirements by reviewing and including applicable criteria specified in the US General Services Administration (GSA) Sustainable Facilities Tool at <http://sftool.gov/GreenProcurement>.
- Purchase food that is organic or locally produced; utilize restaurants and catering that support local farms and producers.
- Purchase ongoing consumables (such as printing and copying paper, envelopes, toner cartridges, etc.) that contain post-consumer or post-industrial content.

Use Water Wisely

- Turn off water when not in use.
- Use tap water and reusable bottles for drinking water instead of bottled water.
- Notify your building's Operating Engineer of potential leaks and leaky faucets.
- Notify your building's Operating Engineer of any spills of hazardous materials, e.g., cleaning agents, toner.

Travel Savvy

- Use Flex Fleet, the City-wide pool vehicle sharing, or Zipcar for trips not within walking distance.
- Practice eco-driving (See http://www.chicagoclimatereaction.org/pages/eco_driving_practices/90.php for more information).
- Reduce idling and follow the Vehicle Idling Management Policy (Section 9-80-095 of the Chicago Municipal Code).
- Consolidate trips and carpool when possible.
- Continually evaluate and optimize routes.



SECTION 4: FACILITY OPERATIONS

This section applies to those positions responsible for the day-to-day operation of City facilities, including Zone Managers (ZM), Operating Engineers (OE) and Trades (T). Each item is applicable to one or more groups as noted.

Be Committed to Safety in your Building

- Identify potential safety hazards and address them with your supervisor. (ALL)
- Mitigate recognized safety hazards through elimination, substitution, engineering controls, warnings, administrative controls, or use of personal protective equipment (e.g., eliminate the need to enter confined spaces such as vaults whenever possible). (ALL)
- Complete all required health and safety training, including additional training required when working at heights, performing lockout/tagout, conducting hot work, performing a confined space entry, excavating, and when there exists a potential to be exposed to asbestos, lead, and bloodborne pathogens. (ALL)
- Use the appropriate tools and equipment for the job; inspect before use. (ALL)
- Inform tenants about jobs by using clear demarcation and/or barriers. (ALL)
- Anticipate potential indoor air quality problems before starting a job (ALL); follow the Construction Indoor Air Quality Management Plan. (T)
- Ensure contractors comply with all applicable policies, including but not limited to:
 - Building Exterior and Hardscape Management Plan (ZM, OE),
 - Green Cleaning Policy and Program Plan (ZM),
 - Erosion Control and Landscape Management Plan (ZM), and
 - Integrated Pest Management Plan (ZM).
- Provide timely and safe snow and ice removal. (ZM, OE)

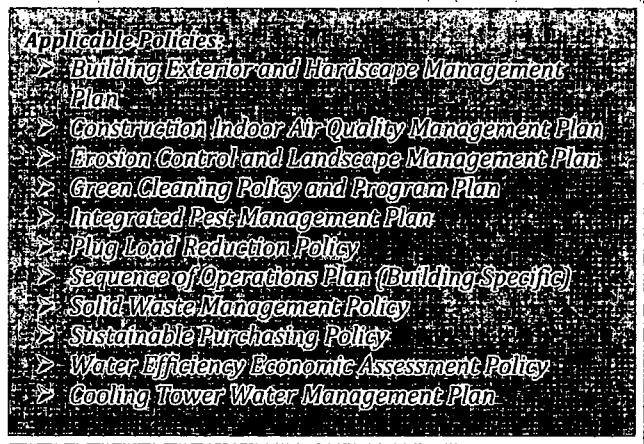

Improve Energy Efficiency

- Install occupancy sensors in low or sporadic traffic areas such as copy rooms, lunch rooms and bathrooms. (OE, T)
- Monitor compliance with personal appliance ban. (OE)
- Use supplemental electric heaters only during long-term system malfunctions. (OE)
- Verify lights and HVAC systems are scheduled to match building hours of operation. (OE)
- Phase out CFC-based equipment in HVAC systems. (OE)
- Maintain temperatures from 70° to 74° in the heating season and 72° to 78° in the cooling season. (OE)
- Ensure that existing systems are operating per original design intent. (OE)
- Ensure that alternative energy systems (e.g., solar, geothermal) are maintained for optimum performance. (OE)
- Monitor the Building Automation System for trends as it relates to equipment run time. (OE)
- Identify major energy consumption sources and work with 2FM's Bureaus of Energy and Performance Improvement (EPIC) and Architectural, Engineering and Construction (AEC) to monitor power usage. (OE)
- Conduct preventative maintenance on HVAC systems such as regularly changing filters, cleaning chiller tubes, testing for leaks, etc. (OE)
- Notify your supervisor of aging electrical equipment where new equipment is more energy efficient. (OE, T)



Reduce, Reuse, Recycle

- Equip your building with proper receptacles for the collection of recyclables (paper, plastic, aluminum cans etc.) and garbage. This includes desk side and common areas. Wherever you have a garbage receptacle there should also be a recycling receptacle, and vice-versa. (ZM)
- Post information about what materials can be recycled near the recycling receptacles. (ZM, OE)
- Properly dispose of all waste materials, including unspent or outdated products. Only order what is needed now. (ALL)
- Recycle a minimum of 75% of eligible construction debris for demos, new construction, alterations, and additions. (T)
- Reduce salt usage in snow removal practices.(ZM)
- Use EPA's *Waste Management Hierarchy* (right) and prioritize source reduction, reuse and recycling over disposal whenever possible. Use the resources in the following table before throwing something away or down the drain. (ALL)
- Phase out chlorofluorocarbon (CFC) refrigerant use and minimize refrigerant leaks in air conditioning equipment and chillers. (OE)

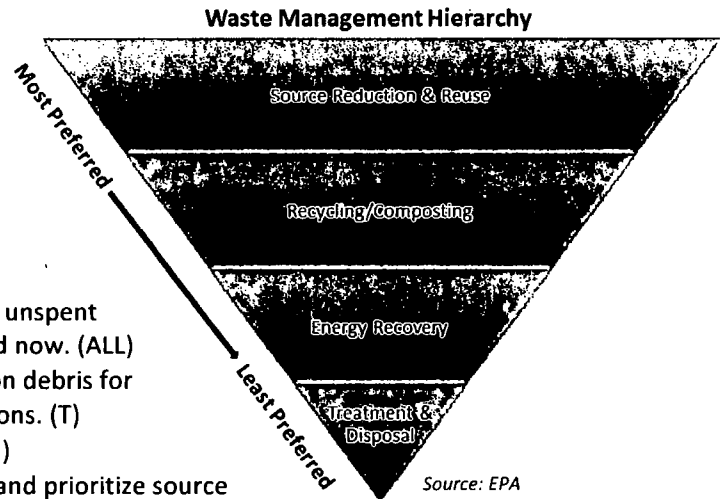

Material	Method
Furniture	Notify your building's Operating Engineer for potential reuse elsewhere.
Computers	Notify your department's Information Technology Strategy Committee (ITSC) or Department of Innovation and Technology.
Other Electronic Waste ¹	Notify your building's Operating Engineer or EHS Bureau and potentially consolidate for pick-up from contractor.
Waste Toner	Place back in original box and collect until next service visit by Canon technician, who will remove the boxes.
Empty Ink and Toner Cartridges	Recycle using Office Depot's Recycling Rewards Program (See Appendix A for Instructions).
Rechargeable Batteries ²	Call2Recycle; Contact 2FM's EHS Bureau to receive a box or for a list of existing locations.
Universal Waste ³	Refer to the Universal Waste Management Standard Operating Procedure.
Chemicals/Unknown/ Hazardous Waste	Contact 2FM's EHS Bureau.
Office supplies	If still usable, donate to Sister Agencies (Such as Chicago Public Schools). Keep a record of all donations.
Other	Check http://www.earth911.com/recycling-center-search-guides/ for local resources and/or contact 2FM's EHS Bureau.

¹ Many electronics are banned from being landfilled. The complete list is here: <http://www.epa.illinois.gov/topics/waste-management/electronics-recycling/index>.

² Nickel Cadmium, Lithium Ion, Small Sealed Lead Acid, Nickel Metal Hydride, Nickel Zinc, and cellphone batteries. For more information visit: <http://www.call2recycle.org/what-can-i-recycle/>.

³ Includes fluorescent light bulbs, batteries not included in the Call2Recycle program, mercury-containing equipment and pesticides.

Adopt Sustainable Purchasing

- Identify and incorporate requirements for green purchasing and practices as new contracts come up (such as janitorial, consumables, pest control and refrigerant management). (ALL)



Adopt Sustainable Purchasing

- Identify and incorporate requirements for green purchasing and practices as new contracts come up (such as janitorial, consumables, pest control and refrigerant management). (ALL)
- Require that conventional gas-powered equipment is replaced with electric (such as maintenance and cleaning equipment, lawn mowers, snow and leaf blowers, etc.) when practical. (ZM)
- Purchase and install electronics and appliances that are Energy Star labeled. (T)
- Purchase ongoing consumables that contain post-consumer or post-industrial content. (ALL)
- Be familiar with green purchasing options available and purchase products for repairs and maintenance that meet product-specific sustainable criteria (e.g., carpeting, caulk, roofing materials, insulation) available at <http://sftool.gov/GreenProcurement>. (ALL)

Improve Water Conservation

- Replace older plumbing fixtures; replacements should meet or exceed UPC/IPC Standards and EPA's WaterSense Standards when possible. (T)
- Install aerators on faucets. (T)
- Turn off water when not in use; don't let it run. (ALL)
- Report (ALL) and repair (OE, T) potential leaks and leaky faucets promptly.
- Report any spills of hazardous materials to EHS immediately; confine spill to prevent reaching the sewer or surface waters. (ALL)

Be Smart when Traveling (ALL)

- Use Flex Fleet, the City-wide pool vehicle sharing, or Zipcar for trips not within walking distance.
- Practice eco-driving (See http://www.chicagoclimatereaction.org/pages/eco_driving_practices/90.php for more information).
- Reduce idling and follow the Vehicle Idling Management Policy (Section 9-80-095 of the Chicago Municipal Code).
- Consolidate trips and carpool when possible.
- Continually evaluate and optimize routes.



SECTION 5: FLEET AND FUELING

The section applies to the operation, replacement, and maintenance of the approximately 6,600 motor vehicles included in the City's fleet.

Drive Smart

- Reduce idling and follow the Vehicle Idling Management Policy (Section 9-80-095 of the Municipal Code).
- Consolidate trips.
- Continually evaluate and optimize routes.
- Practice eco-driving (See http://www.chicagoclimatereaction.org/pages/eco_driving_practices/90.php for more information).

Be Healthy and Safe

- Periodically review and update your Job Hazard Analysis to ensure it remains current and continues to help reduce workplace accidents and injuries.
- Use the appropriate tools and equipment for the job; inspect before use.
- Identify and mitigate safety risks and hazards prior to starting work.
- Stop work and notify your supervisor if you observe unsafe working conditions.
- Complete all required health and safety training.
- Train employees on safe driving techniques and fueling practices.

Create a Sustainable Fleet*

- Replace 3% of on-road fleet vehicles with green fleet annually.
- Reduce the number of vehicles in the City's fleet through Flex Fleet, City-wide pool vehicle and Zipcar.
- Continue preventative maintenance and regular maintenance to ensure operation of existing fleet.
- Reduce fuel consumption by 10%.
- Use biodiesel during warm weather months.

Reduce Waste and Recycle

- Minimize chemical use at fueling stations and maintenance shops.
- Implement spill prevention controls outlined in Spill Prevention, Control, and Countermeasure (SPCC) plans at fueling stations and maintenance shops.
- Recycle used oil and used oil filters, batteries, spent engine coolant, refrigerants, spent solvent and tires.
- Use aqueous parts washers instead of solvent parts washers.
- Choose vehicle washing facilities that use biodegradable soaps, minimize detergent use, and employ water conservation measures (e.g., installing water-efficient equipment; detecting and repairing leaks; adjusting nozzle alignment, timing and flow rates).
- Use automotive paints and primers with low or no volatile organic compounds (VOCs) and hazardous air pollutants (HAPs) when available and when it will not impact performance.
- Incorporate green purchasing requirements for general maintenance products (such as lubricants, coolants, cleaning agents, oil, sorbents, etc.) by reviewing and including applicable criteria specified in the US General Services Administration (GSA) Sustainable Facilities Tool at <http://sftool.gov/GreenProcurement>.
- Use reclaimed engine coolants and re-refined oils when cost effective and when it will not void manufacturer's warranty.

**Numeric goals are from Sustainable Chicago 2015 Action Agenda*



SECTION 6: ARCHITECTURE, ENGINEERING AND CONSTRUCTION

This section applies to the design, construction and engineering of all City facilities. This plan should be applied to all projects designed and implemented by 2FM and when completed by others (such as the Public Building Commission, contractors, vendors, etc.).

As applicable, these measures should be utilized for both new construction projects and rehabilitation of existing facilities and applied to both the interior and exterior as appropriate. At a minimum, it is the City's policy to obtain LEED-NC Silver certification for new construction and LEED and/or LEED-CI (Commercial Interiors) Silver certification for major renovations.



As applicable, these measures should be utilized for both new construction projects and rehabilitation of existing facilities and applied to both the interior and exterior as appropriate. At a minimum, it is the City's policy to obtain LEED-NC Silver certification for new construction and LEED and/or LEED-CI (Commercial Interiors) Silver certification for major renovations.

Understand the User's Needs

- Identify and understand the needs, requirements, goals, owner and user for each project.
- Estimate the project's operating life expectancy and incorporate measures for post-use flexibility.
- Consider how design choices impact users, such as how layout or material selections affect their productivity, comfort, operating costs, etc.
- Communicate the project's design features and provide instructions for optimal use to the user. This could include explaining the importance and providing the optimal settings for humidity, lighting, ventilation and environmental controls, identifying low- and no-VOC materials used and providing care and maintenance instructions as applicable.

Design with Safety in Mind

- Identify and mitigate recognized safety hazards through elimination, substitution, engineering controls, warnings, administrative controls or use of personal protective equipment (e.g., eliminate confined spaces such as vaults whenever possible).
- Anticipate potential indoor air quality problems for facility alterations and additions; follow the Construction Indoor Air Quality Management Plan.
- Allow for well-defined separation between work and construction areas, including material transfer corridors, e.g., plastic sheeting, barriers.

Improve Energy Efficiency

- Identify and implement energy efficiency retrofit projects and grants for City facilities; document results using available building-level energy data.
- Continue to track energy use through the USEPA/USDOE's Energy Star Portfolio Manager to identify energy use trends and opportunities for increased energy efficiency.
- When upgrading equipment in existing buildings, assess and document what is already in place.
- Incorporate renewable energy sources into facilities, when possible.
- Eliminate use of chloroflorocarbon (CFC)-based refrigerants when installing new or replacing existing HVAC systems.
- Provide ongoing training and equipment schedules for new or improved HVAC systems to operating engineers.
- Ensure that existing systems are operating per original design intent by consulting the building's Sequence of Operations Plans and Systems Manual.



- Evaluate need for periodic re-commissioning, especially if there is a sudden or unexplained change in energy usage.
- Ensure that alternative energy systems (e.g., solar, geothermal) are maintained for optimum performance.
- Monitor the Building Automation System for trends as it relates to equipment run time.
- Set back equipment during unoccupied times (such as at night) to reduce energy use.
- Light exterior areas only as required for safety and comfort to support light pollution reduction.
- Incorporate use of natural daylighting strategies.
- Install ultra-reflective roofs.

Reduce, Reuse, Recycle

- Equip facilities with proper infrastructure and space for the collection of recyclables and garbage.
- Utilize pre-fabricated building components where available and practicable.
- For renovations, reuse as much material as possible and auction materials that are still useful but no longer needed.
- Exceed 75% recycling of eligible demolition and construction debris for new construction and major alterations and additions.
- For new sites, select brownfields when possible to promote their remediation and reuse.
- Manage excavated soils on site where possible. Characterize site soils to determine appropriate uses and disposal requirements; incorporate into specs.

Adopt Sustainable Purchasing

- Reuse existing furnishings when possible.
- Purchase furnishings that contain post-consumer or post-industrial content, or are locally sourced, or have been previously used.
- Use no-VOC or low-VOC, environmentally friendly products for all paints and sealants.
- Purchase electronics and appliances that are Energy Star labeled.
- Purchase products for alterations and additions that meet product-specific sustainable criteria.
- Choose roofing made from recycled materials.
- Be familiar with green purchasing options available and choose materials that meet product-specific sustainable criteria (e.g., carpeting, caulk, roofing materials, insulation) available at <http://sftool.gov/GreenProcurement>.

Improve Water Conservation

- Evaluate water reduction strategies and fixture upgrades according to the Water Efficiency Economic Assessment Policy.
- Fixtures should meet or exceed UPC/IPC Standards and EPA's WaterSense Standards when possible.
- Where irrigation is needed and when feasible, incorporate onsite above-grade rainwater collection and distribution systems.
- Meet or exceed installation of green roof on 25% of available roof area on new construction buildings.
- Utilize techniques to manage stormwater on-site and reduce impervious areas, such as installing permeable pavement or green roofs.
- Use low-maintenance and native plantings in exterior landscaped areas.
- Provide plans for ongoing landscape management.

Encourage a Sustainable Fleet

- Locate new facilities near public transportation, Divvy, and Flex Fleet options.



APPENDIX A: TONER AND INK CARTRIDGE RECYCLING INSTRUCTIONS



My Business Recycles Program



Ink and Toner Recycling Website: www.mybusinessrecycles.com



CLICK HERE

Shop at Office Depot

Welcome, Tina (Not me?) | [Logout](#)

[Home](#) [Register](#) [Login](#) [Contact Us](#)



Recycling can be rewarding
for your business

Get reimbursed
for your ink & toner cartridges



It's as simple as 1-2-3

1 STEP 1
Provide your details in the form

2 STEP 2
Print **FREE** pre-paid UPS shipping labels or
order **FREE** collection boxes



Login

Email Address

Required

Password

Remember Me

[Forgot your login name / password?](#)

[Terms & Conditions](#)

[Privacy Policy](#)

Login

My Account



My Account

This year, my b
with Office Dep
rewards, click h

Order Recycling Supplies

Pallet Pickup

Reports

Current User: tinas@cloverttech.com
Company: Clover Technologies
Your Account Status: Active
Number of Locations: 4
Number of Users: 2

Change Password [Change Password](#)

Order Recycling Supplies

- Pallet Pickup
- Reports
- Program Information
- Locations
- Users
- Change Password

Shopping Cart

Total in Cart: 0 [View Cart](#)

Users

1: Choose a shipping location

2: Your Shopping Cart Supplies

3: Order

1: Please select a product from below

Ink Cartridge Shipping Label

Description:
Use a box less than 130 inches when calculated as Length + 2x Width + 2x Height. Pack the items carefully. Use bubble wrap or old newspaper to separate the cartridges from one another.



Qty: 1

Toner Cartridge/Fuser Shipping Label

Description:
Use a box less than 130 inches when calculated as Length + 2x Width + 2x Height. Pack the items carefully. Use bubble wrap or old newspaper to separate the cartridges from one another.

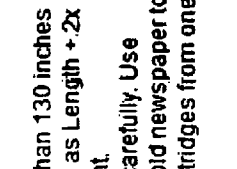

Qty: 1

Laser Toner/Fuser Container

Description:
Pre-paid label included
Box Size: 20"x20"x22"
Capacity: Holds 8-10 cartridges

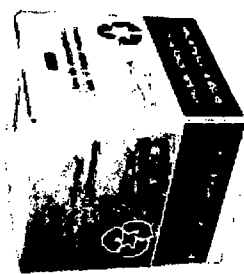

Qty: 1

Desktop Inkjet Container

Description:
Pre-paid label included
Box Size: 9"x15"x9.5"
Capacity: Holds approximately 35 inkjet cartridges

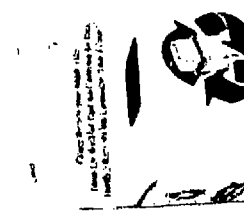

Qty: 1

Desktop Cell Phone Container

Description:
Pre-paid label included!
Box Size: 8.75"x18.75"x14.25"
Capacity: Holds approximately 25

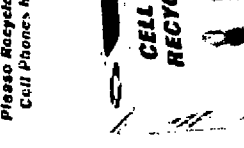

Qty: 1

Desktop Cell Phone Container

Description:
Pre-paid label included!
Box Size: 8.75"x18.75"x14.25"
Capacity: Holds approximately 25



Qty: 1



Pallet PickUp

This year, my business has earned \$0.00 by recycling with Office Depot. For more information about your rewards, [click here](#).

Shopping Cart

Total in Cart: 0 [View Cart](#)

Order Recycling Supplies

My Business

Reports

Locations

Users

Contact Name

Email

Contact Phone

Ship To Code

Customer No.

Address

City

State / Province

Country

Zip / Postal Code

Maximize your returns by accumulating at least one pallet of OEM cartridges (100 laser toner and/or 6-8 large ink boxes) before scheduling a pickup.

You'll receive an email confirming the pickup with the bill of lading and pallet label prior to the carrier arriving. In most cases, our carrier will pick up the pallets within 3 business days. If the carrier doesn't make the pick up on the scheduled date, please contact us immediately at palletpickup@MyBusinessRecycles.com or you can reach us by phone at 1-855-821-2335.

Step 1: Locations

Number of Pallets

Pickup Date

Hours

Time zone

Instructions

Does your Location have a dock?

Label / Door

From:

To:

Send



My Account > Track Activity

Track Activity

This year, my business has earned \$0.00 by recycling with Office Depot. For more information about your rewards, [click here](#).

Shopping Cart

Total in Cart: 0 [View Cart](#)

Order Recycling Supplies

Pallet Pickup

Locations

Users

Select the reporting timeframe for your report and click search. (Data is current up to two days ago and is available for the past 18 months.)

Once your report has run and you see the data, you can filter it by typing or selecting a value in one or more of the filter fields located under the column names.

Click the "+" sign next to any data to see more detail. To view your data in Excel, click the Export button.

From To

Company Name	Description	#	Ship to Code	Date	Tracking #	OEM/Reman	Condition	Qty	Unit Price	Total Reward
No data to display										
										Total Qty:
										Total:



My Account > Program Information

Program Information

This year, my business has earned \$0.00 by recycling with Office Depot. For more information about your rewards, [click here](#).

Shopping Cart

Total in Cart: 0 [View Cart](#)

Order Recycling Supplies

Pallet Pickup

Reports

Locations

Users

Click the files below for additional information about our My Business Recycles program. If you have any questions, please click the "Contact Us" link.

Name	Files
Protecting Data on Wireless Devices	file
Environment White Paper	file
Cartridge Buyback List	file
Cell Phone Buyback List	file
Fuser Buyback List	file
Pallet Pickup Instructions	file
Packaging Instructions	file
Program Overview	file
ISO 9001 - Ink Recycling	file
ISO 9001 - Toner Recycling	file



[CLICK HERE](#)

My Account > Users



Shopping Cart

Total in Cart: 0 [View Cart](#)

This year, my business has earned \$0.00 by recycling with Office Depot. For more information about your rewards, [click here](#).

[Order Recycling Supplies](#)

[Pallet Pickup](#)

[Reports](#)

[Locations](#)

[USDTG](#)

You can add additional users who can order supplies or request pallet pick ups by setting their user type to "User Admin". If you set their user type to "Report Viewer", they will only be able to view recycling activity reports.

NOTE: Additional users will be able to view all of the "Ship To" locations on your account.

You can use the boxes under the words First Name, Last Name, etc. to filter your list.

[Click to Add New User](#)

Drag a column header here to group by that column

#	First Name	Last Name	Login Date	User Type	Status
Edit	Delete	Tina	Smith	User Admin	Active



[CLICK HERE](#)

Welcome, Tina (Not me?) | [Logout](#)

[Home](#) [My Account](#) [Logout](#) [Contact Us](#) [Admin](#)

[My Account](#) > [Locations](#)



Locations

This year, my business has earned **\$0.00** by recycling with Office Depot. For more information about your rewards, [click here](#).

Shopping Cart

Total in Cart: 0 [View Cart](#)

[Order Recycling Supplies](#)

[Pallet Pickup](#)

[Reports](#)

[Users](#)

A "Ship To" location is where MyBusinessRecycles will send FREE recycling supplies and/or pick up pallets of empty printer cartridges and cell phones.

You can use the fields under the words Company, Address 1, etc. to filter your list.

Click Edit to change information about a "Ship To".

[Click to Add New Location](#)

Drag a column header here to group by that column

Type to start filter	Company	Address 1	City	State	Ship To Code	Contact Name	Status
Clear							Active
Edit	Clover Technologies	4200 Columbus St	Ottawa	Illinois	12345678	Tina Smith	Active
Edit	Clover	12345 Test St	Ottawa	Illinois	61350	Tina S	Active
Edit	Tina S	12345 Sample St	Ottawa	Illinois	SAMPLE	Tina Smith	Active
Edit	Clover	4200 Columbus St	Ottawa	Illinois	12345	Tina Smith	Active

EXHIBIT O

FIREHOUSE CONSTRUCTION DOCUMENTS

EXHIBIT P

PUBLIC IMPROVEMENTS

1. Street Repaving and restriping:
 - A. Dearborn Street from Hubbard Street on the South to Illinois Street on the north.
 - B. Illinois Street from Clark Street on the west to Dearborn Street on the east. The restriping shall include a new Contra-flow Fire Lane on the north side of Illinois Street between Clark Street and the Hyatt Place driveway.
2. New sidewalk installation:
 - A. Dearborn Street form Hubbard Street on the South to Illinois Street on the north.
 - B. Illinois Street from Clark Street on the west to Dearborn Street on the east.
3. Traffic Signals:
 - A. Upgrade traffic signals at the intersections of Illinois Street and Dearborn Street and Illinois Street with Clark Street to include cable, conduit and other necessary equipment for installation of push button preemption that will be installed within the New Firehouse for emergency vehicles.
 - B. During the design phase of the New Firehouse, the City and Developer will continue to work toward a mutually agreeable solution for the Chicago Fire Department vehicles to travel westbound on Illinois Street to Clark Street (“Contra Flow Lane”) in a form and substance approved by the Commissioner of the Department of Transportation as part of the New Firehouse Design Documents. These shall include, but are not limited to, traffic signal indications, poles, mast arms, ATC controllers, cables, conduits, trenching and restoration.

EXHIBIT Q

CONSTRUCTION SCHEDULE

[To be added]

EXHIBIT R









DELETED

EXHIBIT S









FURNITURE, FIXTURES, AND EQUIPMENT TO BE PURCHASED FOR FIREHOUSE

FF&E MATRIX

Engine Company 42
D.R. Cooney

Company	Engine Company 42 2615 West 46th Ave Aurora, CO 80015 Phone: 303-291-1800 Fax: 303-291-1800	
Company	Engine Company 42 2615 West 46th Ave Aurora, CO 80015 Phone: 303-291-1800 Fax: 303-291-1800	
Company's Chemistry	Standard for the engine is ASTM D 975. The engine is used for fire fighting.	
Company's Chemistry	Standard for the engine is ASTM D 975. The engine is used for fire fighting.	
Company's Chemistry	Standard for the engine is ASTM D 975. The engine is used for fire fighting.	
Company's Chemistry	Standard for the engine is ASTM D 975. The engine is used for fire fighting.	
Company's Chemistry	Standard for the engine is ASTM D 975. The engine is used for fire fighting.	
Company's Chemistry	Standard for the engine is ASTM D 975. The engine is used for fire fighting.	
Company's Chemistry	Standard for the engine is ASTM D 975. The engine is used for fire fighting.	
Company's Chemistry	Standard for the engine is ASTM D 975. The engine is used for fire fighting.	
Company's Chemistry	Standard for the engine is ASTM D 975. The engine is used for fire fighting.	

Engine Company 42
D.R. Cooney

Company's Chemistry	Standard for the engine is ASTM D 975. The engine is used for fire fighting.	
Company's Chemistry	Standard for the engine is ASTM D 975. The engine is used for fire fighting.	
Company's Chemistry	Standard for the engine is ASTM D 975. The engine is used for fire fighting.	
Company's Chemistry	Standard for the engine is ASTM D 975. The engine is used for fire fighting.	
Company's Chemistry	Standard for the engine is ASTM D 975. The engine is used for fire fighting.	
Company's Chemistry	Standard for the engine is ASTM D 975. The engine is used for fire fighting.	
Company's Chemistry	Standard for the engine is ASTM D 975. The engine is used for fire fighting.	
Company's Chemistry	Standard for the engine is ASTM D 975. The engine is used for fire fighting.	
Company's Chemistry	Standard for the engine is ASTM D 975. The engine is used for fire fighting.	
Company's Chemistry	Standard for the engine is ASTM D 975. The engine is used for fire fighting.	

Schematic Scope Documents

February 17, 2012

DRG Corp

FF&E MATRIX

Engine Company 42
Dut Creek











Wrench Team 1	Team 1 is 1st on scene Perform fire, rescue, and other duties. Perform fire, rescue, and other duties.		
Wrench Team 2	Team 2 is 2nd on scene Perform fire, rescue, and other duties. Perform fire, rescue, and other duties.		
Engine	Engine 42 is 3rd on scene Perform fire, rescue, and other duties. Perform fire, rescue, and other duties.		
Wrench Team 3	Team 3 is 4th on scene Perform fire, rescue, and other duties. Perform fire, rescue, and other duties.		
Wrench Team 4	Team 4 is 5th on scene Perform fire, rescue, and other duties. Perform fire, rescue, and other duties.		
Wrench Team 5	Team 5 is 6th on scene Perform fire, rescue, and other duties. Perform fire, rescue, and other duties.		
Engine 42	Engine 42 is 7th on scene Perform fire, rescue, and other duties. Perform fire, rescue, and other duties.		
Engine 43	Engine 43 is 8th on scene Perform fire, rescue, and other duties. Perform fire, rescue, and other duties.		
Engine 44	Engine 44 is 9th on scene Perform fire, rescue, and other duties. Perform fire, rescue, and other duties.		
Engine 45	Engine 45 is 10th on scene Perform fire, rescue, and other duties. Perform fire, rescue, and other duties.		

EXHIBIT T

DELETED

EXHIBIT U

DELETED

EXHIBIT V
DELETED

EXHIBIT W

DELETED

EXHIBIT X

DELETED

EXHIBIT Y

TRANSFEE ASSUMPTION AGREEMENT

THIS AGREEMENT is made as of this ____ day of _____, 201_, between the **CITY OF CHICAGO**, an Illinois home rule municipal corporation ("**City**"), **EC 42 DEVELOPER, LLC**, a Delaware limited liability company ("**Developer**"), and _____ ("**Transferee**").

WITNESETH:

WHEREAS, pursuant to that certain real estate sale contract dated _____, 20__ , the Transferee agreed to purchase from Developer its interest in certain real property situated in Cook County, Illinois and legally described in **Exhibit A** attached to and, by this reference, made a part of this Agreement ("**Property**"); and

WHEREAS, following the conveyance of the interest of Developer in the Property by Developer, the Transferee will have an interest in the Property; and

WHEREAS, as a condition to the conveyance of the interest in the Property by **Developer**, the City, and ____ require that the Transferee agree to comply with all the terms, requirements, and obligations set forth in that certain Redevelopment Agreement, dated as of _____, 2018, and recorded in the office of the Cook County Recorder on _____, 2018, as Document No. _____, by and between the City and the Developer ("**Development Agreement**");

NOW, THEREFORE, in consideration of the agreement of Developer to convey its interest in the Property to the Transferee, and of the City, and of Transferee to accept the transfer of obligations as provided herein and to grant the releases granted herein, and for other good and valuable consideration, the receipt and sufficiency of which are hereby acknowledged, it is hereby agreed by, between, and among the City, Developer, and the Transferee as follows:

1. **Recitals.** The foregoing recitals are by this reference incorporated herein and made a part hereof as substantive provisions of this Agreement.

2. **Assumption of Obligations.** The Transferee, on its behalf and on behalf of its successors, assigns, heirs, executors, and administrators, hereby agrees, at its sole cost and expense, to comply with all of the terms, requirements, and obligations of the Development Agreement, including all exhibits and attachments thereto, regardless of whether such terms, requirements, and obligations are to be performed and provided by, or are imposed upon, **[Developer/____]**.

3. **Payment of City Fees and Costs.** In addition to any other costs, payments, fees, charges, contributions, or dedications required by this Agreement, the Development Agreement or by applicable City codes, ordinances, resolutions, rules, or regulations, the Transferee shall pay to the City, immediately upon presentation of a written demand or demands therefor, all legal, engineering, and other consulting or administrative fees,

costs, and expenses incurred in connection with the negotiation, preparation, consideration, and review of this Agreement.

4. **Acknowledgment and Release of [Developer/_____] .** The City hereby acknowledges its agreement to the Transferee's assumption of the obligation to comply with the terms, requirements, and obligations of the Development Agreement, including all exhibits and attachments thereto, and the City hereby releases **[Developer/_____]** from any liability for failure to comply with the terms, requirements, and obligations of the Development Agreement.

IN WITNESS WHEREOF, the parties hereto have caused this Agreement to be executed as of the day and year first written above.

ATTEST:

CITY OF CHICAGO,
an Illinois home rule municipal corporation

By: _____
Its: _____

ATTEST:

EC 42 DEVELOPER, LLC,
a Delaware limited liability company

By:

By: _____

By: _____

Its: _____

Its: _____

[Other Transferors To Be Determined]

ATTEST:

[TRANSFEREE]

By: _____

By: _____

Its: _____

Its: _____

ACKNOWLEDGMENTS

STATE OF ILLINOIS)
)
COUNTY OF COOK) SS

This instrument was acknowledged before me on _____, 201_, by _____, the _____ of the **CITY OF CHICAGO**, an Illinois home rule municipal corporation, and by _____, the _____ of said municipal corporation.

Signature of Notary

SEAL

STATE OF ILLINOIS)
)
COUNTY OF ____) SS

This instrument was acknowledged before me on _____, 201_, by _____ the _____ of _____, a _____ limited liability company, and by _____, the _____ of said limited liability company.

Signature of Notary

SEAL

STATE OF _____)
) SS.
COUNTY OF _____)

This instrument was acknowledged before me on _____, 201_, by _____, the _____ of _____, an _____ limited liability company, and by _____, the _____ of said limited liability company.

Given under my hand and official seal this ___ day of _____, 201_.

Notary Public

My Commission expires: _____

SEAL

STATE OF ILLINOIS)
) SS
COUNTY OF _____)

This instrument was acknowledged before me on _____, 201_, by _____ the _____ of [TRANSFEREE], and by _____, the _____ of [TRANSFEREE].

Signature of Notary

EXHIBIT Z

WEST FIREHOUSE PORTION

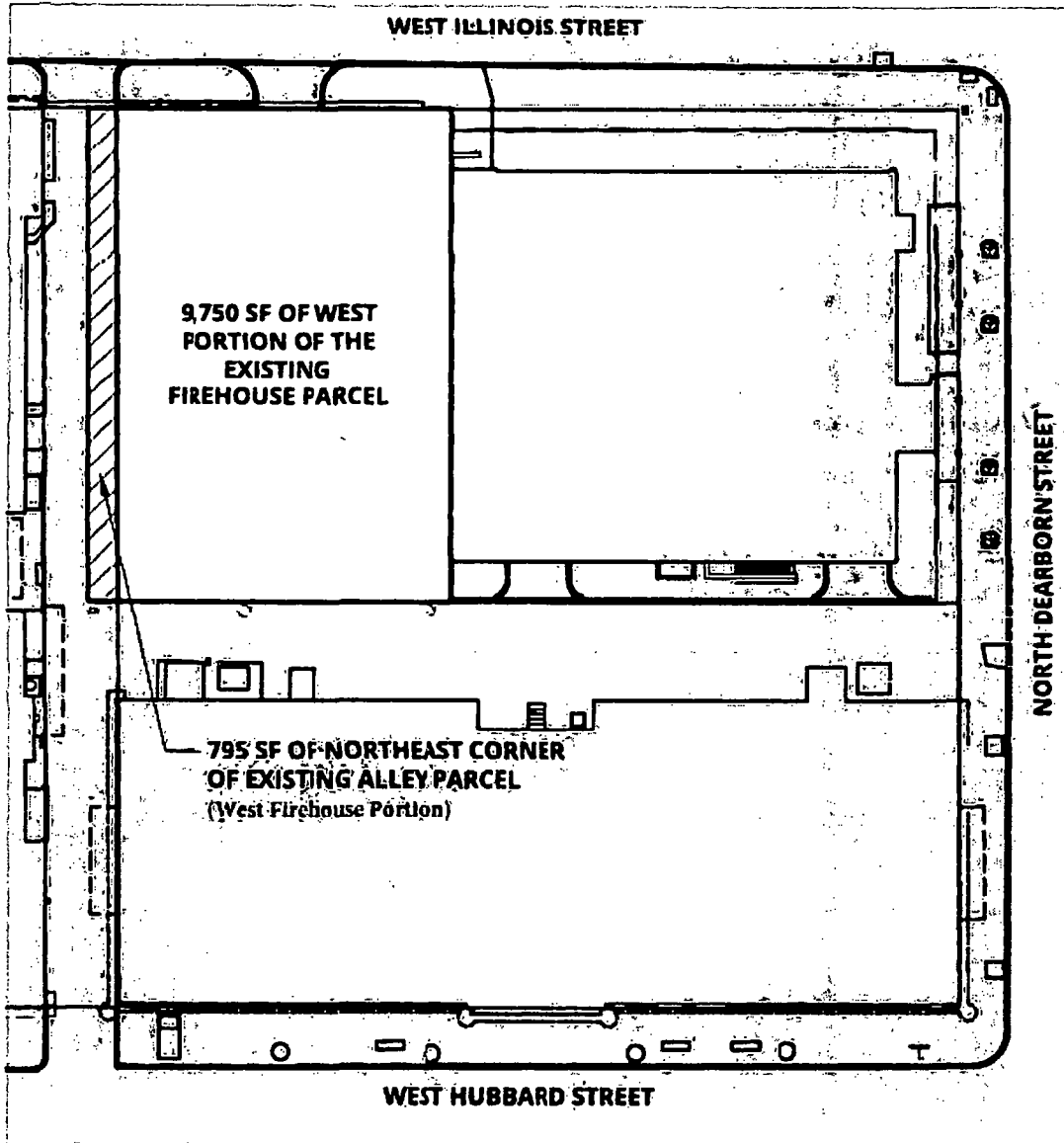

FIGURE 3.1.1 (2) 2/15/17 IS UNFINISHED

FRIEDMAN
PROPERTIES
312.644.1100 | friedmanproperties.com

55 W Illinois Street
New Firehouse Parcel

02/15/2017

EXHIBIT AA
HAZMAT SURVEY



557 West Polk Street, Suite 201
Chicago, IL 60644
312.447.1200 p
312.447.0922 f
www.egsl.com w

Hazardous Materials Survey Report

55 West Illinois Street, Chicago, Illinois 60654

EGSL Project #: 1707585

Report Date: October 23, 2017



Prepared for:	Prepared by:
Mr. Nick Helmer Jr.	Mary Cappellini
EC 42 Developer LLC	Asbestos Building Inspector
350 North Clark Street	(IDPH #100-18709)
Floor 4	Lead Risk Assessor
Chicago, Illinois 60654	(IDPH #014627)

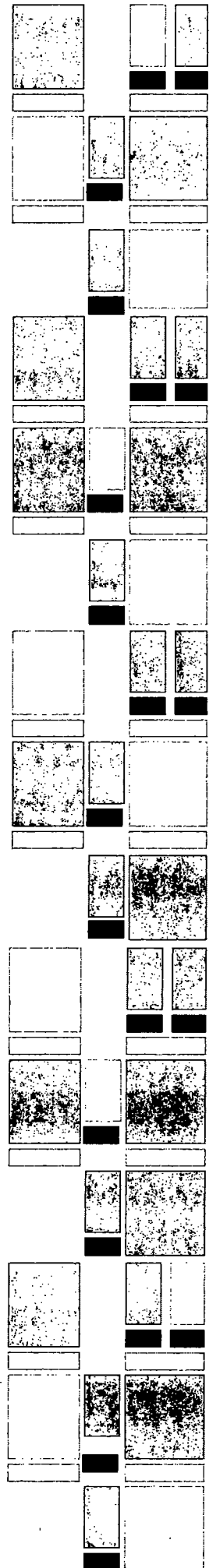

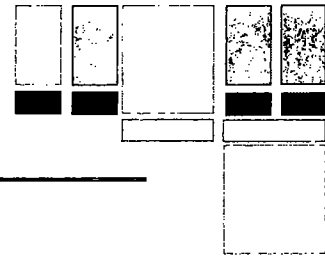

1. EXECUTIVE SUMMARY

On October 13, 2017, *Environmental Group Services Ltd.* (EGSL) personnel performed a hazardous material survey of the *Chicago Fire Department Station* located at 55 West Illinois Street, Chicago, Illinois. The building is comprised of a two-story building that is currently utilized as a fire house. The building is mostly slab-on-grade, with a small partial basement underneath the southeast portion of the building. The hazardous materials survey addressed asbestos containing materials and lead based paint. Furthermore, EGSL took note of other possible hazardous materials at the site such as fluorescent light ballasts that may contain PCBs, transformers at the property, thermostats, and other hazardous chemicals housed on-site. The inspection was conducted due to the proposed demolition of the building. Only visible and accessible materials were sampled and observed.

Asbestos Survey

EGSL sampled various building materials at the property in order to determine whether asbestos content was present. Of the sampled materials, asbestos fibers were detected within the 9x9 floor tile/mastic outside of the 1st floor racquetball court and 9x9 floor tile/mastic throughout the 2nd floor at concentrations above the regulatory level of 1%. Therefore, these materials are considered asbestos containing materials.

Lead Based Paint Survey

EGSL obtained ten (10) XRF readings within the building. None of the investigated surfaces contained lead paint above the regulatory level of 1.0 mg/cm².

Other Hazardous Materials Comments

- ✓ Multiple fluorescent lights were observed within the building.
- ✓ There are no elevators present within the building.
- ✓ EGSL did not observe any thermostats that could potentially contain mercury within the building.
- ✓ EGSL did not observe any transformers at the property.

2. ASBESTOS SURVEY

2.1 Asbestos Sampling

The inspection was in keeping with federal regulations which state, "the owner or operator of a demolition or renovation activity and prior to the commencement of the demolition or renovation will thoroughly inspect the affected facility or part of the facility where the demolition or renovation operation will occur for the presence of asbestos" (*National Emission Standards for Hazardous Air Pollutants* (NESHAP): Asbestos [40 Code of Federal Regulations (CFR) Part 61, Subpart M])* and the City of Chicago regulations (Asbestos, Demolition or Renovation, Sandblasting, and Grinding Standards-City Code 11-4-2150 - 11-4-2190) must also be adhered to.

Bulk material samples of a presumed asbestos containing building material (PACBM) were collected by Mary Cappellini of EGSL, an EPA accredited and licensed *Illinois Department of Public Health* (IDPH) Asbestos Building Inspector (IDPH license #100-18709). Only visible and accessible materials were sampled. EGSL personnel conducted a visual inspection to identify possible homogeneous areas of the



presumed asbestos-containing building materials (PACBM). Building material bulk samples of the PACBM were collected for laboratory analysis prior to the planned demolition or renovation.

Asbestos bulk samples were obtained following EPA and OSHA protocols. Thirty-three (33) asbestos bulk samples were collected and submitted to *STAT Analysis Corporation* in Chicago, Illinois, for Asbestos Analysis by Polarized Light Microscopy (PLM) Asbestos Analysis of Bulk Materials via method: EPA-600/M4-82-020. The proper chain of custody was implemented from sample collection through analysis.

2.2 Asbestos Analytical Results

The following table itemizes each sampled material, their location, and if asbestos fibers were detected. Any building material containing asbestos fibers greater than 1% is highlighted in yellow, and considered an asbestos containing material by local, state, and federal regulations (refer to Attachment B for the analytical results).

Material Description	Location	Friable ¹	NESHAP Category ²	Sample #/S	Asbestos Content
9x9 Gray Floor Tile with White Specs	Outside 1 st Floor Racquetball Court	N	Cat I Non Friable	1 2 3	Chrysotile Asbestos 1-5% Chrysotile Asbestos 1-5% Chrysotile Asbestos 1-5%
9x9 Gray Floor Tile with White Specs Mastic	Outside 1 st Floor Racquetball Court	N	Cat I Non Friable	1M 2M 3M	Chrysotile Asbestos 1-5% Chrysotile Asbestos 1-5% Chrysotile Asbestos 1-5%
12x12 Tan Floor Tile with White Specs	1 st Floor Kitchen	N	N/A	4 5 6	None Detected None Detected None Detected
12x12 Tan Floor Tile with White Specs Mastic	1 st Floor Kitchen	N	N/A	4M 5M 6M	None Detected None Detected None Detected
9x9 Gray Floor Tile with White Specs	Throughout 2 nd Floor (locker rooms/bunk rooms)	N	Cat I Non Friable	7 8 9	Chrysotile Asbestos 1-5% Chrysotile Asbestos 1-5% Chrysotile Asbestos 1-5%
9x9 Gray Floor Tile with White Specs Mastic	Throughout 2 nd Floor (locker rooms/bunk rooms)	N	Cat I Non Friable	7M 8M 9M	Chrysotile Asbestos 1-5% Chrysotile Asbestos 1-5% Chrysotile Asbestos 1-5%
Ceiling Tile	Kitchen and 2 nd Floor	N	N/A	10 11 12	None Detected None Detected None Detected
12x12 Beige Floor Tile with White Specs	2 nd Floor Offices	N	N/A	13 14 15	None Detected None Detected None Detected
12x12 Beige Floor Tile with White Specs Mastic	2 nd Floor Offices	N	N/A	13M 14M 15M	None Detected None Detected None Detected

Plaster	1 st Floor Racquetball Court/Bathrooms/ 2 nd Floor	N	N/A	16 Skim 17 Skim 18 Skim	None Detected None Detected None Detected
Plaster	1 st Floor Racquetball Court/Bathrooms/ 2 nd Floor	N	N/A	16 Base 17 Base 18 Base	None Detected None Detected None Detected

¹Yes (Y) or No (N) ²Friable ACM or Category 1 NonFriable ACM (Cat. I NF ACM) or Category II Nonfriable ACM (Cat. II NF ACM)

3. LEAD BASED PAINT SURVEY

3.1 Lead Based Paint Sampling

EGSL utilized an RMD LPA-1 XRF (X-Ray Fluorescence) Analyzer to determine whether select painted surfaces exceeded the Housing and Urban Development guidelines for lead based paint concentrations of 1.0 mg/cm² (1997 Revision-Chapter 7 of the 1995-HUD Guidelines for the Evaluation and Control of Lead-Based Paint Hazards in Housing). Portable XRF lead-based paint analyzers are the most common primary analytical method for inspections in housing because of their demonstrated abilities to determine if lead-based paint is present on many surfaces and to measure the paint without destructive sampling or paint removal. Portable XRF instruments expose a building component to X-rays or gamma radiation, which causes lead to emit X-rays with a characteristic frequency or energy. The intensity of this radiation is measured by the instrument. The LPA-1 XRF Analyzer measures lead in paint with a 95% confidence level.

3.2 XRF Calibration Check

The calibration of the XRF instrument was performed using the paint film nearest 1.0 mg/cm² in the *National Institute of Standards and Technology* (NIST) Standard Reference Material (SRM), therefore a calibration block, which has a standard paint film value of 1.0 mg/cm² was used. Three calibration checks were performed before and after the lead based survey and all registered values were within the acceptable NIST limits of 1.0 ± 0.3 (0.7 to 1.3) mg/cm².

3.3 XRF Analytical Results

The following table depicts the shot number, location, color of the paint film, and lead concentration within the paint. None of the investigated surfaces were found to contain lead content above the regulatory level of mg/cm². Refer to Attachment C for the XRF readings.

Shot #	Location	Color	Lead Concentration
1	Basement Boiler Room (East Wall)	Green/Gray	-0.5
2	Basement Boiler Room (South Wall)	Green/Gray	-0.4
3	Basement Locker Room (West Wall)	White	-0.3
4	Northwest Basement/1 st Floor Stairwell Glazed Brick	Glazing	-0.6
5	Stairwell Railing	Black	-1.0

6	Stairwell Railing	Black	-0.3
7	Racquetball Court (East Wall)	Cream	-0.5
8	Racquetball Court (West Wall)	Cream	-0.3
9	Racquetball Court Bathroom (West Wall)	Cream	-0.2
10	1 st Floor Garage Glazed Block Walls	Glazing	-0.7

4. Other Hazardous Materials

Other than the above mentioned hazardous concerns (asbestos, lead paint), EGSL conducted a visual inspection of the property in order to determine whether additional hazardous materials could be located on-site. The following comments are as follows:

- ✓ Multiple fluorescent lights were observed within the building.
- ✓ There are no elevators present within the building.
- ✓ EGSL did not observe any thermostats that could potentially contain mercury within the building.
- ✓ EGSL did not observe any transformers at the property.

5. RECOMMENDATIONS

EGSL conducted a hazardous materials survey within the *Chicago Fire Department Station* located at 55 West Illinois Street, Chicago, Illinois. According to the analytical results, multiple hazardous materials were identified. The following details the recommendation for each of the hazardous materials identified.

Asbestos

All highlighted asbestos containing materials identified in Section 2.2 of this report should be removed by a licensed asbestos contractor in accordance with all local, state, and federal regulations, prior to any disturbance, renovation, or demolition activities.

Lead Based Paint

No lead based paint was identified during the site inspection; therefore, there are no further recommendations regarding lead based paint at the Subject Property.

Other Hazardous Materials

All fluorescent light ballasts should be disposed of properly in accordance with all local, state, and federal regulations.



Mary Cappellini (Project Manager)
IDPH ABI License (100-18709)
IDPH LBP License (014627)



Report Reviewer

Shadow Mirkhaef (President)
IDPH License (100-00057)

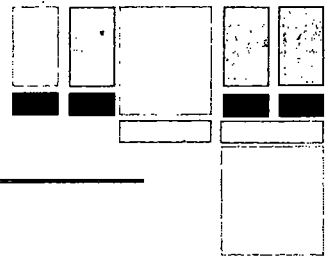

ATTACHMENT A – Photographic Documentation

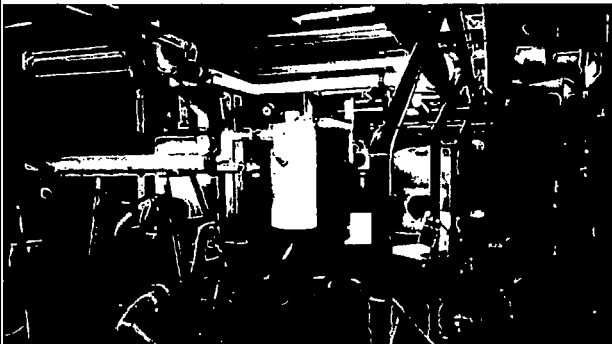
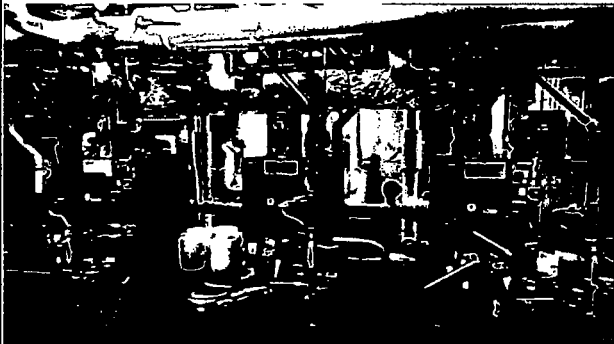
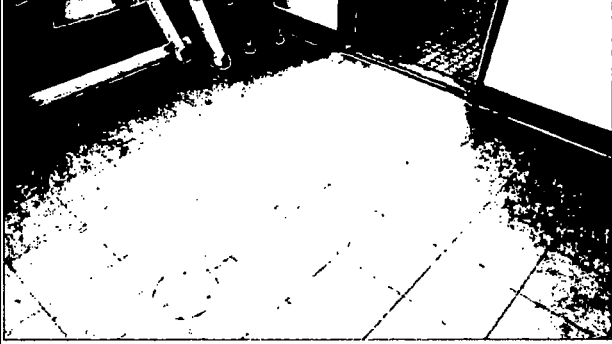
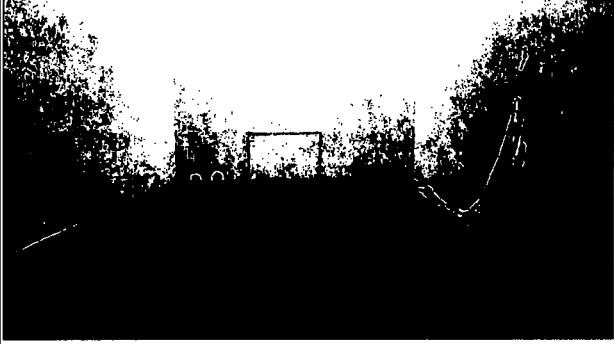
	
General Basement Boiler Room View	General Basement Boiler Room View
	
Fluorescent Light Ballasts Basement	Glazed Brick within Stairwell
	
9x9 Floor Tile Outside of Racquetball Court (Positive for Asbestos Fibers Greater than 1%)	View of Racquetball Court

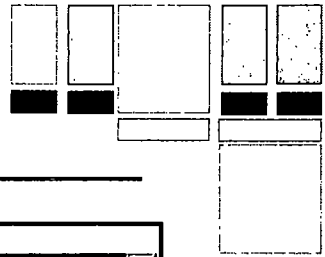

<p>Glazed Brick within Garage</p>	<p>12x12 Floor Tile 1st Floor Kitchen</p>
<p>9x9 Floor Tile 2nd Floor (Positive for Asbestos Fibers Greater than 1%)</p>	<p>12x12 Floor Tile 2nd Floor Offices</p>
<p>Ceiling Tile 2nd Floor</p>	

EGSL Project No. 1707585: 55 West Illinois Street, Chicago, Illinois 60654

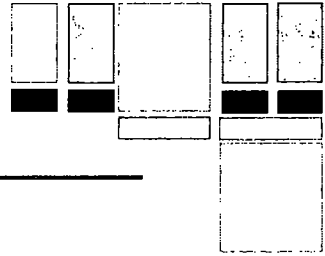

ATTACHMENT B – PLM Analytical Results

ASBESTOS ANALYSIS BY POLARIZED LIGHT MICROSCOPY

Method: EPA/600/R-93/116

Environmental Group Services, Ltd.

557 W. Polk Suite 201

Chicago, IL 60610

Phone: (312) 447-1200

Fax: (312) 447-0922

Reference:

Location: Illinois, Chicago

Batch No.: 332849

Customer No.: 177

Date Received: 10/16/2017

Date Analyzed: 10/17/2017

Date Reported: 10/17/2017

Turn Around Time: 24 Hour

Laboratory Sample	Customer Sample Number	Color	Asbestos Components (%)	Non-Asbestos Components (%)
332849001	1	TN	Chrysotile 1-5%	Binder 95-99%
332849002	2	TN	Chrysotile 1-5%	Binder 95-99%
332849003	3	TN	Chrysotile 1-5%	Binder 95-99%
332849004	1M	BK	Chrysotile 1-5%	Binder 95-99%
332849005	2M	BK	Chrysotile 1-5%	Binder 95-99%
332849006	3M	BK	Chrysotile 1-5%	Binder 95-99%
332849007	4	GY	ND	Binder 99-100%
332849008	5	GY	ND	Binder 99-100%
332849009	6	GY	ND	Binder 99-100%
332849010	4M	YL/BK	ND	Binder 99-100%
332849011	5M	YL/BK	ND	Binder 99-100%
332849012	6M	YL/BK	ND	Binder 99-100%
332849013	7	GY	Chrysotile 5-10%	Binder 90-95%
332849014	8	GY	Chrysotile 5-10%	Binder 90-95%
332849015	9	GY	Chrysotile 5-10%	Binder 90-95%
332849016	7M	BK	Chrysotile 1-5%	Binder 95-99%
332849017	8M	BK	Chrysotile 1-5%	Binder 95-99%
332849018	9M	BK	Chrysotile 1-5%	Binder 95-99%

ND = Asbestos Not Detected (Not Present)

NA = Not Analyzed

NS = Not Submitted

Color Codes: YL = Yellow RD = Red PL = Purple WH = White BN = Brown TN = Tan/Beige

OR = Orange BL = Blue GR = Green BK = Black GY = Grey PK = Pink

Components of inhomogeneous samples are analyzed per our Standard Operating Procedure, or per customer request.

The use of the NVLAP logo does not imply endorsement by NVLAP or any agency of the US Government.

The information contained in this report and any attachments is confidential information intended only for the use of the individual or entities named above. The results of this report relate only to the samples tested. If you have received this report in error, please notify us immediately by phone. This report shall not be reproduced, except in its entirety, unless written approval has been obtained from the laboratory. This report remains property of STAT Analysis until payment is received in full (see invoice)

Analyzed by Name :

Henry Robateau / Microscopist

Date: 10/17/2017

ASBESTOS ANALYSIS BY POLARIZED LIGHT MICROSCOPY

Method: EPA/600/R-93/116

Environmental Group Services, Ltd.

557 W. Polk Suite 201

Chicago, IL 60610

Phone: (312) 447-1200

Fax: (312) 447-0922

Reference:

Location: Illinois, Chicago

Batch No.: 332849

Customer No.: 177

Date Received: 10/16/2017

Date Analyzed: 10/17/2017

Date Reported: 10/17/2017

Turn Around Time: 24 Hour

Laboratory Sample	Customer Sample Number	Color	Asbestos Components (%)	Non-Asbestos Components (%)
332849019	10	GY/WH	ND	Cellulose 30-35% Binder 30-35% Glass 30-35%
332849020	11	GY/WH	ND	Cellulose 30-35% Binder 30-35% Glass 30-35%
332849021	12	GY/WH	ND	Cellulose 30-35% Binder 30-35% Glass 30-35%
332849022	13	TN	ND	Binder 99-100%
332849023	14	TN	ND	Binder 99-100%
332849024	15	TN	ND	Binder 99-100%
332849025	13M	YL	ND	Binder 99-100%
332849026	14M	YL	ND	Binder 99-100%
332849027	15M	YL	ND	Binder 99-100%
332849028	16 Skim	WH	ND	Binder 99-100%
332849029	17 Skim	WH	ND	Binder 99-100%
332849030	18 Skim	WH	ND	Binder 99-100%
332849031	16 Base	WH	ND	Binder 90-95% Other 5-10%

ND = Asbestos Not Detected (Not Present)

NA = Not Analyzed

NS = Not Submitted

Color Codes: YL = Yellow RD = Red PL = Purple WH = White BN = Brown TN = Tan/Beige

OR = Orange BL = Blue GR = Green BK = Black GY = Grey PK = Pink

Components of inhomogeneous samples are analyzed per our Standard Operating Procedure, or per customer request

The use of the NVLAP logo does not imply endorsement by NVLAP or any agency of the US Government

The information contained in this report and any attachments is confidential information intended only for the use of the individual or entities named above. The results of this report relate only to the samples tested. If you have received this report in error, please notify us immediately by phone. This report shall not be reproduced, except in its entirety, unless written approval has been obtained from the laboratory. This report remains property of STAT Analysis until payment is received in full (see invoice).

Analyzed by Name :

Henry Robateau / Microscopist



NVLAP Lab Code 101202-0

ASBESTOS ANALYSIS BY POLARIZED LIGHT MICROSCOPY

Method: EPA/600/R-93/116

Environmental Group Services, Ltd.
 557 W. Polk Suite 201
 Chicago, IL 60610
 Phone: (312) 447-1200
 Fax: (312) 447-0922

Reference:		Date Received: 10/16/2017
Location:	Illinois, Chicago	Date Analyzed: 10/17/2017
Batch No.:	332849	Date Reported: 10/17/2017
Customer No.:	177	Turn Around Time: 24 Hour

Laboratory Sample	Customer Sample Number	Color	Asbestos Components (%)	Non-Asbestos Components (%)
332849032	17 Base	WH	ND	Binder 90-95% Other 5-10%
332849033	18 Base	WH	ND	Binder 90-95% Other 5-10%

ND = Asbestos Not Detected (Not Present) NA = Not Analyzed NS = Not Submitted
 Color Codes: YL = Yellow RD = Red PL = Purple WH = White BN = Brown TN = Tan/Beige
 OR = Orange BL = Blue GR = Green BK = Black GY = Grey PK = Pink

Components of inhomogeneous samples are analyzed per our Standard Operating Procedure, or per customer request.

The use of the NVLAP logo does not imply endorsement by NVLAP or any agency of the US Government.

The information contained in this report and any attachments is confidential information intended only for the use of the individual or entities named above. The results of this report relate only to the samples tested. If you have received this report in error, please notify us immediately by phone. This report shall not be reproduced, except in its entirety, unless written approval has been obtained from the laboratory. This report remains property of STAT Analysis until payment is received in full (see invoice).

Analyzed by Name :

Henry Robitseau / Microscopist

Date: 10/17/2017



Analysis Corporation

2242 W. Harrison, Suite 200, Chicago, Illinois 60612 Phone: (312) 733-0551 Fax: (312) 733-2386
e-mail address: STATIn@a@STATAnalysis.com AIHA accredited 101160 NYLAP lab code 101202-0

CHAIN OF CUSTODY RECORD

Page: 1 of 1

Client: EGSL

Street Address: 557 W. Polk St - Suite 201

City, State, Zip: Chicago IL 60607

Phone: 312-447-1200

Fax: 312-447-0922

e-mail/Alt. Fax: MARY@EGSL.COM

Project Number: Illinois

Project Name: Chicago

Project Location: MARY Cappellini

P. O. Number: _____

Turn Around: Immediate 4 Hrs 8 Hrs 24 Hrs 1 Day 2 Days 3 Days 5 Days

Date Due _____ Time Due _____

OFFICE USE ONLY BELOW:

Batch No.: 332849

Samples Acceptable Yes No

Checked by (Initial/Date): MA 10/17/17

QC by (Initial/Date): _____

Reported By (Initial/Date/Time/Method): _____

Comments: _____

Note: Not all turn around times are available for all analysis

Reinquinished by: MARY Cappellini Date/Time: 10/16/17 8:30

Received by: MARY Cappellini Date/Time: 10/17/17 10:15

Reinquinished by: MARY Cappellini Date/Time: 10/16/17 16:19

Received by: MARY Cappellini Date/Time: 10/17/17 10:19

Reinquinished by: _____ Date/Time: _____

Received by: _____ Date/Time: _____

Client Sample Number/Description	Date Taken	Time		Rate (ppm)	Volume (Liters)	Area Wiped (ft ²)	Laboratory Sample No.	Analysis									
		On	Off					PCM Asbestos	PLM Asbestos (Bulk)	PLM Point Count	PLM Gravimetric	TEM Air Asbestos	TEM Bulk Asbestos	TEM Gravimetric Asb	TEM Microvac Ash	FEM Water	Other
11/2/3 - 7x9 FT (TAN w/white) - OUTSIDE ESO. BELT CT.	10/13/17							X									
4/5/6 - 12x12 FT (TAN w/white) - 1st Fl. KITCHEN								X									
7/8/9 - 6x9 (TAN w/white) - 2nd Fl. COFFEE RM								X									
10/11/12 - ceiling tile (KITCHEN + 2nd Fl.)								X									
13/14/15 - 12x12 FT (TAN w/white) - 2nd Fl. OFFICE								X									
16/17/18 - PLASTER								X									

Comments: _____

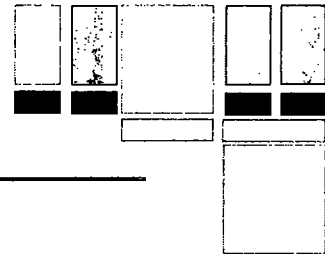

ATTACHMENT C – XRF Readings

"Job Start", "10/13/17", "15:55:00", "Job
Stop", "10/13/17", "16:19:00", "Abatement Level", 1.0, "Serial Number", 03522

0001, -0.5, "", " QM"
0002, -0.4, "", " QM"
0003, -0.3, "", " QM"
0004, -0.6, "", " QM"
0005, -1.0, "", " QM"
0006, -0.3, "", " QM"
0007, -0.5, "", " QM"
0008, -0.3, "", " QM"
0009, -0.2, "", " QM"
0010, -0.7, "", " QM"

EXHIBIT BB

DELETED

EXHIBIT CC

DELETED

EXHIBIT DD

PHASE I LOGISTICS PLAN



441 N. DEARBORN ST.
 EC-42
 PROJECT: 11028763
 LOG: 005-1

DATE: 08/14/2018
 DRAWN BY: JAH
 CHECKED BY: JAH
 PROJECT: 11028763
 LOG: 005-1

1. This drawing is the property of the engineering firm and shall not be reproduced, copied, or used in any manner without the written consent of the engineering firm.
 2. The engineer and architect are not responsible for the construction of the project or for any damage to property or persons resulting from the use of this drawing.
 3. The engineer and architect are not responsible for the accuracy of the information provided by the client or other sources.
 4. The engineer and architect are not responsible for the construction of the project or for any damage to property or persons resulting from the use of this drawing.
 5. The engineer and architect are not responsible for the accuracy of the information provided by the client or other sources.

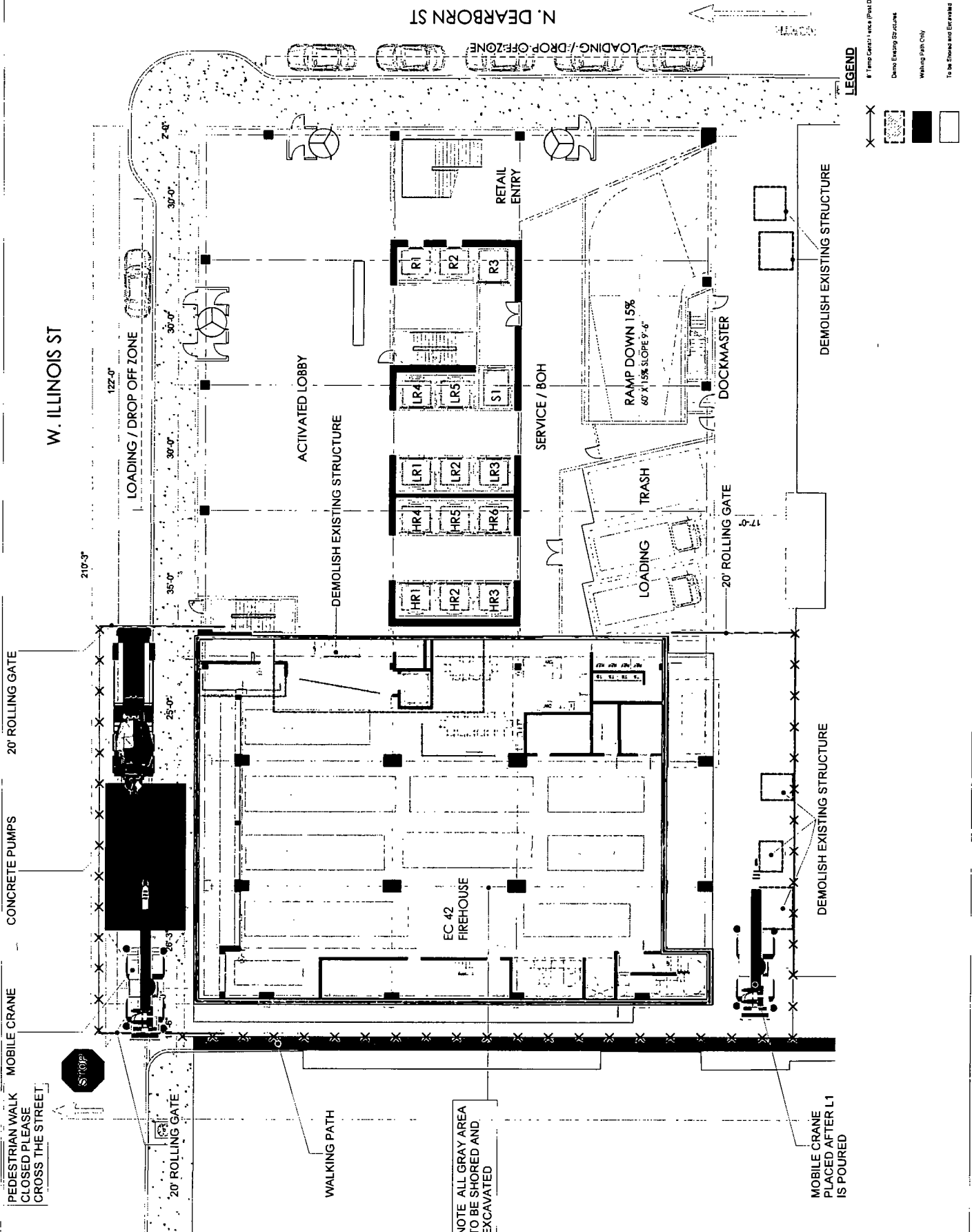

LEGEND

- Temp Center (see Plan Sheet)
- Demolish Existing Structure
- Walking Path Only
- To Be Demolish and Excavate

NOTE ALL GRAY AREA TO BE SHORED AND EXCAVATED

MOBILE CRANE PLACED AFTER L1 IS POURED

PEDESTRIAN WALK CLOSED PLEASE CROSS THE STREET

EXHIBIT EE

PERFORMANCE BOND AND LABOR AND MATERIALS BOND

CITY OF CHICAGO

DEARBORN FIREHOUSE REDEVELOPMENT AGREEMENT

KNOW ALL MEN BY THESE PRESENTS: that **[EC 42 DEVELOPER LLC**, as Principal, ("**Developer**"), and **[FULL NAME AND ADDRESS OF SURETY]**, as Surety, a corporation organized and existing under the laws of the State of **[INCORPORATION]**, ("**Surety**"), are held and firmly bound unto the City of Chicago, 121 N. LaSalle Street, Chicago, Illinois, 60602, as Obligee, ("**Owner**"), in the full and just sum of **[TBD]** Dollars (**[\$TBD]**), for the payment of which sum of money well and truly to be made, Developer and Surety bind themselves, their heirs, executors, administrators, successors and assigns, jointly and severally, firmly by these presents, said amount to include payment of actual costs and damages and for attorneys' fees, architectural fees, design fees, engineering fees, accounting fees, testing fees, consulting fees, administrative costs, court costs, interest and any other fees and expenses resulting from or incurred by reason of Developer's failure to promptly and faithfully perform its Agreement with Owner, said Agreement being more fully described below, and to include attorneys' fees, court costs and administrative and other expenses necessarily paid or incurred in successfully enforcing performance of the obligation of Surety under this bond.

WHEREAS, Developer has entered into a written agreement dated **[DATE OF AGREEMENT]**, with Owner entitled **DEARBORN FIREHOUSE REDEVELOPMENT AGREEMENT** ("**Agreement**"), the terms and conditions of which are by this reference incorporated herein as though fully set forth herein.

NOW, THEREFORE, THE CONDITION OF THIS OBLIGATION IS SUCH THAT if Developer shall well, truly and promptly perform all the undertakings, covenants, terms, conditions and agreements of said Developer under the Agreement, including, but not limited to, Developer's obligations under the Agreement: (1) to provide, perform and complete the Firehouse Work in the manner specified in the Agreement, including all necessary work, labor, services, transportation, equipment, materials, apparatus, machinery, tools, fuels, gas, electric, water, waste disposal, information, data and other means and items necessary for the Firehouse Work; (2) to procure and furnish all permits, licenses and other governmental approvals and authorizations necessary in connection therewith; (3) to procure and furnish all bonds, certificates and policies of insurance specified in the Agreement; (4) to pay all applicable federal, state and local taxes; (5) to do all other things required of Developer by the Agreement; and (6) to provide, perform and complete all of the foregoing in a proper and workmanlike manner and in full compliance with, and as required by and pursuant to, the Agreement; ("**Work**,") whether or not any of said Work enter into and become component parts of the

improvement contemplated, then this obligation shall be null and void; otherwise it shall remain in full force and effect.

Surety, for value received, hereby stipulates and agrees that no changes, modifications, alterations, omissions, deletions, additions, extensions of time, or forbearances on the part of either Owner or Developer to the other in or to the terms of said Agreement; in or to the schedules, plans, drawings or specifications; in or to the method or manner of performance of the Work; in or to Owner-furnished facilities, equipment, material, service or sites; or in or to the mode or manner of payment therefor, shall in any way release Developer and Surety or either or any of them, or any of their heirs, executors, administrators, successors or assigns or affect the obligations of Surety on this bond, all notice of any and all of the foregoing changes, modifications, alterations, omissions, deletions, additions, extensions of time or forbearances, and notice of any and all defaults by Developer or of Owner's termination of Developer being hereby waived by Surety.

Notwithstanding anything to the contrary in the foregoing paragraph, in no event shall the obligations of Surety under this bond in the event of Developer's default be greater than the obligations of Developer under the Agreement in the absence of such Developer default.

In the event of a default or defaults by Developer, Owner shall have the right to take over and complete the Agreement upon 30 calendar days' written notice to Surety, in which event Surety shall pay Owner all costs incurred by Owner in taking over and completing the Agreement.

At its option, Owner may instead request that Surety take over and complete the Agreement, in which event Surety shall take reasonable steps to proceed promptly with completion no later than 30 calendar days from the date on which Owner notifies Surety that Owner wants Surety to take over and complete the Agreement.

Owner shall have no obligation to actually incur any expense or correct any deficient performance of Developer in order to be entitled to receive the proceeds of this bond.

No right of action shall accrue on this bond to or for the use of any person or corporation other than Owner or the heirs, executors, administrators or successors of Owner.

Signed and sealed this ____ day of _____, 2018.

Attest/Witness:

PRINCIPAL: *EC 42 DEVELOPER LLC*

By: _____

By: _____

*[NAME OF DEVELOPER'S
EXECUTING OFFICER]*

Title: _____

Title: *[TITLE OF DEVELOPER'S
EXECUTING OFFICER]*

Attest/Witness:

SURETY: *NAME OF SURETY*

By: _____

By: _____

Title: _____

Title: _____

Telephone: _____

EXHIBIT FF

MASSING AND BULK TABLE FOR NEW DEVELOPMENT

BULK REGULATIONS AND DATA TABLE

	Control	Control D	Control D	Control D	Control D
Net Site Area (Acres)	21,453 ac	11,000 ac	47,271 ac	23,120 ac	11,520 ac
Open Space (Acres)	4,720 ac	1,100 ac	22,210 ac	11,000 ac	11,520 ac
Area of Impervious Surface (Acres)	17,733 ac	0	25,061 ac	12,120 ac	0 ac
Impervious Surface					100% 0%
Impervious Surface					48 25,061 ac
Maximum Development Potential (Acres)	11,000 ac	11,000 ac	11,000 ac	11,000 ac	11,000 ac
Maximum Potential (Acres)	11,000 ac	11,000 ac	11,000 ac	11,000 ac	11,000 ac
Maximum Potential (Acres)	0	0	0	0	0
Maximum Potential (Acres)	0	0	21,151 ac	0	0
Maximum Potential (Acres)					

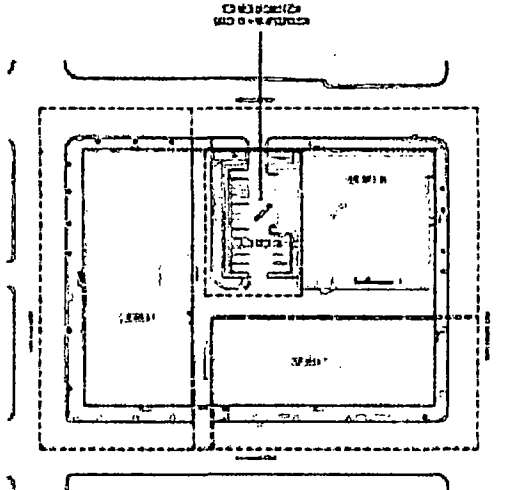

Sub Area Diagram

EXHIBIT GG

PHASE II LOGISTICS PLAN

PEDESTRIAN WALK
CLOSED PLEASE
CROSS THE STREET



HIGH DRIVE

TOWER CRANE

DUMPSTER

W. ILLINOIS ST

CANNOT BE OBSTRUCTED

24' ROLLING GATE

EXTENDED CANOPY

TRAILERS ABOVE
CANOPY

LOADING
DOCK

TEMP SKIP HOISTS

GROUND FLOOR
PLYWOOD OR
GYPSBOARD
ENCLOSURE

DUMPSTERS

20' ROLLING GATE

HIGH DRIVE

DOCK

OUTLINE OF BASEMENT WALL
BELOW

NORTH

CONCRETE PUMPS



ACTIVATED LOBBY

EC 42
FIREHOUSE

SERVICE / BOH

PAMP DOWN 15%

DOCKMASTER

DOCK

LEGEND

- X Temp. Control Panel (Plan, Elevation)
- ▬ Loading Dock
- ▬ Ground Floor / Precast or Opposed Enclosure



44410 BSA/BSRN/7
BSA/BSRN/7

NOTES:
1. All dimensions are in feet and inches, unless otherwise specified.
2. All dimensions are to the centerline of walls, unless otherwise specified.
3. All dimensions are to the finished floor, unless otherwise specified.
4. All dimensions are to the exterior face of walls, unless otherwise specified.
5. All dimensions are to the exterior face of slabs, unless otherwise specified.
6. All dimensions are to the exterior face of columns, unless otherwise specified.
7. All dimensions are to the exterior face of beams, unless otherwise specified.
8. All dimensions are to the exterior face of stairs, unless otherwise specified.
9. All dimensions are to the exterior face of ramps, unless otherwise specified.
10. All dimensions are to the exterior face of balconies, unless otherwise specified.
11. All dimensions are to the exterior face of terraces, unless otherwise specified.
12. All dimensions are to the exterior face of decks, unless otherwise specified.
13. All dimensions are to the exterior face of patios, unless otherwise specified.
14. All dimensions are to the exterior face of walkways, unless otherwise specified.
15. All dimensions are to the exterior face of driveways, unless otherwise specified.
16. All dimensions are to the exterior face of parking areas, unless otherwise specified.
17. All dimensions are to the exterior face of loading docks, unless otherwise specified.
18. All dimensions are to the exterior face of loading bays, unless otherwise specified.
19. All dimensions are to the exterior face of loading platforms, unless otherwise specified.
20. All dimensions are to the exterior face of loading bridges, unless otherwise specified.
21. All dimensions are to the exterior face of loading cranes, unless otherwise specified.
22. All dimensions are to the exterior face of loading hoists, unless otherwise specified.
23. All dimensions are to the exterior face of loading winches, unless otherwise specified.
24. All dimensions are to the exterior face of loading pulleys, unless otherwise specified.
25. All dimensions are to the exterior face of loading cables, unless otherwise specified.
26. All dimensions are to the exterior face of loading chains, unless otherwise specified.
27. All dimensions are to the exterior face of loading hooks, unless otherwise specified.
28. All dimensions are to the exterior face of loading latches, unless otherwise specified.
29. All dimensions are to the exterior face of loading pins, unless otherwise specified.
30. All dimensions are to the exterior face of loading bolts, unless otherwise specified.
31. All dimensions are to the exterior face of loading nuts, unless otherwise specified.
32. All dimensions are to the exterior face of loading washers, unless otherwise specified.
33. All dimensions are to the exterior face of loading spacers, unless otherwise specified.
34. All dimensions are to the exterior face of loading sleeves, unless otherwise specified.
35. All dimensions are to the exterior face of loading collars, unless otherwise specified.
36. All dimensions are to the exterior face of loading cones, unless otherwise specified.
37. All dimensions are to the exterior face of loading chocks, unless otherwise specified.
38. All dimensions are to the exterior face of loading dunnage, unless otherwise specified.
39. All dimensions are to the exterior face of loading blocks, unless otherwise specified.
40. All dimensions are to the exterior face of loading pads, unless otherwise specified.
41. All dimensions are to the exterior face of loading mats, unless otherwise specified.
42. All dimensions are to the exterior face of loading blankets, unless otherwise specified.
43. All dimensions are to the exterior face of loading covers, unless otherwise specified.
44. All dimensions are to the exterior face of loading tarps, unless otherwise specified.
45. All dimensions are to the exterior face of loading sheets, unless otherwise specified.
46. All dimensions are to the exterior face of loading fabrics, unless otherwise specified.
47. All dimensions are to the exterior face of loading papers, unless otherwise specified.
48. All dimensions are to the exterior face of loading plastics, unless otherwise specified.
49. All dimensions are to the exterior face of loading rubbers, unless otherwise specified.
50. All dimensions are to the exterior face of loading woods, unless otherwise specified.

44410 BSA/BSRN/7
BSA/BSRN/7

44410 BSA/BSRN/7
BSA/BSRN/7

44410 BSA/BSRN/7
BSA/BSRN/7

44410 BSA/BSRN/7
BSA/BSRN/7

44410 BSA/BSRN/7
BSA/BSRN/7

44410 BSA/BSRN/7
BSA/BSRN/7

44410 BSA/BSRN/7
BSA/BSRN/7

44410 BSA/BSRN/7
BSA/BSRN/7

44410 BSA/BSRN/7
BSA/BSRN/7

44410 BSA/BSRN/7
BSA/BSRN/7

EXHIBIT HH

PERFORMANCE SECURITY LETTER OF CREDIT

IRREVOCABLE LETTER OF CREDIT NO. _____ AMOUNT: _____

EXPIRATION DATE: _____ DATE OF ISSUE: _____

[Name of Bank]

[Address]

TO: City of Chicago
121 N. LaSalle Street
Chicago, Illinois 60602
Attention: _____

WE HEREBY AUTHORIZE YOU TO DRAW AT SIGHT on this Irrevocable Standby Letter of Credit No. _____ UP TO AN AGGREGATE AMOUNT OF _____ United States Dollars (\$ _____) for account of **EC 42 DEVELOPER LLC** (the "**Customer**").

Drafts under this Letter of Credit shall bear upon their face the words:

"Drawn under _____
Credit No. _____ Dated: _____"

Drafts may be for all or any portion of the amount of this Letter of Credit, and shall be in the form attached hereto as Exhibit "A" and shall be accompanied by one of the following documents executed by the City's Commissioner of the Department of Planning and Development or an individual designated as acting Commissioner ("**Commissioner**"):

(a) A written statement on the form attached hereto as Exhibit "B" stating that, conditioned upon proper notice to the Commissioner, Letter of Credit No. _____ will expire within 35 days or less and that the Customer has failed to deliver to the Commissioner evidence of a renewal of Letter of Credit No. _____; or

(b) A written statement on the form attached hereto as Exhibit "C" stating that all or any part of the public improvements required to be constructed pursuant to the Dearborn Firehouse Redevelopment Agreement dated _____, 2018 by and between the City of Chicago and EC 42 Developer LLC (the "**Agreement**") have not been constructed in accordance with the Agreement; or

(c) A written statement on the form attached hereto as Exhibit "D" stating that all or any part of the costs, payments, permit fees or other fees required to be paid to the City pursuant to the Agreement have not been paid in accordance with the Agreement; or

(d) A written statement on the form attached hereto as Exhibit "E" stating that all or any portion of the maintenance, repair, or restoration required to be performed pursuant to the Agreement has not been performed in accordance with the Agreement; or

(e) A written statement on the form attached hereto as Exhibit "F" stating that all or any portion of the Customer's undertakings pursuant to the Agreement have not been performed in accordance with the Agreement.

WE HEREBY AGREE with the beneficiary that:

1. Drafts drawn under and in compliance with this Letter of Credit shall be duly honored immediately upon presentation to us if presented on or before the above-stated Expiration Date or presented at our office together with the original of this Letter of Credit on or before that date. Further, one or more drafts may be presented at our office on or before the Expiration Date.

2. If, within three banking days after any draft drawn under this Letter of Credit is presented to us in conformance with the terms of this Letter of Credit, we fail to honor same, we agree to pay all attorneys' fees, court costs and other expenses incurred by the City in enforcing the terms hereof.

3. This Letter of Credit shall expire on _____, 20____, as stated hereinabove; provided, however, that we shall send notice to the Commissioner by certified mail, return receipt requested, or hand-delivered courier at least 35 days prior to said Expiration Date, that this Letter of Credit is about to expire.

4. In no event shall this Letter of Credit or the obligations contained herein expire except upon the prior written notice required herein, it being expressly agreed that the above expiration date shall be extended as shall be required to comply with the prior written notice required herein.

5. No consent, acknowledgment, or approval of any kind from the Customer shall be necessary or required prior to honoring any draft presented in conformance with the terms of this Letter of Credit.

6. The aggregate amount of this Letter of Credit may be reduced only upon receipt by us of a document executed by the Commissioner stating that such aggregate amount shall be reduced in an amount permitted because of the satisfactory completion of all or part of the improvements required to be constructed pursuant to the Agreement.

7. This Letter of Credit is irrevocable.

This Letter of Credit shall be governed by and construed in accordance with the Uniform Customs and Practices for ISP 98 of the International Chamber of Commerce (the "Uniform Customs"). In the event of a conflict between this Letter of Credit and the Uniform Customs, this Letter of Credit shall control. This Letter of Credit shall be deemed to be a contract made under the laws of the State of Illinois, including, without limitation, Article 5 of the Uniform Commercial Code as in effect in the State of Illinois, and shall, as to matters not governed by the Uniform Customs, be governed by and construed in accordance with the laws of the State of Illinois, without regard to principles of conflicts of law.

AS USED HEREIN, THE TERM "BANKING DAY" MEANS ANY DAY OTHER THAN A SATURDAY, SUNDAY, OR A DAY ON WHICH BANKS IN THE STATE OF ILLINOIS ARE AUTHORIZED OR REQUIRED TO BE CLOSED, AND A DAY ON WHICH PAYMENTS CAN BE EFFECTED ON THE FEDWIRE SYSTEM.

[Signature of Bank Officer]

[Signature of Bank Officer]

[Officer's Title]

[Officer's Title]

EXHIBIT "A" TO FORM OF IRREVOCABLE STANDBY LETTER OF CREDIT

FORM OF DRAFT

[To Be Supplied By Issuing Bank]

EXHIBIT "B" TO FORM OF IRREVOCABLE STANDBY LETTER OF CREDIT

To:
Attn:

Re: Letter of Credit No. _____

Ladies and Gentlemen:

This is to advise you that Letter of Credit No. _____ dated _____, 20____ in the amount of \$_____ will expire within 35 days or less and that _____ has failed to deliver to the Commissioner evidence of a renewal of Letter of Credit No. _____.

Very truly yours,

Commissioner of the Department of Planning and
Development, City of Chicago

EXHIBIT "C" TO FORM OF IRREVOCABLE STANDBY LETTER OF CREDIT

To:
Attn:

Re: Letter of Credit No. _____

Ladies and Gentlemen:

This is to advise you that all or any part of the improvements required to be constructed pursuant to the Dearborn Firehouse Redevelopment Agreement dated _____, 20__ by and between the City of Chicago and EC 42 Developer LLC, have not been constructed in accordance with said Agreement.

Very truly yours,

Commissioner of the Department of
Planning and Development
City of Chicago

EXHIBIT "D" TO FORM OF IRREVOCABLE STANDBY LETTER OF CREDIT

To:
Attn:

Re: Letter of Credit No. _____

Ladies and Gentlemen:

This is to advise you that all or any part of the costs, payments, permit fees or other fees required, to be paid pursuant to the Dearborn Firehouse Redevelopment Agreement dated _____, 20__ by and between the City of Chicago and EC 42 Developer LLC have not been paid in accordance with said Agreement.

Very truly yours,

Commissioner of the Department of
Planning and Development
City of Chicago

EXHIBIT "E" TO FORM OF IRREVOCABLE STANDBY LETTER OF CREDIT

To:
Attn:

Re: Letter of Credit No. _____

Ladies and Gentlemen:

This is to advise you that all or any part of the maintenance, repair or restoration required to be performed pursuant to the Dearborn Firehouse Redevelopment Agreement dated _____, 20____ by and between the City of Chicago and EC 42 Developer LLC, have not been performed in accordance with said Agreement.

Very truly yours,

Commissioner of the Department of
Planning and Development
City of Chicago

EXHIBIT "F" TO FORM OF IRREVOCABLE STANDBY LETTER OF CREDIT

To:
Attn:

Re: Letter of Credit No. _____

Ladies and Gentlemen:

This is to advise you that all or any part of the undertakings of the Customer (as that term is defined in the above-referenced Letter of Credit) pursuant to the Dearborn Firehouse Redevelopment Agreement dated _____, 20____ by and between the City of Chicago and EC 42 Developer LLC have not been performed in accordance with said Agreement.

Very truly yours,

City Manager

EXHIBIT II

MAINTENANCE AND GUARANTEE LETTER OF CREDIT

IRREVOCABLE LETTER OF CREDIT NO. _____ AMOUNT: _____

EXPIRATION DATE: _____ DATE OF ISSUE: _____

[Name of Bank]

[Address]

TO: City of Chicago
121 N. LaSalle Street
Chicago, Illinois 60602
Attention: _____

WE HEREBY AUTHORIZE YOU TO DRAW AT SIGHT on this Irrevocable Standby Letter of Credit No. _____ UP TO AN AGGREGATE AMOUNT OF _____ United States Dollars (\$ _____) for account of **EC 42 DEVELOPER LLC** (the "**Customer**").

Drafts under this Letter of Credit shall bear upon their face the words:

"Drawn under _____
Credit No. _____ Dated: _____"

Drafts may be for all or any portion of the amount of this Letter of Credit, and shall be in the form attached hereto as Exhibit "A" and shall be accompanied by one of the following documents executed by the City's Commissioner of the Department of Planning and Development or an individual designated as acting Commissioner ("**Commissioner**"):

(a) A written statement on the form attached hereto as Exhibit "B" stating that, conditioned upon proper notice to the Commissioner, Letter of Credit No. _____ will expire within 35 days or less and that the Customer has failed to deliver to the Commissioner evidence of a renewal of Letter of Credit No. _____; or

(b) A written statement on the form attached hereto as Exhibit "C" stating that all or any part of the public improvements required to be constructed pursuant to the Dearborn Firehouse Redevelopment Agreement dated _____, 2018 by and between the City of Chicago and EC 42 Developer LLC (the "**Agreement**") have not been constructed in accordance with the Agreement; or

(c) A written statement on the form attached hereto as Exhibit "D" stating that all or any part of the costs, payments, permit fees or other fees required to be paid to the City pursuant to the Agreement have not been paid in accordance with the Agreement; or

(d) A written statement on the form attached hereto as Exhibit "E" stating that all or any portion of the maintenance, repair, or restoration required to be performed pursuant to the Agreement has not been performed in accordance with the Agreement; or

(e) A written statement on the form attached hereto as Exhibit "F" stating that all or any portion of the Customer's undertakings pursuant to the Agreement have not been performed in accordance with the Agreement.

WE HEREBY AGREE with the beneficiary that:

1. Drafts drawn under and in compliance with this Letter of Credit shall be duly honored immediately upon presentation to us if presented on or before the above-stated Expiration Date or presented at our office together with the original of this Letter of Credit on or before that date. Further, one or more drafts may be presented at our office on or before the Expiration Date.

2. If, within three banking days after any draft drawn under this Letter of Credit is presented to us in conformance with the terms of this Letter of Credit, we fail to honor same, we agree to pay all attorneys' fees, court costs and other expenses incurred by the City in enforcing the terms hereof.

3. This Letter of Credit shall expire on _____, 20____, as stated hereinabove; provided, however, that we shall send notice to the Commissioner by certified mail, return receipt requested, or hand-delivered courier at least 35 days prior to said Expiration Date, that this Letter of Credit is about to expire.

4. In no event shall this Letter of Credit or the obligations contained herein expire except upon the prior written notice required herein, it being expressly agreed that the above expiration date shall be extended as shall be required to comply with the prior written notice required herein.

5. No consent, acknowledgment, or approval of any kind from the Customer shall be necessary or required prior to honoring any draft presented in conformance with the terms of this Letter of Credit.

6. The aggregate amount of this Letter of Credit may be reduced only upon receipt by us of a document executed by the Commissioner stating that such aggregate amount shall be reduced in an amount permitted because of the satisfactory completion of all or part of the improvements required to be constructed pursuant to the Agreement.

7. This Letter of Credit is irrevocable.

This Letter of Credit shall be governed by and construed in accordance with the Uniform Customs and Practices for ISP 98 of the International Chamber of Commerce (the "Uniform Customs"). In the event of a conflict between this Letter of Credit and the Uniform Customs, this Letter of Credit shall control. This Letter of Credit shall be deemed to be a contract made under the laws of the State of Illinois, including, without limitation, Article 5 of the Uniform Commercial Code as in effect in the State of Illinois, and shall, as to matters not governed by the Uniform Customs, be governed by and construed in accordance with the laws of the State of Illinois, without regard to principles of conflicts of law.

AS USED HEREIN, THE TERM "BANKING DAY" MEANS ANY DAY OTHER THAN A SATURDAY, SUNDAY, OR A DAY ON WHICH BANKS IN THE STATE OF ILLINOIS ARE AUTHORIZED OR REQUIRED TO BE CLOSED, AND A DAY ON WHICH PAYMENTS CAN BE EFFECTED ON THE FEDWIRE SYSTEM.

[Signature of Bank Officer]

[Signature of Bank Officer]

[Officer's Title]

[Officer's Title]

EXHIBIT "A" TO FORM OF IRREVOCABLE STANDBY LETTER OF CREDIT

FORM OF DRAFT

[To Be Supplied By Issuing Bank]

EXHIBIT "B" TO FORM OF IRREVOCABLE STANDBY LETTER OF CREDIT

To:
Attn:

Re: Letter of Credit No. _____

Ladies and Gentlemen:

This is to advise you that Letter of Credit No. _____ dated _____, 20____ in the amount of \$_____ will expire within 35 days or less and that _____ has failed to deliver to the Commissioner evidence of a renewal of Letter of Credit No. _____.

Very truly yours,

Commissioner of the Department of Planning and
Development, City of Chicago

EXHIBIT "C" TO FORM OF IRREVOCABLE STANDBY LETTER OF CREDIT

To:
Attn:

Re: Letter of Credit No. _____

Ladies and Gentlemen:

This is to advise you that all or any part of the improvements required to be constructed pursuant to the Dearborn Firehouse Redevelopment Agreement dated _____, 20__ by and between the City of Chicago and EC 42 Developer LLC, have not been constructed in accordance with said Agreement.

Very truly yours,

Commissioner of the Department of
Planning and Development
City of Chicago

EXHIBIT "D" TO FORM OF IRREVOCABLE STANDBY LETTER OF CREDIT

To:
Attn:

Re: Letter of Credit No. _____

Ladies and Gentlemen:

This is to advise you that all or any part of the costs, payments, permit fees or other fees required to be paid pursuant to the Dearborn Firehouse Redevelopment Agreement dated _____, 20__ by and between the City of Chicago and EC 42 Developer LLC have not been paid in accordance with said Agreement.

Very truly yours,

Commissioner of the Department of
Planning and Development
City of Chicago

EXHIBIT "E" TO FORM OF IRREVOCABLE STANDBY LETTER OF CREDIT

To:
Attn:

Re: Letter of Credit No. _____

Ladies and Gentlemen:

This is to advise you that all or any part of the maintenance, repair or restoration required to be performed pursuant to the Dearborn Firehouse Redevelopment Agreement dated _____, 20____ by and between the City of Chicago and EC 42 Developer LLC, have not been performed in accordance with said Agreement.

Very truly yours,

Commissioner of the Department of
Planning and Development
City of Chicago

EXHIBIT "F" TO FORM OF IRREVOCABLE STANDBY LETTER OF CREDIT

To:
Attn:

Re: Letter of Credit No. _____

Ladies and Gentlemen:

This is to advise you that all or any part of the undertakings of the Customer (as that term is defined in the above-referenced Letter of Credit) pursuant to the Dearborn Firehouse Redevelopment Agreement dated _____, 20____ by and between the City of Chicago and EC 42 Developer LLC have not been performed in accordance with said Agreement.

Very truly yours,

City Manager



JOSEPH A. MOORE

ALDERMAN, 49TH WARD
7356 NORTH GREENVIEW AVENUE
CHICAGO, ILLINOIS 60626
TELEPHONE 773-338-5796
ward49@cityofchicago.org
www.ward49.com

**CITY COUNCIL
CITY OF CHICAGO**

COUNCIL CHAMBER

CITY HALL, ROOM 200
121 NORTH LASALLE STREET
CHICAGO, ILLINOIS 60602
TELEPHONE 312-744-3067

COMMITTEE MEMBERSHIPS

HOUSING AND REAL ESTATE
CHAIRMAN

BUDGET AND GOVERNMENT OPERATIONS

COMMITTEES, RULES AND ETHICS

EDUCATION AND CHILD DEVELOPMENT

FINANCE

HEALTH AND ENVIRONMENTAL PROTECTION

HUMAN RELATIONS

SPECIAL EVENTS, CULTURAL AFFAIRS AND RECREATION

December 12, 2018

To the President and Members of the City Council:

Your Committee on Housing and Real Estate, for which a meeting was held on November 29, 2018, having had under consideration the substitute ordinance introduced by Mayor Rahm Emanuel on November 29, 2018, this being the redevelopment agreement and transfer of City-owned property at 55 W. Illinois St. and 444 N. Dearborn Street, begs leave to recommend that Your Honorable Body Approve said ordinance transmitted herewith.

This recommendation was concurred in by a voice vote of all committee members present with no dissenting votes.

Respectfully submitted,

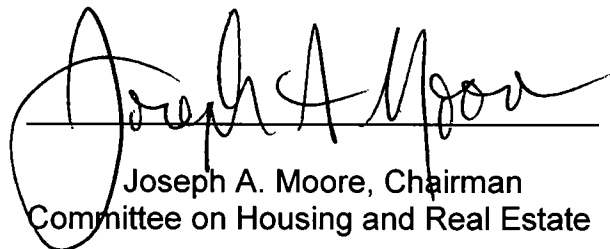

Joseph A. Moore, Chairman
Committee on Housing and Real Estate

