



Office of the Chicago City  
Clerk



O2012-3597

Office of the City Clerk

City Council Document Tracking Sheet

**Meeting Date:** 5/9/2012

**Sponsor(s):** Reilly, Brendan (42)

**Type:** Ordinance

**Title:** Grant(s) of privilege in public way for Jupiter Realty Corporation

**Committee(s) Assignment:** Committee on Transportation and Public Way

ORDINANCE  
JUPITER REALTY CORPORATION  
Acct. No. 298226 - 2  
Permit No. 1100618

*Be It Ordained by the City Council of the City of Chicago:*

SECTION 1. Permission and authority are hereby given and granted to JUPITER REALTY CORPORATION, upon the terms and subject to the conditions of this ordinance to maintain and use two (2) sign(s) projecting over the public right-of-way attached to its premises known as 215 W. Washington St..

Said sign structure(s) measures as follows; along W. Washington:  
Two (2) at two point five (2.5) feet in length, seven (7) feet in height and seventeen (17) feet above grade level.

The location of said privilege shall be as shown on prints kept on file with the Department of Business Affairs and Consumer Protection and the Office of the City Clerk.

Said privilege shall be constructed in accordance with plans and specifications approved by the Department of Transportation (Division of Project Development) and Zoning Department - Signs.

This grant of privilege in the public way shall be subject to the provisions of Section 10-28-015 and all other required provisions of the Municipal Code of Chicago.

The grantee shall pay to the City of Chicago as compensation for the privilege #1100618 herein granted the sum of one hundred seventy-five (\$175.00) per annum in advance.

A 25% penalty will be added for payments received after due date.

The permit holder agrees to hold the City of Chicago harmless for any damage, relocation or replacement costs associated with damage, relocation or removal of private property caused by the City performing work in the public way.

Authority herein given and granted for a period of five (5) years from and after Date of Passage.

Alderman \_\_\_\_\_

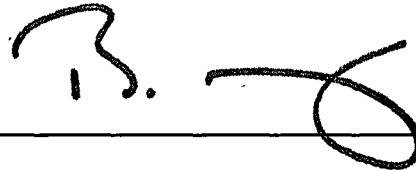

Brendan Reilly 42<sup>nd</sup> Ward

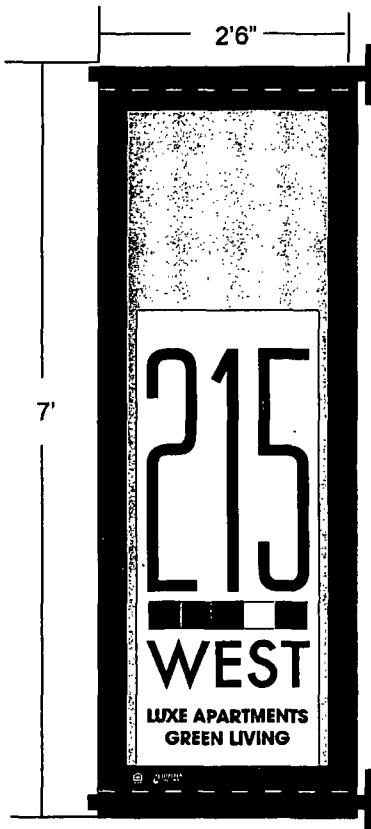

QTY 2 POLE POCKET BANNERS  
 \*2'6" OAH X 7' OAW  
 \*2" ROUND STEEL POLES  
 \*6"X6X1/4" STEEL PLATES  
 \*POLES AND PLATES ARE POWDER COATED STEEL

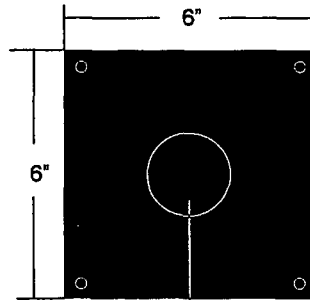

2" ROUND POLES

- This proof of FINAL artwork will be used to produce your order.
- Once you have signed your proof we will proceed with your order unless otherwise instructed to make changes.
- Your signature and date are REQUIRED before we can proceed with your order.
- PLEASE CHECK THE APPROPRIATE BOX AND SIGN & DATE BELOW.
- PRODUCTION SCHEDULES BEGIN UPON APPROVAL.
- Please remember that by signing and returning this proof, you assume responsibility for any grammar, punctuation, spelling, layout or color errors that may occur.

Sign: \_\_\_\_\_ Date: \_\_\_\_\_

APPROVED AS-IS     APPROVED WITH CORRECTIONS NOTED

CORRECTIONS NEEDED or NEW PROOF REQUIRED

**SOUTH WATER SIGNS**  
 122 North Oak Street  
 Chicago, IL 60610  
 Phone: (312) 407-1100 Fax: (312) 407-1101  
 www.southwatersigns.com

**215 W WASHINGTON**

JOB#: 32679  
 SALES REP: NOAH PETTIT  
 DESIGNER/PM: NICOLE MOYA

Start Date: 3.2.12  
 Last Revision: 00.00.00

Location:  
 215 W WASHINGTON  
 CHICAGO, IL

