



City of Chicago



O2017-3137

Office of the City Clerk

Document Tracking Sheet

Meeting Date: 4/12/2017

Sponsor(s): Reilly (42)

Type: Ordinance

Title: Grant(s) of privilege in public way for The Indian Garden Restaurant - sign

Committee(s) Assignment: Committee on Transportation and Public Way

ORDINANCE

The Indian Garden Restaurant
Acct. No. 296938 - 1
Permit No. 1127004

Be It Ordained by the City Council of the City of Chicago:

SECTION 1. Permission and authority are hereby given and granted to The Indian Garden Restaurant, upon the terms and subject to the conditions of this ordinance to maintain and use one (1) sign(s) projecting over the public right-of-way attached to its premises known as 247 E. Ontario St..

Said sign structure(s) measures as follows; along E. Ontario St.:
One (1) at two point three three (2.33) feet in length, eight (8) feet in height and twelve (12) feet above grade level.

The location of said privilege shall be as shown on prints kept on file with the Department of Business Affairs and Consumer Protection and the Office of the City Clerk.

Said privilege shall be constructed in accordance with plans and specifications approved by the Department of Transportation (Division of Project Development) and Zoning Department - Signs.

This grant of privilege in the public way shall be subject to the provisions of Section 10-28-015 and all other required provisions of the Municipal Code of Chicago.

The grantee shall pay to the City of Chicago as compensation for the privilege #1127004 herein granted the sum of one hundred (\$100.00) per annum in advance.

A 25% penalty will be added for payments received after due date.

The permit holder agrees to hold the City of Chicago harmless for any damage, relocation or replacement costs associated with damage, relocation or removal of private property caused by the City performing work in the public way.

Authority herein given and granted for a period of five (5) years from and after 01/18/2017.

Alderman _____

Brendan Reilly 42nd Ward

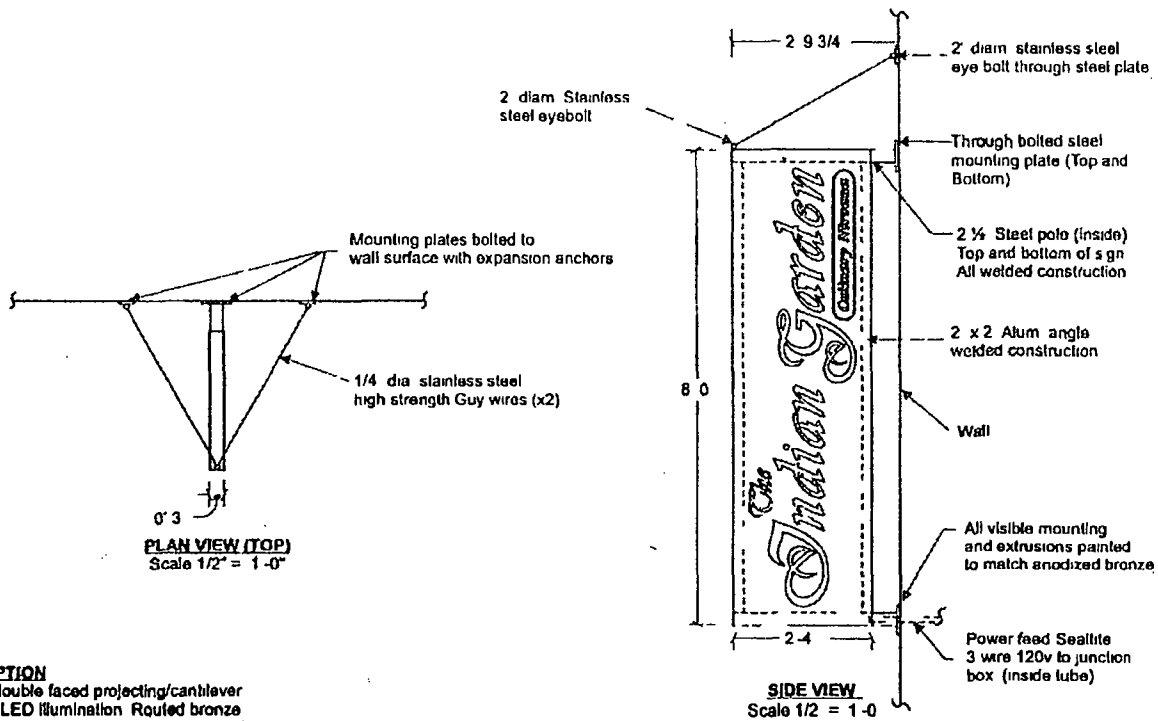

DESCRIPTION

One (1) double faced projecting/cantilever sign with LED illumination Routed bronze anodized aluminum faces with white translucent acrylic backer for lettering (DSG to provide material samples)

TOTAL SIGN AREA
= 18.5 sq Ft

NOTE
120 v POWER SUPPLY UL LISTED

Approved
Date

DeSignGroup Signage Corp
2155 S Frontage Rd
Des Plaines IL 60018
847 390-6350 fax 847-390-9231
gls@designgroupcorp.com

4376-1
Schatz Dev
Indian Garden

Drawn By PD

These plans are exclusive property of DesignGroup Signage Corp and are the result of the original work of its employees. They are submitted to your company for the sole purpose of your consideration as to whether to purchase these plans or to purchase from DesignGroup Signage Corp sign manufactured according to these plans. Distribution or exhibition of these plans to construct a sign similar to the one herein is strictly forbidden. In the event that such exhibition occurs DesignGroup Signage Corp plans to be reimbursed \$200.00 in compensation for time and cost expended in creating these plans.

Name	Date	Notes
PD	08 21 2011	Initial Sign Drawings
PD	08 28 2011	Coord and mounting detail
PD	10 25 2011	Call out revisions

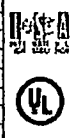



Department of Business Affairs and Consumer Protection
Small Business Center - Public Way Use Unit
City Hall - 121 N LaSalle Street, Room 800 • Chicago, IL 60602
312-74-GOBIZ / 312-744-6249 • (312) 744-1944 (TTY)
<http://www.cityofchicago.org/bacp>

03/29/2017

Alderman **Brendan Reilly**
Ward # 42
City of Chicago
City Hall, Room 300
121 North LaSalle Street
Chicago, Illinois 60602

Re: An ordinance to use and maintain a portion of the public right-of-way for **one (1) sign(s)** for **The Indian Garden Restaurant**, adjacent to the premises known as **247 E. Ontario St.**

Dear Alderman **Brendan Reilly**:

The applicant referenced above has requested the use of the public right-of-way for a **sign(s)**. An ordinance has been prepared by the Department of Business Affairs and Consumer Protection – Small Business Center - Public Way Use Unit for presentation to the City Council. Because this request was made for properties located in your ward, as approved by you as per the attached, I respectfully request that you introduce the attached ordinance at the next City Council meeting.

If you have any questions regarding this ordinance, please contact Anthony Bertuca at (312) 744-5506.

Department of Business Affairs and Consumer Protection