



# City of Chicago



O2013-8755

Office of the City Clerk

## Document Tracking Sheet

<b>Meeting Date:</b>	11/13/2013
<b>Sponsor(s):</b>	Fioretti (2)
<b>Type:</b>	Ordinance
<b>Title:</b>	Awning(s) for Fairlife
<b>Committee(s) Assignment:</b>	Committee on Transportation and Public Way

ORDINANCE  
FAIRLIFE  
Acct. No. 384721 - 1  
Permit No. 1109118

*Be It Ordained by the City Council of the City of Chicago:*

SECTION 1. Permission and authority are hereby given and granted to FAIRLIFE, upon the terms and subject to the conditions of this ordinance to construct, install, maintain and use one (1) Awning(s) projecting over the public right-of-way adjacent to its premises known as 1001 W. Adams St..

Said Awning(s) at W ADAMS ST measure(s):

One (1) at five (5) feet in length, and two (2) feet in width for a total of ten (10) square feet.

The location of said privilege shall be as shown on prints kept on file with the Department of Business Affairs and Consumer Protection and the Office of the City Clerk.

Said privilege shall be constructed in accordance with plans and specifications approved by the Zoning Department - Signs.

This grant of privilege in the public way shall be subject to the provisions of Section 10-28-015 and all other required provisions of the Municipal Code of Chicago.

The grantee shall pay to the City of Chicago as compensation for the privilege #1109118 herein granted the sum of fifty (\$50.00) per annum in advance.

A 25% penalty will be added for payments received after due date.

The permit holder agrees to hold the City of Chicago harmless for any damage, relocation or replacement costs associated with damage, relocation or removal of private property caused by the City performing work in the public way.

Authority herein given and granted for a period of five (5) years from and after Date of Passage.

Alderman



Bob Fioretti 2nd Ward

Rendering

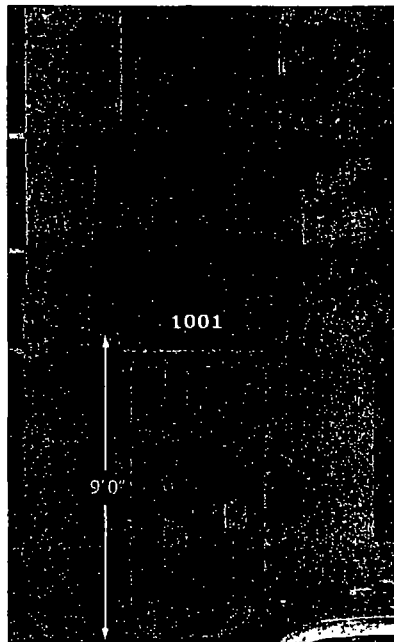

End view

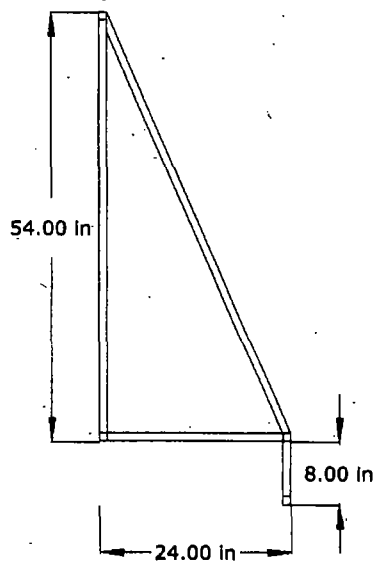

Isometric view

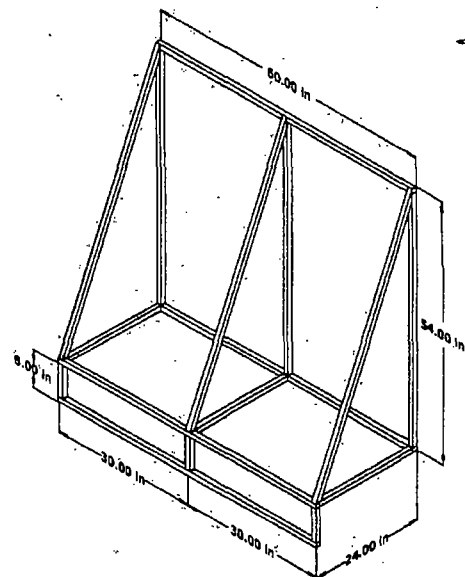

Notes:

- Render depicts awning with Black Sunbrella fabric and address number on valance.
- Awning frame is constructed of 1"x1" extruded, welded aluminum, using staple-in fabric.
- Frame dimensions: 4'6" Drop, 2' Projection, 5' Wide, 8" Rigid Valance.
- Bottom of awing is 9' from grade

**ATTENTION: PROOF ALL DRAWINGS CAREFULLY! IT IS THE RESPONSIBILITY OF THE CUSTOMER TO APPROVE COLOR, STYLE, SHAPE, PROPORTION OF GRAPHICS AND LOGOS, AND SPELLING OF TRADEMARKS AND SERVICE MARKS**

 <p>1432 Belmont Drive, Suite B   Addison, IL 60101 T 630-634-1438 F 630-634-1435</p>	<p><b>We've got you covered!</b></p> <ul style="list-style-type: none"> <li>Design</li> <li>Production</li> <li>Installation &amp; Power</li> <li>Programming</li> <li>Shipping</li> <li>Project Management</li> <li>Awnings</li> <li>Bill Signs</li> <li>Channel Letters</li> <li>Digitally Printed Graphics</li> <li>Decorative Signs</li> <li>Electronic Message Centers</li> <li>Marquee Signs</li> <li>ADP Signs</li> <li>Backlighting Signs</li> <li>Instrument Signs</li> <li>Service Signs</li> <li>Menu</li> <li>Plan Signs</li> <li>Photo &amp; Period Signs</li> <li>Projecting Wall Signs</li> <li>Public Signs</li> <li>Roll-Up Dimensional Lettering</li> <li>Way Displays</li> </ul>	<p>Project/Location: FairLife 1001 West Adams Chicago, IL</p>	<p>ACCOUNT REP: KENT WEBER PROJECT MANAGER: KENT STONEBURNER DRAWN BY: E. SADDLER</p>	<p>DATE: 09/21/2013</p>	<p>REVISIONS:</p> <table border="1"> <tr><td> </td><td> </td></tr> <tr><td> </td><td> </td></tr> <tr><td> </td><td> </td></tr> <tr><td> </td><td> </td></tr> </table> <p><small>Colors specified in this rendering may not exactly match finished products. Refer to product samples for exact color match.</small></p> <p>CLIENT APPROVAL DATE: _____ LANDSCAPE APPROVAL DATE: _____</p>								
<p>ALL ELECTRICAL SIGNS ARE TO COMPLY WITH U.L. 48 AND ARTICLE 600 OF THE N.E.C. STANDARDS, INCLUDING THE PROPER GROUNDING AND BONDING OF ALL SIGNS.</p>			<p>SCALE: _____</p>	<p>SHEET #: _____</p>									
<p><small>Underwriters Laboratories, Inc.</small></p>			<p><small>ELECTRICAL TO U.S. UL LISTED COMPONENTS AND SHALL MEET ALL N.E.C. STANDARDS.</small></p>	<p>DESIGN ORDER #: _____</p>									
<p><small>This original drawing is provided as part of a planned project and is not to be exhibited, copied or reproduced without the written permission of Awning Sign &amp; Lighting Group, Inc or its authorized agent. © 2012</small></p>			<p>FILE NAME: _____</p>	<p> </p>									



**11/13/2013**

Alderman **Bob Fioretti**  
Ward # **02**  
City of Chicago  
City Hall, Room **300**  
121 North LaSalle Street  
Chicago, Illinois 60602

Re: An ordinance to use and maintain a portion of the public right-of-way for **one (1) awning(s)** for **FAIRLIFE**, adjacent to the premises known as **1001 W. Adams St..**

Dear Alderman **Bob Fioretti**:

The applicant referenced above has requested the use of the public right-of-way for a **awning(s)**. An ordinance has been prepared by the Department of Business Affairs and Consumer Protection – Business Assistance Center - Public Way Use Unit for presentation to the City Council. Because this request was made for properties located in your ward, as approved by you as per the attached, I respectfully request that you introduce the attached ordinance at the next City Council meeting.

If you have any questions regarding this ordinance, please contact Anthony Bertuca at (312) 744-5506.

**Department of Business Affairs and Consumer Protection**