



City of Chicago



O2017-3134

Office of the City Clerk

Document Tracking Sheet

Meeting Date: 4/12/2017
Sponsor(s): Reilly (42)
Type: Ordinance
Title: Grant(s) of privilege in public way for The Halal Guys - sign
Committee(s) Assignment: Committee on Transportation and Public Way

ORDINANCE
THE HALAL GUYS
Acct. No. 399869 - 3
Permit No. 1124042

Be It Ordained by the City Council of the City of Chicago:

SECTION 1. Permission and authority are hereby given and granted to THE HALAL GUYS, upon the terms and subject to the conditions of this ordinance to maintain and use three (3) sign(s) projecting over the public right-of-way attached to its premises known as 180 N. Wabash Ave..

Said sign structure(s) measures as follows; along N. Wabash Avenue:

Two (2) at nine point zero eight (9.08) feet in length, three point two five (3.25) feet in height and ten (10) feet above grade level.

One (1) at three (3) feet in length, two point five (2.5) feet in height and ten (10) feet above grade level.

The location of said privilege shall be as shown on prints kept on file with the Department of Business Affairs and Consumer Protection and the Office of the City Clerk.

Said privilege shall be constructed in accordance with plans and specifications approved by the Department of Transportation (Division of Project Development) and Zoning Department - Signs.

This grant of privilege in the public way shall be subject to the provisions of Section 10-28-015 and all other required provisions of the Municipal Code of Chicago.

The grantee shall pay to the City of Chicago as compensation for the privilege #1124042 herein granted the sum of seven hundred (\$700.00) per annum in advance.

A 25% penalty will be added for payments received after due date.

The permit holder agrees to hold the City of Chicago harmless for any damage, relocation or replacement costs associated with damage, relocation or removal of private property caused by the City performing work in the public way.

Authority herein given and granted for a period of five (5) years from and after Date of Passage.

Alderman _____

Brendan Reilly 42nd Ward



INNOVATION | ILLUMINATION | FABRICATION | INSTALLATION |
THE HALAL GUYS/BEAN AND LEAF 180 NORTH WABASH ST CHICAGO

SIDE SIGN

FRONT SIGN

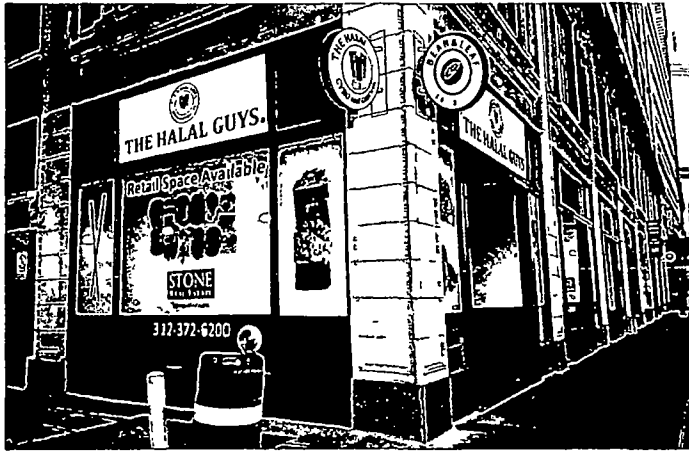

FRONT SIGN

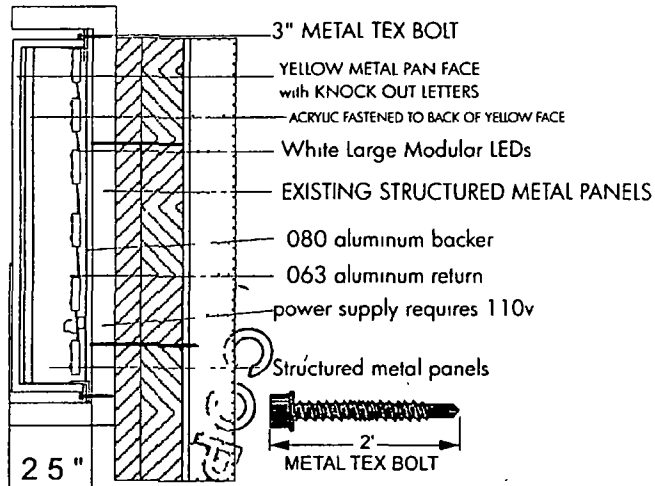
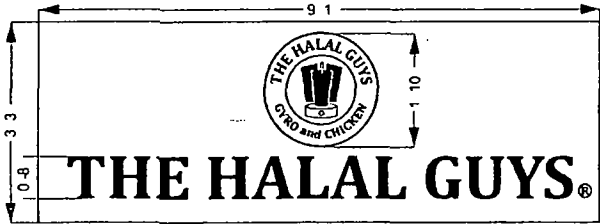

**Illuminated Sign Will Have A Dimmer
{And Only Operate During Business Hours

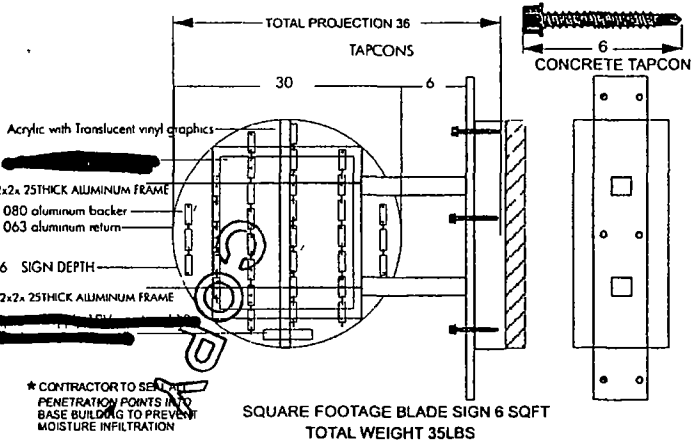

* CONTRACTOR TO SEAL
PENETRATION POINTS INTO
BASE BUILDING TO PREVENT
MOISTURE INFILTRATION

p: | 1-877-342-0847 p: | 519-442-0847 f: | 519-442-5580

abracadabrasigns.com





Department of Business Affairs and Consumer Protection
Small Business Center - Public Way Use Unit
City Hall - 121 N LaSalle Street, Room 800 • Chicago, IL 60602
312-74-GOBIZ / 312-744-6249 • (312) 744-1944 (TTY)
<http://www.cityofchicago.org/bacp>

03/29/2017

Alderman **Brendan Reilly**
Ward # 42
City of Chicago
City Hall, Room 300
121 North LaSalle Street
Chicago, Illinois 60602

Re: An ordinance to use and maintain a portion of the public right-of-way for **three (3) sign(s)** for **THE HALAL GUYS**, adjacent to the premises known as **180 N. Wabash Ave.**.

Dear Alderman **Brendan Reilly**:

The applicant referenced above has requested the use of the public right-of-way for a **sign(s)**. An ordinance has been prepared by the Department of Business Affairs and Consumer Protection – Small Business Center - Public Way Use Unit for presentation to the City Council. Because this request was made for properties located in your ward, as approved by you as per the attached, I respectfully request that you introduce the attached ordinance at the next City Council meeting.

If you have any questions regarding this ordinance, please contact Anthony Bertuca at (312) 744-5506.

Department of Business Affairs and Consumer Protection