



City of Chicago



O2019-7646

Office of the City Clerk

Document Tracking Sheet

Meeting Date:	9/18/2019
Sponsor(s):	Burnett (27)
Type:	Ordinance
Title:	Grant(s) of privilege in public way for 320 N Sangamon Owner LLC
Committee(s) Assignment:	Committee on Transportation and Public Way

ORDINANCE
320 N. SANGAMON OWNER, L.L.C.
Acct. No. 461289 - 1
Permit No. 1141776

Be It Ordained by the City Council of the City of Chicago:

SECTION 1. Permission and authority are hereby given and granted to 320 N SANGAMON OWNER, L L.C., upon the terms and subject to the conditions of this ordinance to construct, install, maintain and use one (1) Planter(s) on the public right-of-way for beautification purposes adjacent to its premises known as 320 N. Sangamon St..

Said Planter(s) at N. Sangamon measure(s):

One (1) at twenty-three (23) feet in length, and six (6) feet in width for a total of one hundred thirty-eight (138) square feet.

Grantee must allow the required clear and unobstructed space for pedestrian passage at all times per rules and regulations approved by the Department of Transportation.

The location of said privilege shall be as shown on prints kept on file with the Department of Business Affairs and Consumer Protection and the Office of the City Clerk.

Said privilege shall be constructed in accordance with plans and specifications approved by the Department of Planning and Development and Department of Transportation (Division of Project Development).

This grant of privilege in the public way shall be subject to the provisions of Section 10-28-015 and all other required provisions of the Municipal Code of Chicago.

The grantee shall pay to the City of Chicago as compensation for the privilege #1141776 herein granted the sum of zero (\$0.00) per annum in advance.

A 25% penalty will be added for payments received after due date.

The permit holder agrees to hold the City of Chicago harmless for any damage, relocation or replacement costs associated with damage, relocation or removal of private property caused by the City performing work in the public way.

Authority herein given and granted for a period of five (5) years from and after Date of Passage.

Alderman

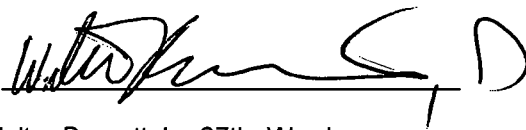

Walter Burnett Jr. 27th Ward

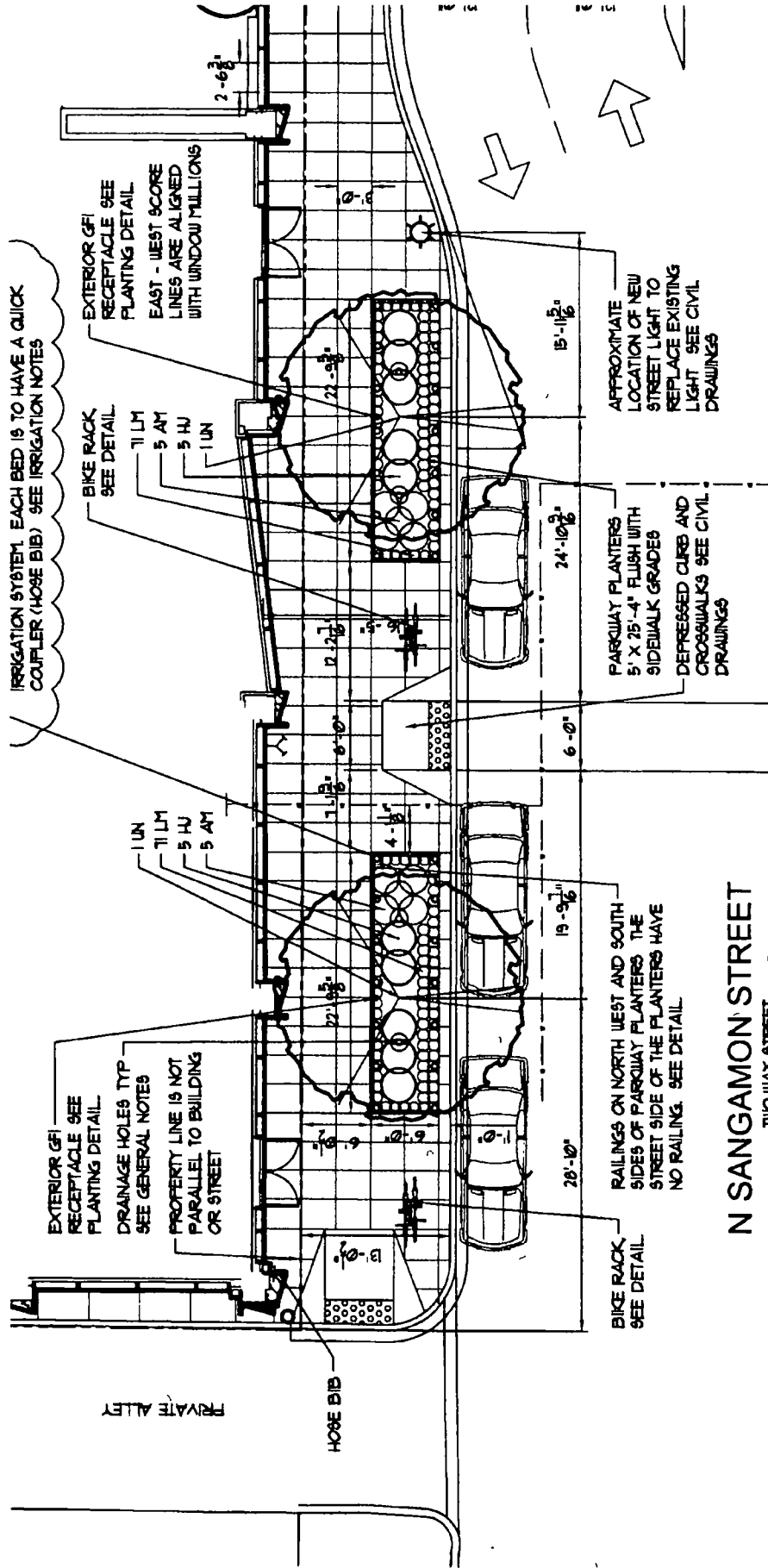

IRRIGATION SYSTEM. EACH BED IS TO HAVE A CLICK COUPLER (HOSE BIB) SEE IRRIGATION NOTES

EXTERIOR GFI RECEPTACLE SEE PLANTING DETAIL

DRAINAGE HOLES TYP SEE GENERAL NOTES

PROPERTY LINE IS NOT PARALLEL TO BUILDING OR STREET

BIKE RACK SEE DETAIL

1 UN
1 LM
5 HU
5 AM

EXTERIOR GFI RECEPTACLE SEE PLANTING DETAIL
EAST - WEST SCORE LINES ARE ALIGNED WITH WINDOW MULLIONS

BIKE RACK SEE DETAIL

RAILINGS ON NORTH WEST AND SOUTH SIDES OF PARKWAY PLANTERS THE STREET SIDE OF THE PLANTERS HAVE NO RAILING. SEE DETAIL

PARKWAY PLANTERS 5' X 25'-4" FLUSH WITH SIDEWALK GRADES DEPRESSED CURB AND CROSSWALKS SEE CIVIL DRAWINGS

APPROXIMATE LOCATION OF NEW STREET LIGHT TO REPLACE EXISTING LIGHT SEE CIVIL DRAWINGS

N SANGAMON STREET

— THIS IS A STREET —

PRIVATE ALLEY

HOSE BIB

15'-11¹/₂"

24'-10³/₈"

6'-0"

19'-9¹/₁₆"

28'-10"

12'-1¹/₂"

11'-1¹/₂"

4'-1¹/₂"

27'-1¹/₂"

22'-9³/₈"

2'-6³/₈"

