



City of Chicago



O2017-2712

Office of the City Clerk

Document Tracking Sheet

Meeting Date:	3/29/2017
Sponsor(s):	Reilly (42)
Type:	Ordinance
Title:	Grant(s) of privilege in public way for CHAMPS No. 15074 - sign
Committee(s) Assignment:	Committee on Transportation and Public Way

ORDINANCE
CHAMPS # 15074
Acct. No. 4535 - 76
Permit No. 1126022

Be It Ordained by the City Council of the City of Chicago:

SECTION 1. Permission and authority are hereby given and granted to CHAMPS # 15074, upon the terms and subject to the conditions of this ordinance to maintain and use one (1) sign(s) projecting over the public right-of-way attached to its premises known as 100-112 S. State St..

Said sign structure(s) measures as follows; along S. State:

One (1) at eighteen (18) feet in length, six point five (6.5) feet in height and thirteen point eight nine (13.89) feet above grade level.

The location of said privilege shall be as shown on prints kept on file with the Department of Business Affairs and Consumer Protection and the Office of the City Clerk.

Said privilege shall be constructed in accordance with plans and specifications approved by the Department of Transportation (Division of Project Development) and Zoning Department - Signs.

This grant of privilege in the public way shall be subject to the provisions of Section 10-28-015 and all other required provisions of the Municipal Code of Chicago.

The grantee shall pay to the City of Chicago as compensation for the privilege #1126022 herein granted the sum of three hundred (\$300.00) per annum in advance.

A 25% penalty will be added for payments received after due date.

The permit holder agrees to hold the City of Chicago harmless for any damage, relocation or replacement costs associated with damage, relocation or removal of private property caused by the City performing work in the public way.

Authority herein given and granted for a period of five (5) years from and after Date of Passage.

Alderman _____

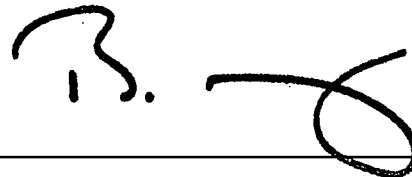

Brendan Reilly 42nd Ward

Contact 1900 Ocean Avenue Ronkonkoma NY 11779 P631 737 3140 F631 737 4865

Sign Type WALL CABINET | Description LED HALO ILLUMINATED | Quantity (1) | 10

A SINGLE FACE WALL SIGN
Scale 3/8" = 1'-0" (117'00 Sq Ft)

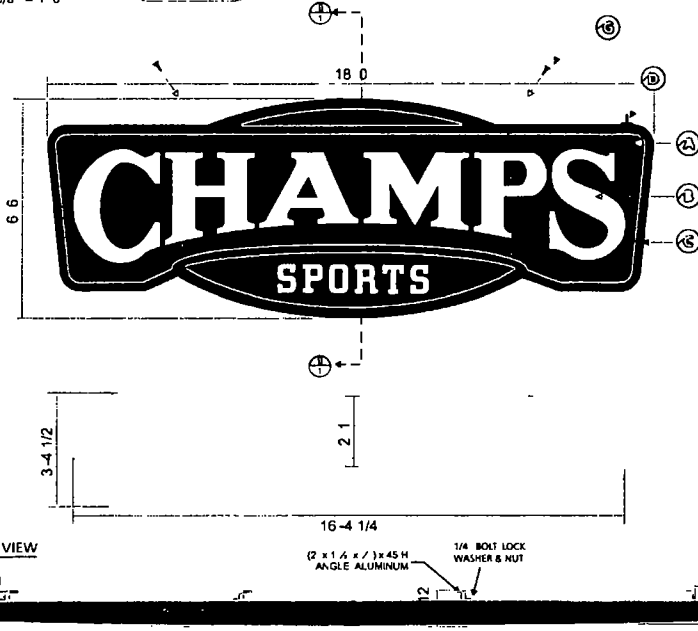

2 SIDE VIEW
Scale NTS

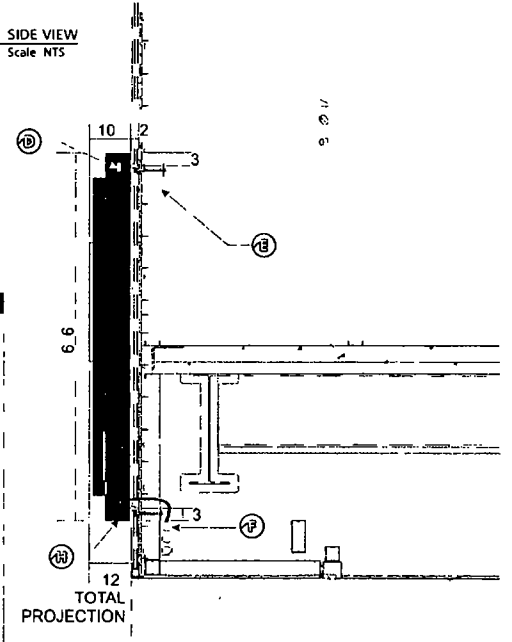

COLOR KEY

-  PMS 2747C SATIN
-  PMS 187C SATIN
-  2447 WHITE ACRYLIC

1 TOP VIEW
NTS

NOTES:
ELECTRICAL WIRING FROM SIGN WILL NEED TO BE WIRED INTO THE PRIMARY ELECTRICAL SOURCE. DEDICATED 120V AC CIRCUIT REQUIRED AND TO BE PROVIDED BY OTHERS PRIOR TO SIGN INSTALLATION.

NOTES:
ALL ELECTRICAL PARTS & ASSEMBLIES UL LISTED. UL LABELS TO BE LOCATED AT DISCONNECT SWITCH.

- 1** 1/8" Aluminum Routed & Compound Radius Face with Stencil Cut Copy Painted to Match PMS 2747C
- 2** 3/4" 2447 White Acrylic Push Thru Letters with 1/4" Flange (CHAMPS & SPORTS) Secured with Stud and Nut (Radius Face)
- 3** Red Accent Lines on Face Painted to Match Red PMS 187C
- 4** Disconnect Switch/UL Labels
- 5** 1/4" 20 Thru bolts with fender washers lock washers nuts & threaded rod 2 x 1 1/2 x 1/8" angle aluminum PTM White
- 6** 120 V Feed By Others
- 7** Removable access panel with Magnetic attachment (2) counter sunk safety screws painted to match PMS 2747C
- 8** 1/4" Weep Hole w/ Light Baffle

1b **broadwaynational**

Job Name CHAMPS Date 06 14 16
Address 110 SOUTH STATE STREET Job Number 17853
CHICAGO IL 60603 Project Manager JP

Scale See Drawing
Drawn By KK
Revised 02 03 17 # 15 02

Approved Rejected
 Approved with Corrections Revise and Resubmit
Signature _____ Date _____

This artwork is the property of Broadway National. Unauthorized use, publication or distribution is prohibited.