



City of Chicago



O2017-8174

Office of the City Clerk

Document Tracking Sheet

Meeting Date:	11/8/2017
Sponsor(s):	Waguespack (32)
Type:	Ordinance
Title:	Awning(s) for Massage House
Committee(s) Assignment:	Committee on Transportation and Public Way

ORDINANCE
MESSAGE HOUSE
Acct. No. 365166 - 1
Permit No. 1128306

Be It Ordained by the City Council of the City of Chicago:

SECTION 1. Permission and authority are hereby given and granted to MESSAGE HOUSE, upon the terms and subject to the conditions of this ordinance to construct, install, maintain and use one (1) Awning(s) projecting over the public right-of-way adjacent to its premises known as 2405 N. Clybourn Ave..

Said Awning(s) at N. Clybourn Avenue measure(s):

One (1) at twenty (20) feet in length, and two (2) feet in width for a total of forty (40) square feet.

The location of said privilege shall be as shown on prints kept on file with the Department of Business Affairs and Consumer Protection and the Office of the City Clerk.

Said privilege shall be constructed in accordance with plans and specifications approved by the Zoning Department - Signs.

This grant of privilege in the public way shall be subject to the provisions of Section 10-28-015 and all other required provisions of the Municipal Code of Chicago.

The grantee shall pay to the City of Chicago as compensation for the privilege #1128306 herein granted the sum of fifty (\$50.00) per annum in advance.

A 25% penalty will be added for payments received after due date.

The permit holder agrees to hold the City of Chicago harmless for any damage, relocation or replacement costs associated with damage, relocation or removal of private property caused by the City performing work in the public way.

Authority herein given and granted for a period of five (5) years from and after Date of Passage.

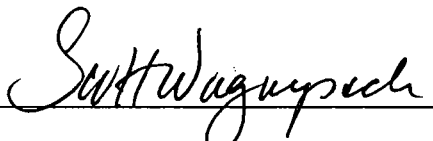
Alderman 
Scott Waguespack 32nd Ward

SIGN: AWNING

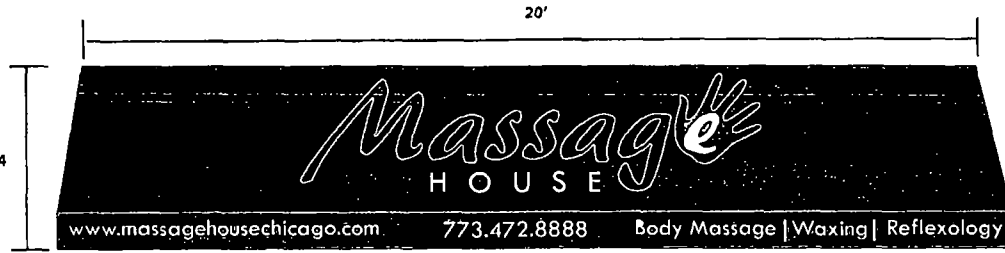

SPECIFICATIONS

- 1 AWNING FABRIC MATERIAL
- 2 1 X 1" SQUARE TUBE FRAME
- 3 3/16 GALVANIZED STEEL Z CLIP ATTACHMENT
- 4 APPROPRIATE NON CORROSIVE WALL FASTENER
3/8 IN ZINC PLATED HEX LAG SCREW
SPACING EACH 4 FT
SEE MOUNTING OPTION DETAILS
- 5 #12 TEK SCREW

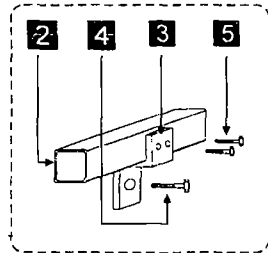
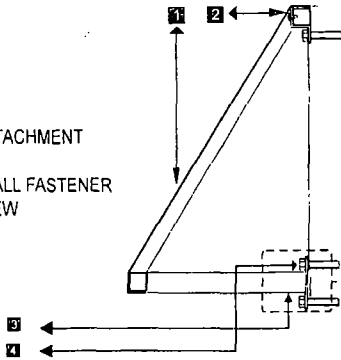

Z CLIP FOR INSTALLATION EVERY FOUR SIDED

COLOR SCHEDULE

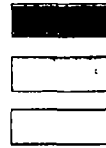

MOUNTING DETAIL

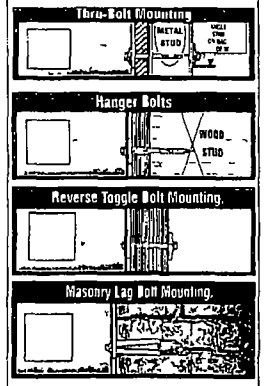

Client Name
Massage House

Location
2405 N Clybourn Ave
Chicago IL 60614

Start Date 05/08/17
Last Revision
Job#
Drawing#
Page 2/3

- Client Approval
- Landlord Approval

Sales Rep
kw
Designer
SL





11/08/2017

Alderman Scott Waguespack
Ward # **32**
City of Chicago
City Hall, Room **300**
121 North LaSalle Street
Chicago, Illinois 60602

Re: An ordinance to use and maintain a portion of the public right-of-way for **one (1) awning(s)** for **MASSAGE HOUSE**, adjacent to the premises known as **2405 N. Clybourn Ave.**.

Dear Alderman **Scott Waguespack**:

The applicant referenced above has requested the use of the public right-of-way for a **awning(s)**. An ordinance has been prepared by the Department of Business Affairs and Consumer Protection – Small Business Center - Public Way Use Unit for presentation to the City Council. Because this request was made for properties located in your ward, as approved by you as per the attached, I respectfully request that you introduce the attached ordinance at the next City Council meeting.

If you have any questions regarding this ordinance, please contact Anthony Bertuca at (312) 744-5506.

Department of Business Affairs and Consumer Protection

