



Office of the Chicago City
Clerk



O2011-7953

Office of the City Clerk

City Council Document Tracking Sheet

Meeting Date:	9/8/2011
Sponsor(s):	Pawar, Ameya (47)
Type:	Ordinance
Title:	Grant(s) of Privilege in Public Way for Bookcellar, The
Committee(s) Assignment:	Committee on Transportation and Public Way

ORDINANCE
THE BOOKCELLAR
Acct. No. 268915 - 1
Permit No. 1097668

Be It Ordained by the City Council of the City of Chicago:

SECTION 1. Permission and authority are hereby given and granted to THE BOOKCELLAR, upon the terms and subject to the conditions of this ordinance to maintain and use one (1) sign(s) projecting over the public right-of-way attached to its premises known as 4736-38 N. Lincoln Ave..

Said sign structure(s) measures as follows; along N Lincoln Ave:
One (1) at two (2) feet in length, one point five (1.5) feet in height and twelve (12) feet above grade level.

The location of said privilege shall be as shown on prints kept on file with the Department of Business Affairs and Consumer Protection and the Office of the City Clerk.

Said privilege shall be constructed in accordance with plans and specifications approved by the Department of Transportation (Division of Project Development) and Zoning Department - Signs.

This grant of privilege in the public way shall be subject to the provisions of Section 10-28-015 and all other required provisions of the Municipal Code of Chicago.

The grantee shall pay to the City of Chicago as compensation for the privilege #1097668 herein granted the sum of one hundred (\$100.00) per annum in advance.

A 25% penalty will be added for payments received after due date.

The permit holder agrees to hold the City of Chicago harmless for any damage, relocation or replacement costs associated with damage, relocation or removal of private property caused by the City performing work in the public way.

Authority herein given and granted for a period of five (5) years from and after 07/26/2011.

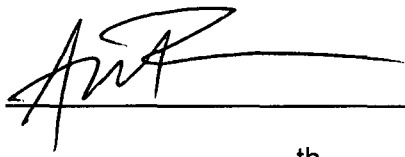
Alderman 
Ameya Pawar 47th Ward



NON ILLUMINATED PROJECTION SIGN

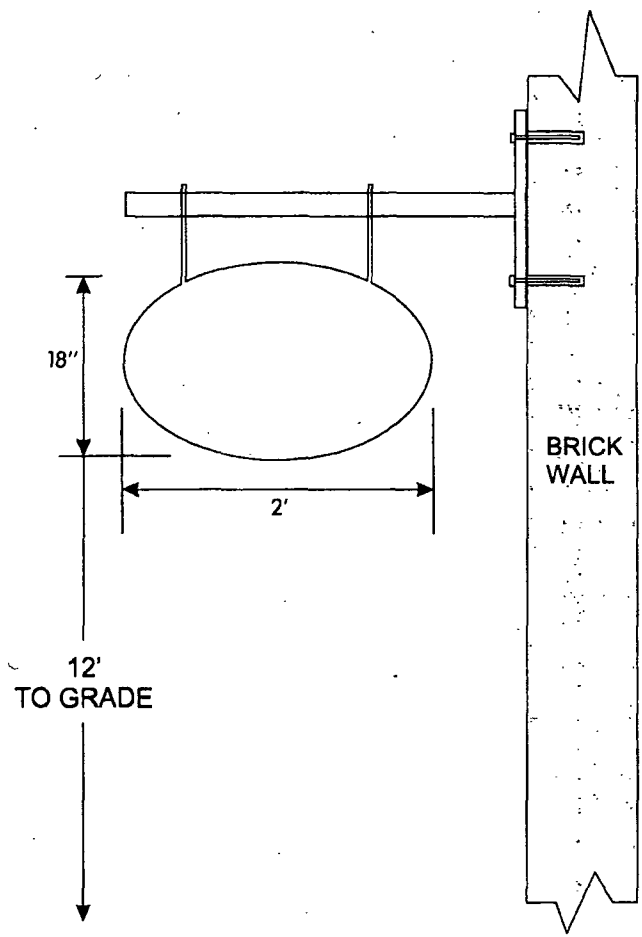

RB SIGNS
 4543 W. Addison
 Chicago IL. 60641
 PH. 773-736-0800
 FAX 773-736-4730

DESCRIPTION:	DOUBLE FACE NON ILLUMINATED PROJECTION SIGN
CUSTOMER:	BOOK CELLAR 4736 N. LINCOLN AVE. CHICAGO IL.
CUSTOMER ACCEPTANCE:	DATE: 7-19-11



09/08/2011

Alderman Ameya Pawar
Ward # 47
City of Chicago
City Hall, Room 300
121 North LaSalle Street
Chicago, Illinois 60602

Re: An ordinance to use and maintain a portion of the public right-of-way for **one (1) sign(s)** for **THE BOOKCELLAR**, adjacent to the premises known as **4736-38 N. Lincoln Ave.**.

Dear Alderman Ameya Pawar:

The applicant referenced above has requested the use of the public right-of-way for a **sign(s)**. An ordinance has been prepared by the Department of Business Affairs and Consumer Protection – Business Assistance Center - Public Way Use Unit for presentation to the City Council. Because this request was made for properties located in your ward, as approved by you as per the attached, I respectfully request that you introduce the attached ordinance at the next City Council meeting.

If you have any questions regarding this ordinance, please contact John Mariane, Manager, Business Assistance Center - Public Way Use Unit, at (312) 744-2063.

Department of Business Affairs and Consumer Protection