



# City of Chicago



O2014-1720

Office of the City Clerk

## Document Tracking Sheet

<b>Meeting Date:</b>	3/5/2014
<b>Sponsor(s):</b>	Waguespack (32)
<b>Type:</b>	Ordinance
<b>Title:</b>	Awning(s) for Journey Physical Therapy
<b>Committee(s) Assignment:</b>	Committee on Transportation and Public Way

City of Chicago  
Department of Business Affairs and Consumer Protection  
Public Way Use Unit  
Chicago, IL 60604  
ORDINANCE  
JOURNEY PHYSICAL THERAPY  
Acct. No. 378605-1  
Permit No. 1104498

City of Chicago  
Department of Business Affairs and Consumer Protection  
Public Way Use Unit  
Chicago, IL 60604  
ORDINANCE  
JOURNEY PHYSICAL THERAPY  
Acct. No. 378605-1  
Permit No. 1104498

City of Chicago  
Department of Business Affairs and Consumer Protection  
Public Way Use Unit  
Chicago, IL 60604  
ORDINANCE  
JOURNEY PHYSICAL THERAPY  
Acct. No. 378605-1  
Permit No. 1104498

Be It Ordained by the City Council of the City of Chicago:

SECTION 1. Permission and authority are hereby given and granted to JOURNEY PHYSICAL THERAPY, upon the terms and subject to the conditions of this ordinance to construct, install, maintain and use one (1) Awning(s) projecting over the public right-of-way adjacent to its premises known as 2250 W. Belmont Ave..

Said Awning(s) at W. Belmont measure(s):  
One (1) at fifteen (15) feet in length, and two (2) feet in width for a total of thirty (30) square feet.

The location of said privilege shall be as shown on prints kept on file with the Department of Business Affairs and Consumer Protection and the Office of the City Clerk.

Said privilege shall be constructed in accordance with plans and specifications approved by the Zoning Department - Signs.

This grant of privilege in the public way shall be subject to the provisions of Section 10-28-015 and all other required provisions of the Municipal Code of Chicago.

The grantee shall pay to the City of Chicago as compensation for the privilege #1104498 herein granted the sum of fifty (\$50.00) per annum in advance.

A 25% penalty will be added for payments received after due date.

The permit holder agrees to hold the City of Chicago harmless for any damage, relocation or replacement costs associated with damage, relocation or removal of private property caused by the City performing work in the public way.

Authority herein given and granted for a period of five (5) years from and after Date of Passage.

Alderman Scott Waguespaak  
Scott Waguespaak 32nd Ward

EL PRODUCT

PRO

ADDRESS OF AWNING  
2250 W. BELMONT

ADDRESS OF AWNING  
2250 W. BELMONT

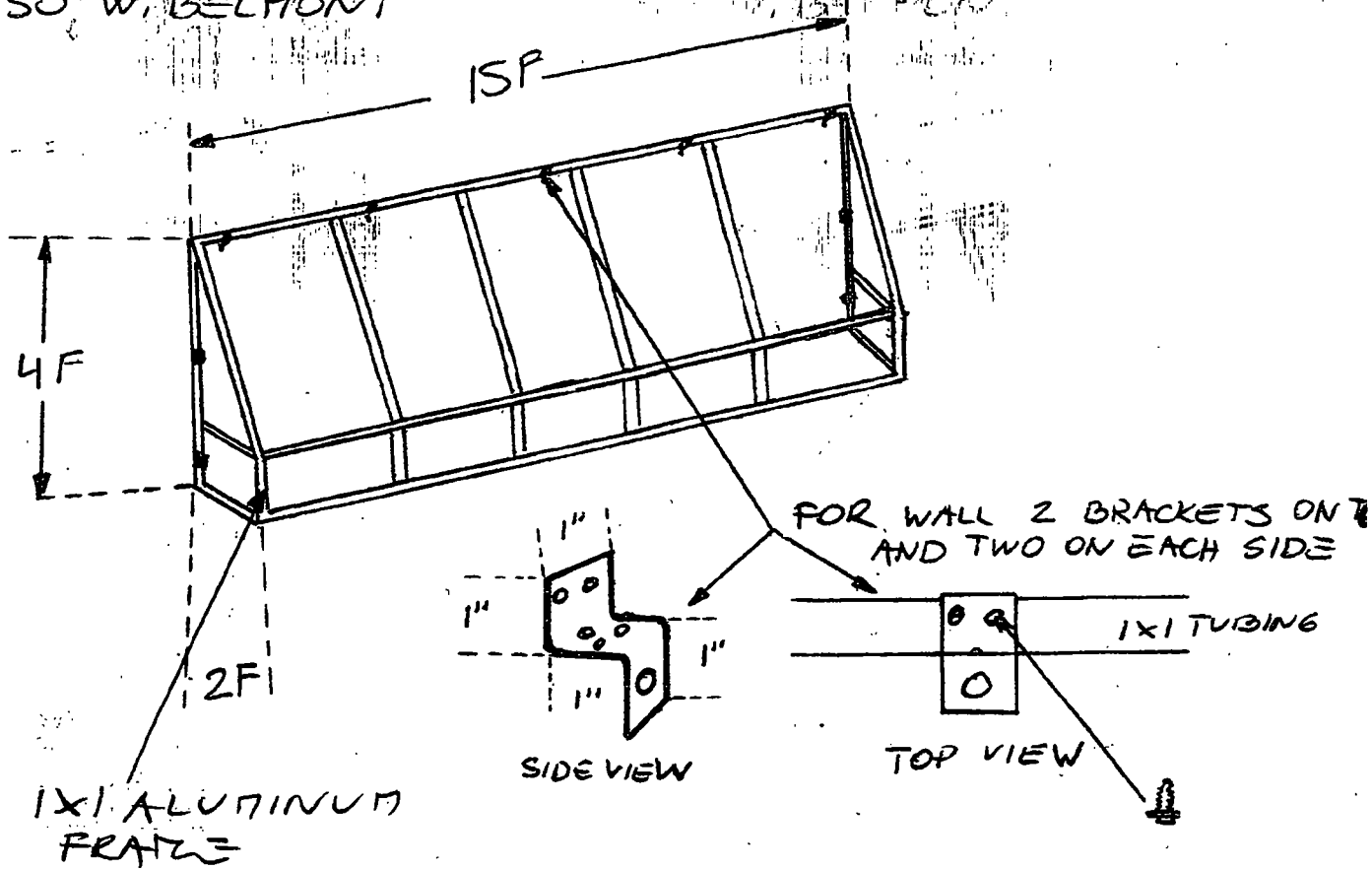

EXISTING MAIN FRAME MAKE OF 1x1 ALUMINUM TUBINGS

\* WE WILL RECOVER EXISTING FRAME WITH BLACK CANVAS

\* LOGO AND LETTERINGS WILL BE GOLD AND RED



Department of Business Affairs and Consumer Protection

Small Business Center - Public Way Use Unit

City Hall - 121 N. LaSalle Street, Room 800 • Chicago, IL 60602

(312)-74-GOBIZ (312-744-6249) • (312) 744-1944 (TTY)

<http://www.cityofchicago.org/bacp>

03/05/2014

Alderman **Scott Waguespack**

Ward # **32**

City of Chicago

City Hall, Room **300**

121 North LaSalle Street

Chicago, Illinois 60602

Re: An ordinance to use and maintain a portion of the public right-of-way for **one (1) awning(s)** for **JOURNEY PHYSICAL THERAPY**, adjacent to the premises known as **2250 W. Belmont Ave.**.

Dear Alderman **Scott Waguespack**:

The applicant referenced above has requested the use of the public right-of-way for a **awning(s)**. An ordinance has been prepared by the Department of Business Affairs and Consumer Protection – Small Business Center - Public Way Use Unit for presentation to the City Council. Because this request was made for properties located in your ward, as approved by you as per the attached, I respectfully request that you introduce the attached ordinance at the next City Council meeting.

If you have any questions regarding this ordinance, please contact Anthony Bertuca at (312) 744-5506.

**Department of Business Affairs and Consumer Protection**