



City of Chicago



O2015-5948

Office of the City Clerk

Document Tracking Sheet

Meeting Date:	7/29/2015
Sponsor(s):	Reilly (42)
Type:	Ordinance
Title:	Grant(s) of privilege in public way for MRR 678 Kingsbury LLC
Committee(s) Assignment:	Committee on Transportation and Public Way

ORDINANCE
MRR 678 Kingsbury LLC
Acct. No. 396746 - 1
Permit No. 1119182

Be It Ordained by the City Council of the City of Chicago:

SECTION 1. Permission and authority are hereby given and granted to MRR 678 Kingsbury LLC, upon the terms and subject to the conditions of this ordinance to construct, install, maintain and use one (1) Grease Separator(s) under the public right-of-way adjacent to its premises known as 676 N. Kingsbury St..

Said Grease Separator(s) at N. Kingsbury Street measure(s):

One (1) at eight point six seven (8.67) feet in length, and five point one seven (5.17) feet in width for a total of forty-four point eight two (44.82) square feet.

The location of said privilege shall be as shown on prints kept on file with the Department of Business Affairs and Consumer Protection and the Office of the City Clerk.

Said privilege shall be constructed in accordance with plans and specifications approved by the Department of Transportation (Division of Project Development), Department of Transportation (Office of Underground Coordination), and Department of Water Management.

This grant of privilege in the public way shall be subject to the provisions of Section 10-28-015 and all other required provisions of the Municipal Code of Chicago.

The grantee shall pay to the City of Chicago as compensation for the privilege #1119182 herein granted the sum of four hundred (\$400.00) per annum in advance.

A 25% penalty will be added for payments received after due date.

The permit holder agrees to hold the City of Chicago harmless for any damage, relocation or replacement costs associated with damage, relocation or removal of private property caused by the City performing work in the public way.

Authority herein given and granted for a period of five (5) years from and after Date of Passage.

Alderman

Brendan Reilly 42nd Ward

Handwritten scribbles or marks, possibly initials or a signature, located in the lower-left quadrant of the page.

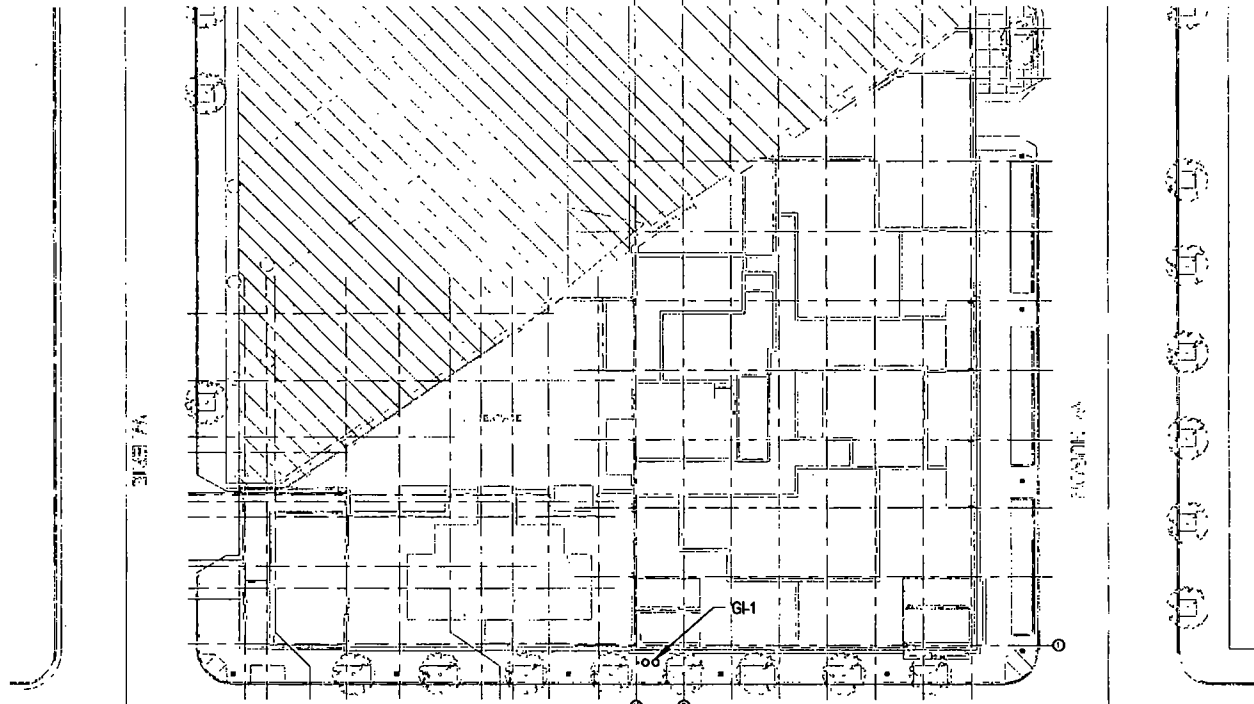

1 GI-1 SITE PLAN
NTS

GREASE INTERSEPTOR

303 W Erie, Suite 510
Chicago, Illinois 60654
office- 312 915 0557
fax- 312 915 0558
web- www.dbhms.com

PROJECT HURON & KINGSBURY		ADDRESS 676 N. KINGSBURY	
ISSUE DATE 04/10/15	SCALE 1" = 40'-0"	JOB NO 14-106	DRAWN BY Author

PSK-2

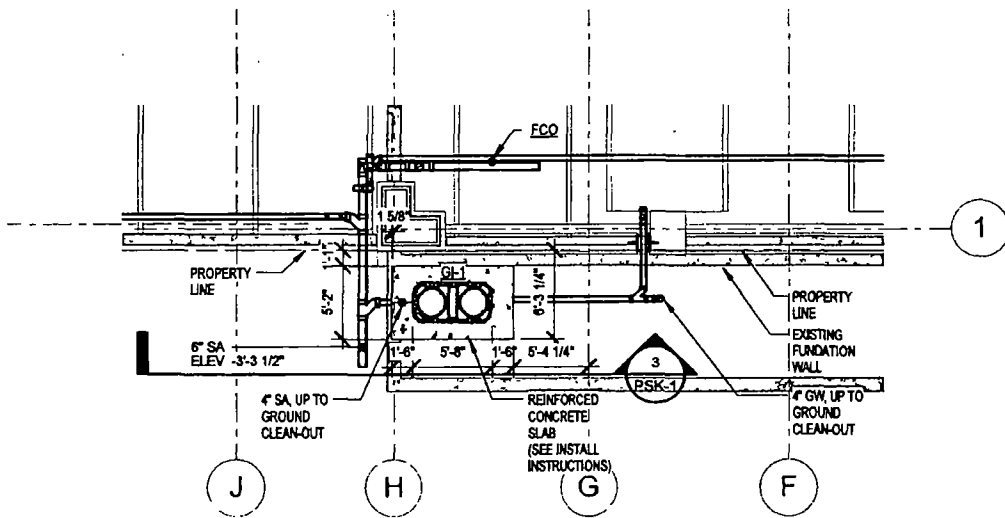

1 BASEMENT -GI-1
NTS

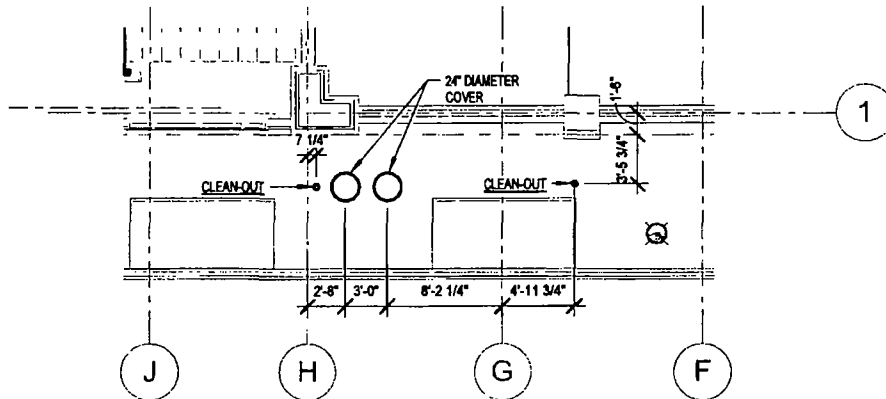

2 GI-1 FIRST FLOOR
NTS

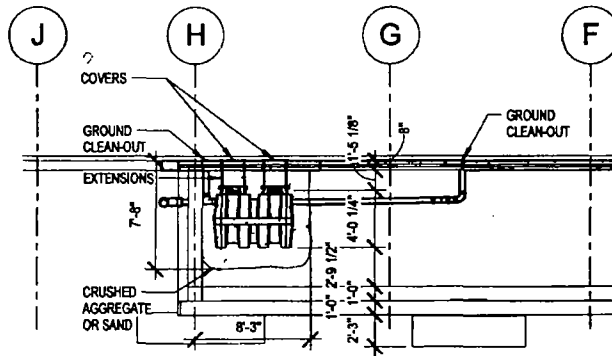

3 GI-1 SECTION
NTS



GREASE INTERCEPTOR



303 W. Erie, Suite 510
Chicago, Illinois 02954
Office: 312.815.0257
Fax: 312.815.0258
Web: www.dbhms.com

PROJECT
HURON & KINGSBURY

ISSUE DATE: 04/09/15
SCALE: 1/8" = 1'-0"
JOB NO: 14-106

ADDRESS
676 N KINGSBURY

PSK-1