



# City of Chicago



O2017-297

Office of the City Clerk

## Document Tracking Sheet

|                                 |  |
|---------------------------------|--|
| <b>Meeting Date:</b>            | 1/25/2017  |
| <b>Sponsor(s):</b>              | Moreno (1)   |
| <b>Type:</b>                    | Ordinance  |
| <b>Title:</b>                   | Grant(s) of privilege in public way for Chicago Chop Shop<br>LLC |
| <b>Committee(s) Assignment:</b> | Committee on Transportation and Public Way                       |

ORDINANCE  
CHICAGO CHOP SHOP, LLC  
Acct. No. 379152 - 1  
Permit No. 1125337

*Be It Ordained by the City Council of the City of Chicago:*

SECTION 1. Permission and authority are hereby given and granted to CHICAGO CHOP SHOP, LLC, upon the terms and subject to the conditions of this ordinance to maintain and use one (1) sign(s) projecting over the public right-of-way attached to its premises known as 2033 W. North Ave..

Said sign structure(s) measures as follows; along W. North Avenue:  
One (1) at one point five (1.5) feet in length, one point five (1.5) feet in height and eleven point six seven (11.67) feet above grade level.

The location of said privilege shall be as shown on prints kept on file with the Department of Business Affairs and Consumer Protection and the Office of the City Clerk.

Said privilege shall be constructed in accordance with plans and specifications approved by the Department of Transportation (Division of Project Development) and Zoning Department - Signs.

This grant of privilege in the public way shall be subject to the provisions of Section 10-28-015 and all other required provisions of the Municipal Code of Chicago.

The grantee shall pay to the City of Chicago as compensation for the privilege #1125337 herein granted the sum of one hundred (\$100.00) per annum in advance.

A 25% penalty will be added for payments received after due date.

The permit holder agrees to hold the City of Chicago harmless for any damage, relocation or replacement costs associated with damage, relocation or removal of private property caused by the City performing work in the public way.

Authority herein given and granted for a period of five (5) years from and after Date of Passage.

Alderman \_\_\_\_\_

  
Proto Joe Moreno 1<sup>st</sup> Ward





2333 N. Seeley Ave  
Chicago, IL 60647

312.321.8383  
sam@rightwaysigns.com

**Client**  
CHOP SHOP

**Date**  
11/13-16

**Job Address**  
2033 W North ave

**Contact Info**

**Color Palette**

Black

Matte  Gloss

Qty 1 Existing Non Illuminated 18 x 18 double sided blade sign  
Sign area 3 sq ft  
Sign weight 20 lbs  
Sign depth 7

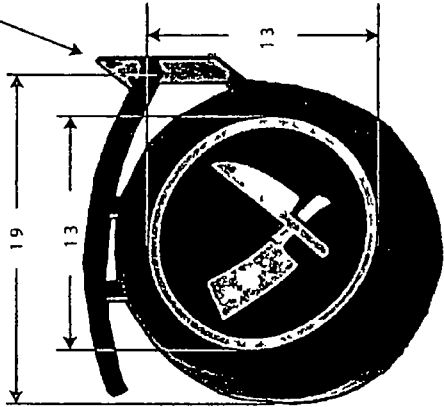

Blade attached to wall with qty 4 tapcons

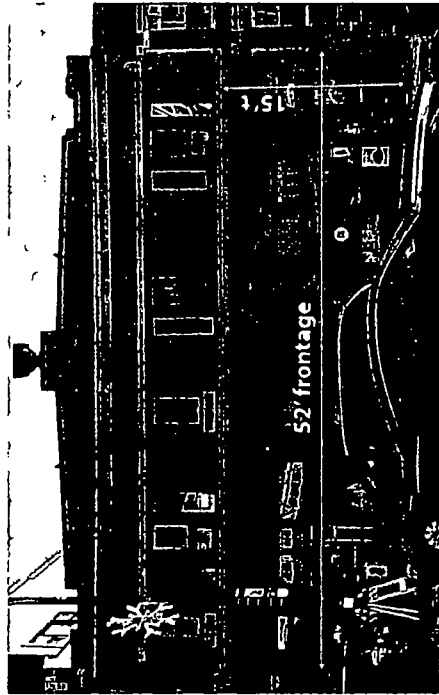
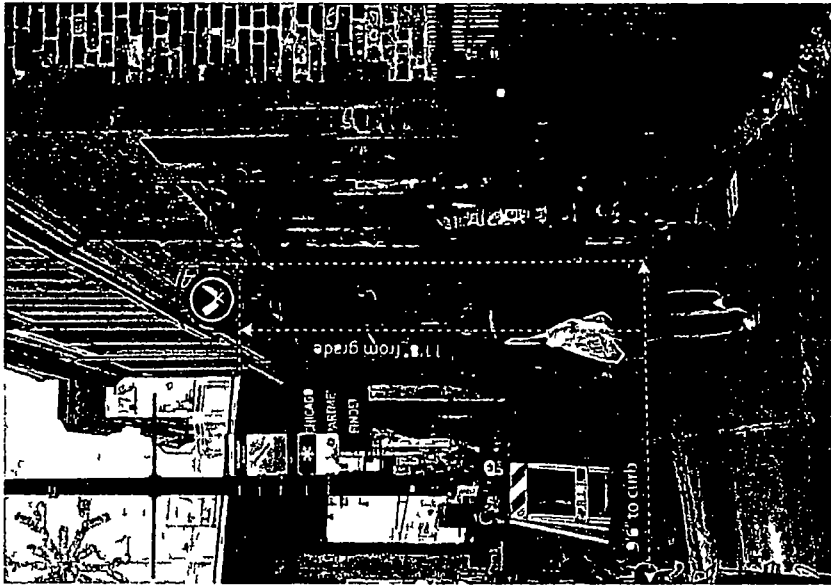

Rightway Signs LLC is not responsible for any damage or loss of property that may occur as a result of the installation of this sign. Rightway Signs LLC is not responsible for any damage or loss of property that may occur as a result of the installation of this sign.

By signing this form, the customer agrees to the terms and conditions of the sign agreement. This includes the color and finish of the sign. The customer agrees to pay for the sign and the installation of the sign.

Customer Acceptance Signature

DATE



01/25/2017

Alderman **Proco Joe Moreno**  
Ward # 01  
City of Chicago  
City Hall, Room 300  
121 North LaSalle Street  
Chicago, Illinois 60602

Re: An ordinance to use and maintain a portion of the public right-of-way for **one (1) sign(s)** for  
**CHICAGO CHOP SHOP, LLC**, adjacent to the premises known as **2033 W. North Ave.**.

Dear Alderman **Proco Joe Moreno**:

The applicant referenced above has requested the use of the public right-of-way for a **sign(s)**. An ordinance has been prepared by the Department of Business Affairs and Consumer Protection – Small Business Center - Public Way Use Unit for presentation to the City Council. Because this request was made for properties located in your ward, as approved by you as per the attached, I respectfully request that you introduce the attached ordinance at the next City Council meeting.

If you have any questions regarding this ordinance, please contact Anthony Bertuca at (312) 744-5506.

**Department of Business Affairs and Consumer Protection**