



City of Chicago



O2019-7212

Office of the City Clerk

Document Tracking Sheet

Meeting Date:	9/18/2019
Sponsor(s):	Hopkins (2)
Type:	Ordinance
Title:	Canopy(s) for Matt Cerney
Committee(s) Assignment:	Committee on Transportation and Public Way

ORDINANCE
MATT CERNEY
Acct. No. 461077 - 1
Permit No. 1141669

Be It Ordained by the City Council of the City of Chicago:

SECTION 1. Permission and authority are hereby given and granted to MATT CERNEY, upon the terms and subject to the conditions of this ordinance to maintain and use, as now constructed, one (1) Canopy(s) projecting over the public right-of-way adjacent to its premises known as 2112 W. Le Moyne St..

Said Canopy(s) at W. LE MOYNE STREET measure(s):

One (1) at thirteen point five two (13.52) feet in length, and eighteen point three three (18.33) feet in width for a total of two hundred forty-seven point eight two (247.82) square feet.

The location of said privilege shall be as shown on prints kept on file with the Department of Business Affairs and Consumer Protection and the Office of the City Clerk.

Said privilege shall be constructed in accordance with plans and specifications approved by the Zoning Department - Signs.

This grant of privilege in the public way shall be subject to the provisions of Section 10-28-015 and all other required provisions of the Municipal Code of Chicago.

The grantee shall pay to the City of Chicago as compensation for the privilege #1141669 herein granted the sum of fifty (\$50.00) per annum in advance.

A 25% penalty will be added for payments received after due date.

The permit holder agrees to hold the City of Chicago harmless for any damage, relocation or replacement costs associated with damage, relocation or removal of private property caused by the City performing work in the public way.

Authority herein given and granted for a period of five (5) years from and after Date of Passage.

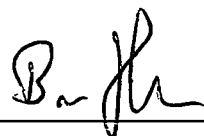
Alderman  _____
Brian Hopkins 2nd Ward

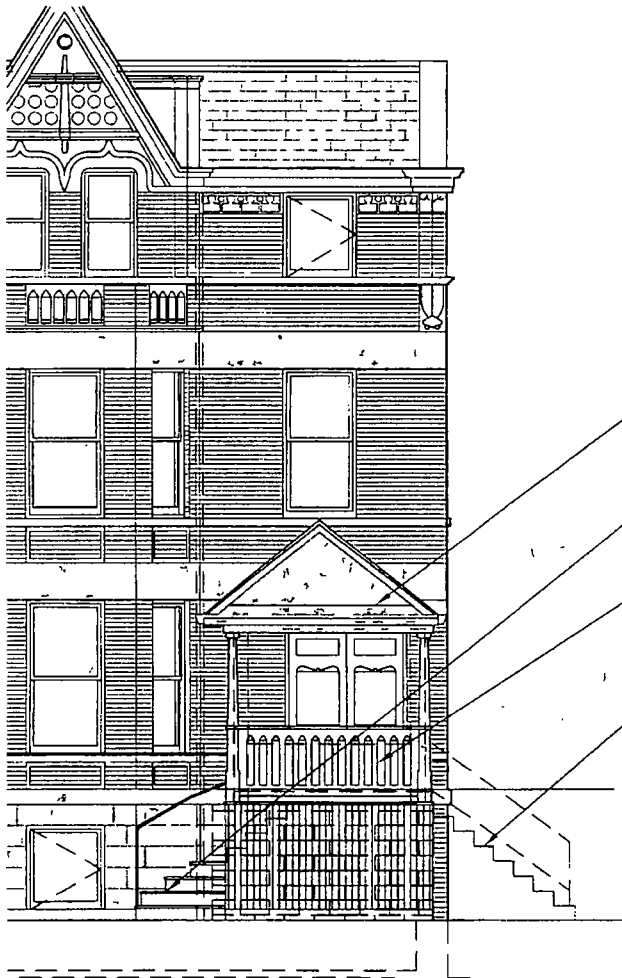
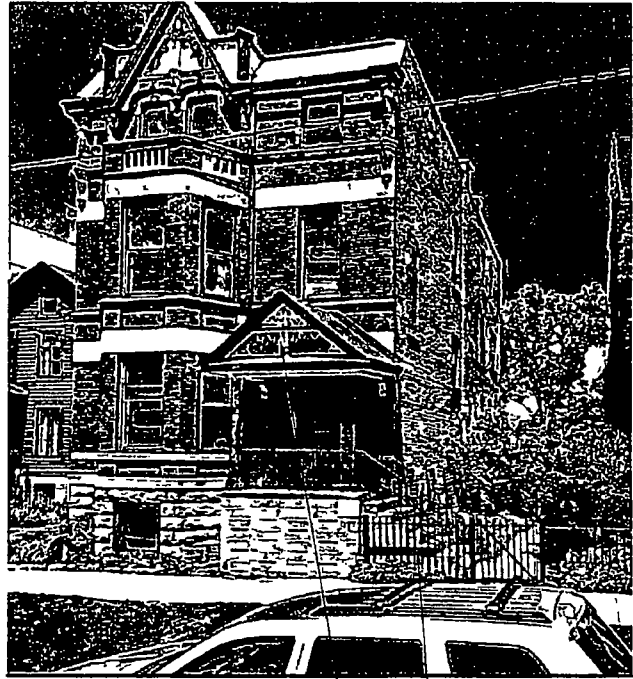
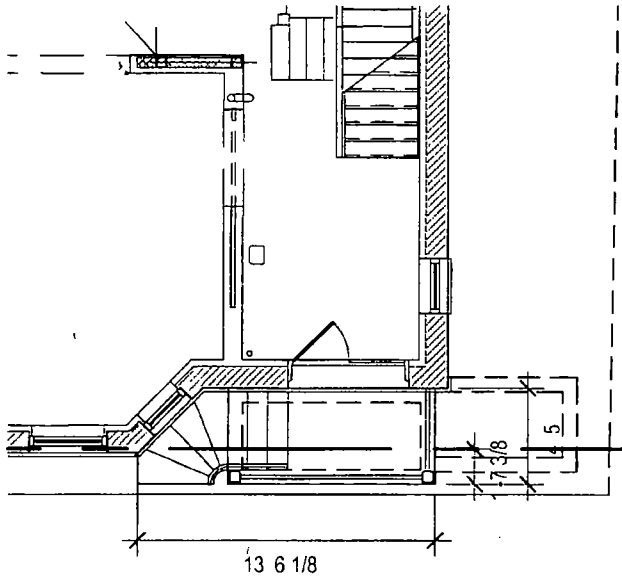

EXISTING CANOPY TO REMAIN

NEW STAIR TO MATCH HISTORIC STAIR

REPAIRED PORCH TO MATCH HISTORIC PORCH

EXISTING STAIR TO BE REMOVED





09/18/2019

Alderman Brian Hopkins
Ward # 02
City of Chicago
City Hall, Room 200
121 North LaSalle Street
Chicago, Illinois 60602

Re: An ordinance to use and maintain a portion of the public right-of-way for **one (1) canopy(ies)** for **MATT CERNEY**, adjacent to the premises known as **2112 W. Le Moyne St.**

Dear Alderman **Brian Hopkins**:

The applicant referenced above has requested the use of the public right-of-way for a **canopy(ies)**. An ordinance has been prepared by the Department of Business Affairs and Consumer Protection – Small Business Center - Public Way Use Unit for presentation to the City Council. Because this request was made for properties located in your ward, as approved by you as per the attached, I respectfully request that you introduce the attached ordinance at the next City Council meeting.

If you have any questions regarding this ordinance, please contact Anthony Bertuca at (312) 744-5506.

Department of Business Affairs and Consumer Protection