



Office of the City Clerk



O2012-7711

Office of the City Clerk

City Council Document Tracking Sheet

Meeting Date:	10/31/2012
Sponsor(s):	Waguespack, Scott (32)
Type:	Ordinance
Title:	Grant(s) of privilege in public way for Extra Space Storage
Committee(s) Assignment:	Committee on Transportation and Public Way

ORDINANCE
EXTRA SPACE STORAGE
Acct. No. 299487 - 2
Permit No. 1102499

Be It Ordained by the City Council of the City of Chicago:

SECTION 1. Permission and authority are hereby given and granted to EXTRA SPACE STORAGE, upon the terms and subject to the conditions of this ordinance to maintain and use two (2) sign(s) projecting over the public right-of-way attached to its premises known as 2100 W. Fullerton Ave..

Said sign structure(s) measures as follows; along W. Fullerton:

One (1) at forty-two point five (42.5) feet in length, four (4) feet in height and thirty-two (32) feet above grade level.

One (1) at forty point four one (40.41) feet in length, four (4) feet in height and thirty-two (32) feet above grade level.

The location of said privilege shall be as shown on prints kept on file with the Department of Business Affairs and Consumer Protection and the Office of the City Clerk.

Said privilege shall be constructed in accordance with plans and specifications approved by the Department of Transportation (Division of Project Development) and Zoning Department - Signs.

This grant of privilege in the public way shall be subject to the provisions of Section 10-28-015 and all other required provisions of the Municipal Code of Chicago.

The grantee shall pay to the City of Chicago as compensation for the privilege #1102499 herein granted the sum of six hundred (\$600.00) per annum in advance.

A 25% penalty will be added for payments received after due date.

The permit holder agrees to hold the City of Chicago harmless for any damage, relocation or replacement costs associated with damage, relocation or removal of private property caused by the City performing work in the public way.

Authority herein given and granted for a period of five (5) years from and after Date of Passage.

Alderman

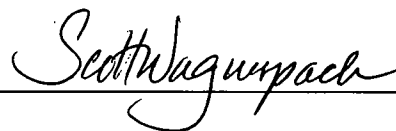

Scott Waguespack 32nd Ward

Sign 1

LED FACE LIT CHANNEL LETTER ON RACEWAY SET HORIZONTAL

SIGN 1

SIGN NAME A B SQUARE FEET

4'-0"	42'-6"	170.00
EXP-CURRM-48-DC		

ExtraSpaceStorage

EXPLODED DETAIL

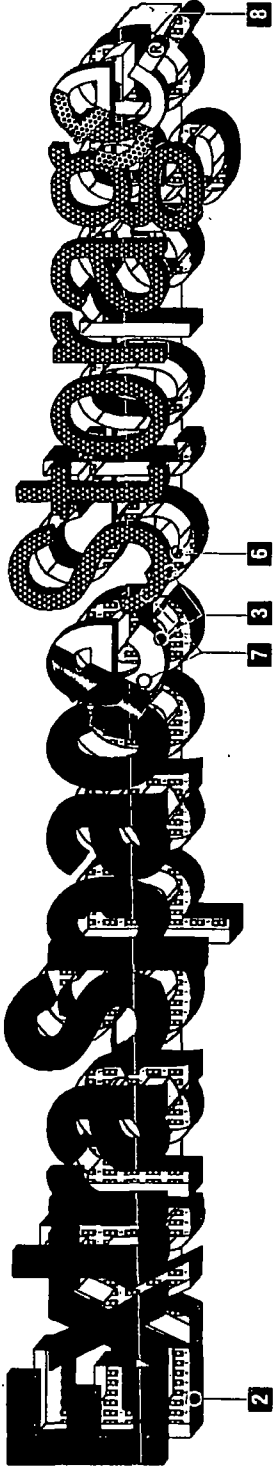

SIDE SECTION VIEW

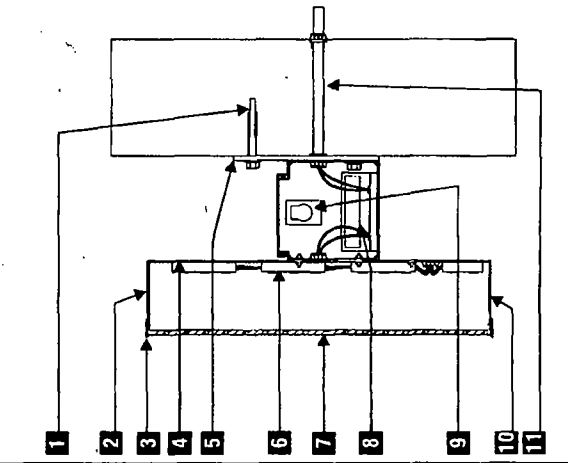

MOUNTING DETAIL

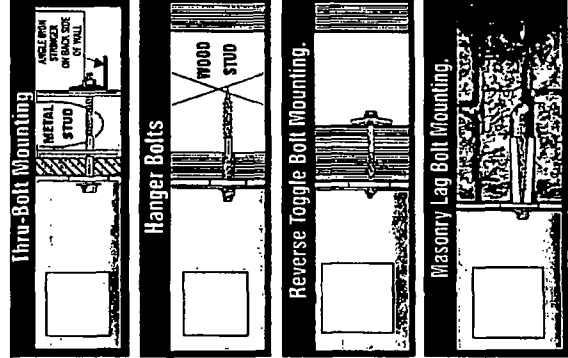

COLOR SCHEDULE

TAN	PMS #487C	#2500-05 CALON
BLUE	PMS #7483C	#2500-036 CALON
GREEN	PMS #349C	#2500-3425 CALON
WHITE		
BLACK	PMS #4402C	#2500-022 CALON

- 1 NON-CORROSIVE INSTALLATION HARDWARE. SEE DETAIL
- 2 5" FABRICATED ALUMINUM LETTER RETURNS PAINTED BLUE
- 3 1" TRIM CAP RETAINER
- 4 1" TRIM CAP RETAINER
- 5 5" FABRICATED ALUMINUM LETTER RETURNS PAINTED BLUE
- 6 1" TRIM CAP RETAINER
- 7 3/16" THICK PLEXYPOLYCARBONATE FACE WHITE WITH 1ST SURFACE GREEN TRANSLUCENT & BLACK PERE.
- 8 LOW VOLTAGE ELECTRONIC TRANSFORMER MOUNTED IN A 7 1/4" X 7 1/4" EXTRUDED .050 ALUM. RACEWAY SUPPORT/WIRING BOX PAINTED
- 9 VISIBLE CUT-OFF SWITCH WITH FLIP-UP COVER
- 10 1/2" WEEP HOLES (2) TWO PER LETTER
- 11 GROUNDING WALL PASS-THRU SEALED WATER TIGHT

Houston
Dallas

Houston Corporate Office
5525 Katy Freeway
Suite 350
Houston, TX 77007
713-977-7900
Fax 713-977-7903

Dallas Regional Office
2220 San Jacinto Blvd.
Suite 365
Denton, Texas 76205
940-380-9153
FAX: 940-380-9395

#685

Address: 2100 WEST FULLERTON AVENUE
City: CHICAGO
State: IL 60642
Account Rep: B. OSBORN
Sales Rep: K. BROWN

APPROVALS
CLIENT _____
DESIGN _____
PROD. _____

Designer: PETER CARDINAL
Design No. US182329-R5

DATE 02-29-12
Rev. Date: 05-15-12

3.7

The purchaser agrees to hold the seller harmless against any claims for action for damage which may occur as a result of cutting, planing and sanding. Inquiries for not treated in paper, use here or any other part must refer to the purchaser or seller's own technical data.

THIS DESIGN AND ENGINEERING IS SUBMITTED AS OUR PROPOSAL, AND THE RIGHT TO USE OR EXHIBIT IN ANY FORM, IS NOT AUTHORIZED WITHOUT WRITTEN PERMISSION BY US SIGNS



Department of Business Affairs and Consumer Protection
Business Assistance Center - Public Way Use Unit
City Hall - 121 N. LaSalle Street, Room 800 • Chicago, IL 60602
(312)-74-GOBIZ (312-744-6249) • (312) 744-1944 (TTY)
<http://www.cityofchicago.org/bacp>

10/31/2012

Alderman **Scott Waguespack**
Ward # **32**
City of Chicago
City Hall, Room **300**
121 North LaSalle Street
Chicago, Illinois 60602

Re: An ordinance to use and maintain a portion of the public right-of-way for **two (2) sign(s)** for **EXTRA SPACE STORAGE**, adjacent to the premises known as **2100 W. Fullerton Ave.**

Dear Alderman **Scott Waguespack**:

The applicant referenced above has requested the use of the public right-of-way for a **sign(s)**. An ordinance has been prepared by the Department of Business Affairs and Consumer Protection – Business Assistance Center - Public Way Use Unit for presentation to the City Council. Because this request was made for properties located in your ward, as approved by you as per the attached, I respectfully request that you introduce the attached ordinance at the next City Council meeting.

If you have any questions regarding this ordinance, please contact Anthony Bertuca at (312) 744-5506.

Department of Business Affairs and Consumer Protection