



City of Chicago



O2020-1788

Office of the City Clerk

Document Tracking Sheet

Meeting Date:	3/9/2020
Sponsor(s):	Villegas (36)
Type:	Ordinance
Title:	Grant(s) of privilege in public way for Multimex, Inc.
Committee(s) Assignment:	Committee on Transportation and Public Way

Direct Intro

#36

ORDINANCE
MULTIMEX, INC.
Acct. No. 395565 - 6
Permit No. 1143372

Be It Ordained by the City Council of the City of Chicago:

SECTION 1. Permission and authority are hereby given and granted to MULTIMEX, INC., upon the terms and subject to the conditions of this ordinance to maintain and use two (2) sign(s) projecting over the public right-of-way attached to its premises known as 5333 W. Fullerton Ave..

Said sign structure(s) measures as follows; along W FULLERTON AVE:

One (1) at twenty-five point two five (25.25) feet in length, three point four two (3.42) feet in height and thirteen (13) feet above grade level.

Said sign structure(s) measures as follows; along N LOREL:

One (1) at fourteen point one seven (14.17) feet in length, one point eight three (1.83) feet in height and fifteen (15) feet above grade level.

The location of said privilege shall be as shown on prints kept on file with the Department of Business Affairs and Consumer Protection and the Office of the City Clerk.

Said privilege shall be constructed in accordance with plans and specifications approved by the Department of Transportation (Division of Project Development) and Zoning Department - Signs.

This grant of privilege in the public way shall be subject to the provisions of Section 10-28-015 and all other required provisions of the Municipal Code of Chicago.

The grantee shall pay to the City of Chicago as compensation for the privilege #1143372 herein granted the sum of six hundred (\$600.00) per annum in advance.

A 25% penalty will be added for payments received after due date.

The permit holder agrees to hold the City of Chicago harmless for any damage, relocation or replacement costs associated with damage, relocation or removal of private property caused by the City performing work in the public way.

Authority herein given and granted for a period of five (5) years from and after Date of Passage.

Alderman _____

Gilbert Villegas 36th Ward

Install Channel Letters • Multimex • Chicago • IL

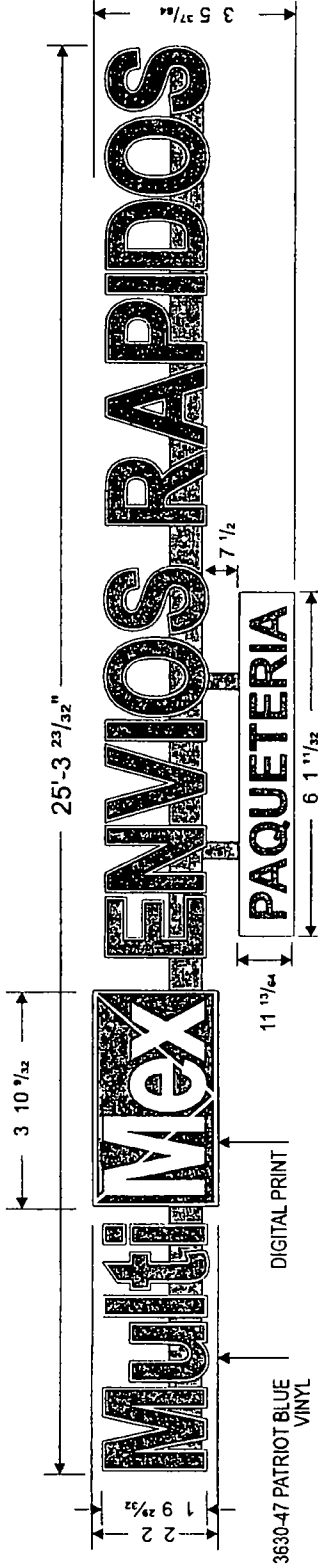

A Front-Lit, Plex-Face Channel Letters w/ LED, Raceway Mounted • Front Elevation

INTERNALLY ILLUMINATED PLASTIC FACE CHANNEL LETTERS

- QUANTITY ONE (1)
- Overall Height 39.63
- Overall Length 303.72
- Total Sq Ft 83.58 ft
- Returns Black
- Backs Black
- Trimcap Black
- Face Milk White
- First surface translucent vinyl
- 3M Series 3630-47 patriot blue vinyl
- Digital print for logo
- Raceway Painted to match back facade
- Illumination LED White
- NOTES
- WHITE interiors for increased illumination
- All paint two stage automotive acrylic

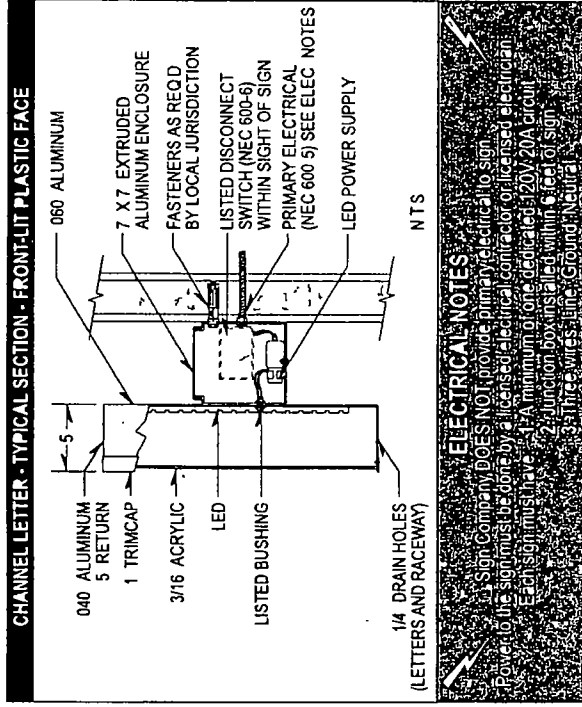

PLEASE REVIEW DRAWINGS FOR ACCURACY IN COLOR, LAYOUT, SPELLING APPROVAL STATES ALL CONTENT REPRESENTED IN THIS PROOF IS CORRECT

<p>5500 N Kedzie Ave Chicago IL 60625 773 267 6007 sales@tfa signs.com</p>	<p>Client Name MultiMex</p> <p>Location 5333 W Fullerton Ave Chicago IL</p>	<p>Start Date 10/11/2019</p> <p>Last Revision 00/00/0000</p> <p>Job# 00000</p> <p>Drawing# 00000a v1 s1 / e1</p> <p>Page 2 of 5</p>	<p>Client Approval</p> <p>Landlord Approval</p>	<p>Sales Rep Seung Park</p> <p>Designer IDV</p>
--	---	---	---	---



Department of Business Affairs and Consumer Protection
Small Business Center - Public Way Use Unit
City Hall - 121 N. LaSalle Street, Room 800 • Chicago, IL 60602
312-74-GOBIZ / 312-744-6249 • (312) 744-1944 (TTY)
<http://www.cityofchicago.org/bacp>

02/19/2020

Alderman **Gilbert Villegas**
Ward # 36
City of Chicago
City Hall, Room 200
121 North LaSalle Street
Chicago, Illinois 60602

Re: An ordinance to use and maintain a portion of the public right-of-way for **two (2) sign(s)** for
MULTIMEX, INC., adjacent to the premises known as **5333 W. Fullerton Ave.**.

Dear Alderman **Gilbert Villegas**:

The applicant referenced above has requested the use of the public right-of-way for a **sign(s)**. An ordinance has been prepared by the Department of Business Affairs and Consumer Protection – Small Business Center - Public Way Use Unit for presentation to the City Council. Because this request was made for properties located in your ward, as approved by you as per the attached, I respectfully request that you introduce the attached ordinance at the next City Council meeting.

If you have any questions regarding this ordinance, please contact Anthony Bertuca at (312) 744-5506.

Department of Business Affairs and Consumer Protection