



City of Chicago



O2013-4665

Office of the City Clerk
Document Tracking Sheet

Meeting Date:	6/5/2013
Sponsor(s):	Waguespack, Scott (32)
Type:	Ordinance
Title:	Awning(s) for New England Seafood Co. Fish Market
Committee(s) Assignment:	Committee on Transportation and Public Way

ORDINANCE
New England Seafood Company Fish Market
Acct. No. 349417 - 2
Permit No. 1098621

Be It Ordained by the City Council of the City of Chicago:

SECTION 1. Permission and authority are hereby given and granted to New England Seafood Company Fish Market, upon the terms and subject to the conditions of this ordinance to maintain and use, as now constructed, one (1) Awning(s) projecting over the public right-of-way adjacent to its premises known as 3341 N. Lincoln Ave..

Said Awning(s) at N. Lincoln measure(s):

One (1) at twenty-four (24) feet in length, and two (2) feet in width for a total of forty-eight (48) square feet.

The location of said privilege shall be as shown on prints kept on file with the Department of Business Affairs and Consumer Protection and the Office of the City Clerk.

Said privilege shall be constructed in accordance with plans and specifications approved by the Zoning Department - Signs.

This grant of privilege in the public way shall be subject to the provisions of Section 10-28-015 and all other required provisions of the Municipal Code of Chicago.

The grantee shall pay to the City of Chicago as compensation for the privilege #1098621 herein granted the sum of fifty (\$50.00) per annum in advance.

A 25% penalty will be added for payments received after due date.

The permit holder agrees to hold the City of Chicago harmless for any damage, relocation or replacement costs associated with damage, relocation or removal of private property caused by the City performing work in the public way.

Authority herein given and granted for a period of five (5) years from and after Date of Passage.

Alderman 
Scott Waguespack 32nd Ward

AWNING ON FRONT OF WALL

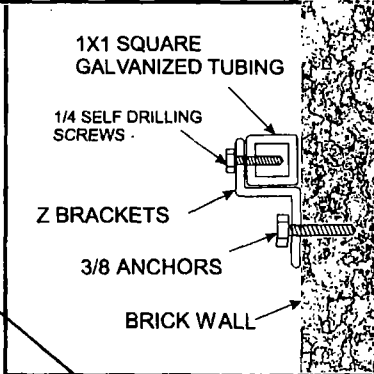

Ph: NUMBER 6"x6'
ADDRESS 6"x6'

Clips every 4' ached to wall
Top and bottom

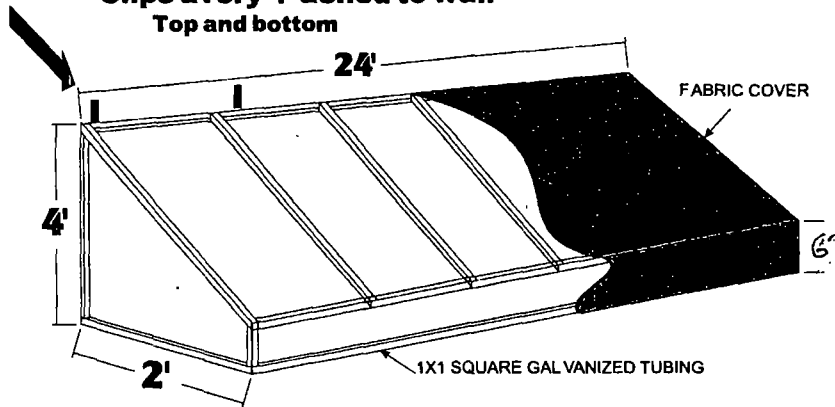

Created exclusively for _____

Address _____

City _____

State _____

Sign Location _____

Account Rep: _____

Clients Approved Date _____

Landlords Approval Date _____

DesignNo. _____ Sheet No. _____

Date _____ Rev Date _____

Designer: _____ Scale _____

WORK DESCRIPTION _____

DRAWING BY ART
DRAWING NO.



AMERICAN PUBLIC ART
773-545-2722
 3884 N. CICERO
 CHICAGO IL 60641

EMAIL APARTSIGNS @ SBCGLOBAL.NET

FAX 773-545-2701



06/05/2013

Alderman Scott Waguespack
Ward # 32
City of Chicago
City Hall, Room 300
121 North LaSalle Street
Chicago, Illinois 60602

Re: An ordinance to use and maintain a portion of the public right-of-way for **one (1) awning(s)** for **New England Seafood Company Fish Market**, adjacent to the premises known as **3341 N. Lincoln Ave.**

Dear Alderman **Scott Waguespack**:

The applicant referenced above has requested the use of the public right-of-way for a **awning(s)**. An ordinance has been prepared by the Department of Business Affairs and Consumer Protection – Business Assistance Center - Public Way Use Unit for presentation to the City Council. Because this request was made for properties located in your ward, as approved by you as per the attached, I respectfully request that you introduce the attached ordinance at the next City Council meeting.

If you have any questions regarding this ordinance, please contact Anthony Bertuca at (312) 744-5506.

Department of Business Affairs and Consumer Protection