



City of Chicago



O2015-4390

Office of the City Clerk

Document Tracking Sheet

Meeting Date:	5/20/2015
Sponsor(s):	Tunney (44)
Type:	Ordinance
Title:	Grant(s) of privilege in public way for Pompei on Sheffield
Committee(s) Assignment:	Committee on Transportation and Public Way

ORDINANCE
POMPEI ON SHEFFIELD
Acct. No. 394110 - 1
Permit No. 1118746

Be It Ordained by the City Council of the City of Chicago:

SECTION 1. Permission and authority are hereby given and granted to POMPEI ON SHEFFIELD, upon the terms and subject to the conditions of this ordinance to construct, install, maintain and use sixteen (16) Light Fixture(s) projecting over the public right-of-way adjacent to its premises known as 2955 N. Sheffield Ave..

Said Light Fixture(s) at N. Sheffield Avenue measure(s):

Eight (8) at one (1) foot in length, three (3) feet in width and fourteen (14) feet above grade level.

Said Light Fixture(s) at W. Wellington Avenue measure(s):

Eight (8) at one (1) foot in length, three (3) feet in width and fourteen (14) feet above grade level.

The location of said privilege shall be as shown on prints kept on file with the Department of Business Affairs and Consumer Protection and the Office of the City Clerk.

Said privilege shall be constructed in accordance with plans and specifications approved by the Department of Transportation (Division of Project Development).

This grant of privilege in the public way shall be subject to the provisions of Section 10-28-015 and all other required provisions of the Municipal Code of Chicago.

The grantee shall pay to the City of Chicago as compensation for the privilege #1118746 herein granted the sum of one hundred fifty (\$150.00) per annum in advance.

A 25% penalty will be added for payments received after due date.

The permit holder agrees to hold the City of Chicago harmless for any damage, relocation or replacement costs associated with damage, relocation or removal of private property caused by the City performing work in the public way.

Authority herein given and granted for a period of five (5) years from and after Date of Passage.

Alderman

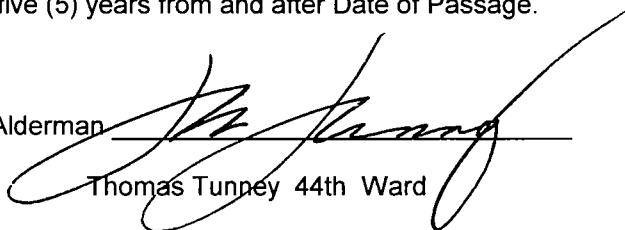

Thomas Tunney 44th Ward

SHEFFIELD ELEVATION

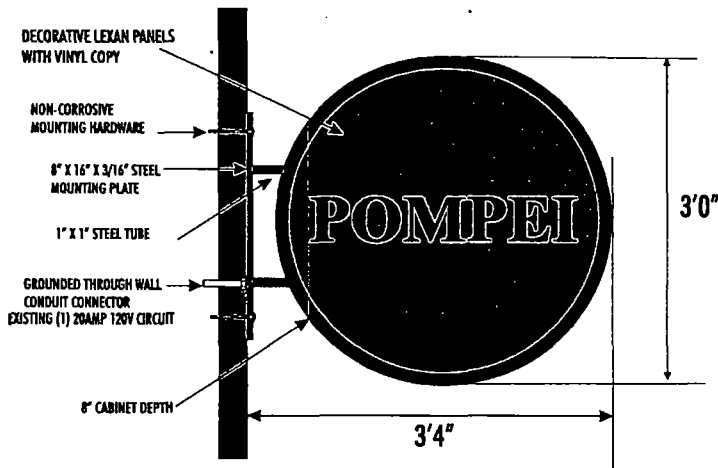
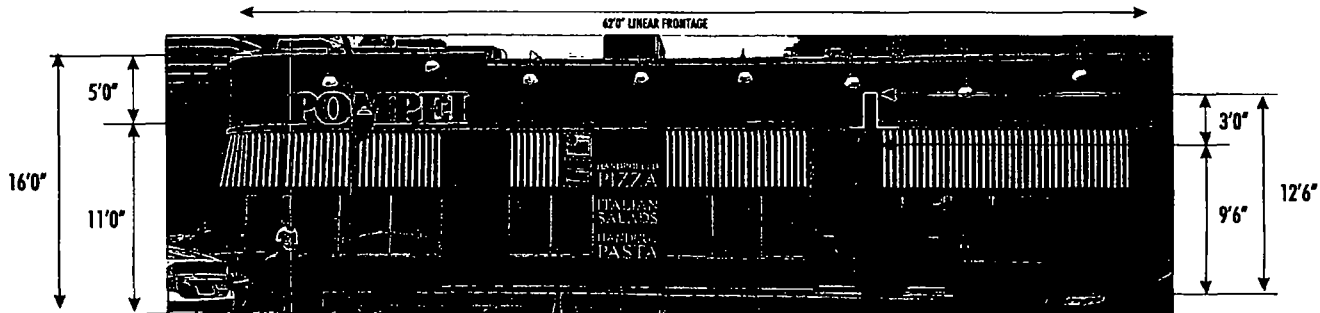

TYPICAL UL LISTED LED ILLUMINATED DOUBLE FACED CABINET LED ILLUMINATION

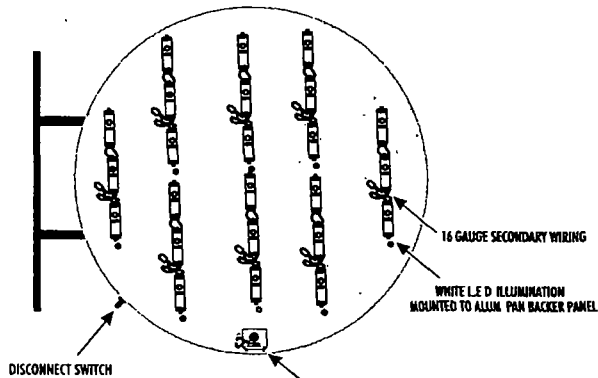

POPSIGNS
 CLASS 2 LED POWER SUPPLY
 AC INPUT 100-240 VAC
 DC OUTPUT 12V/5A/60W
 60 AMP (1) TOTAL

This is an original unpublished drawing created by Pgl Signs & Service inc. It is submitted for your approval, it is not to be shown to anyone outside of your organization, nor is it to be reproduced, copied or exhibited in any fashion. The changing of colors, sizes, materials or illumination method does not alter the design. Ownership of this design is held by Pgl signs & Service. Authorization to use this design in any fashion must be obtained in writing from Pgl signs & Service inc.
 Note: The colors depicted in print here are a graphic representation. Actual colors may vary due to printers. See color specifications.



CUSTOMER: POMPEI
 ADDRESS: 2955 N. SHEFFIELD AVE
 CHICAGO, IL 60657

DRAWING: _____
 DATE: _____
 APPROVAL: _____

www.pglsigns.com Phone: 847.298.5133 Fax: 847-298-5134
 101 N. MI. PROSPECT RD. DES PLAINES, IL 60018

SHEFFIELD ELEVATION

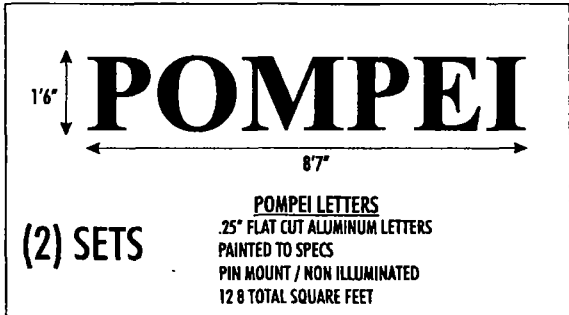
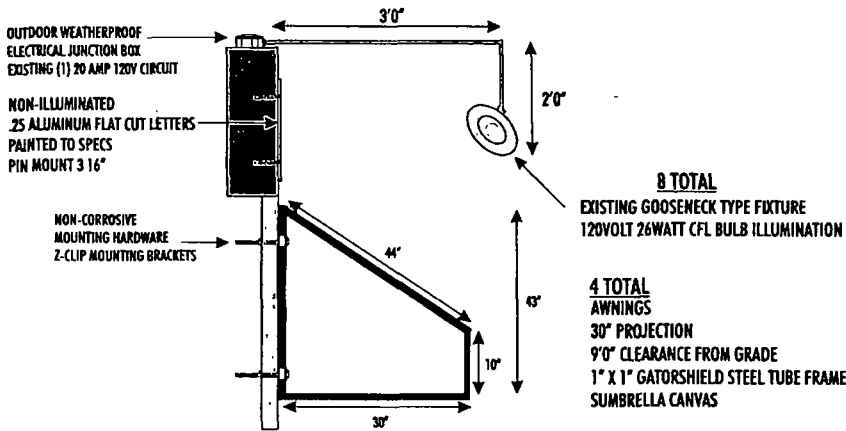
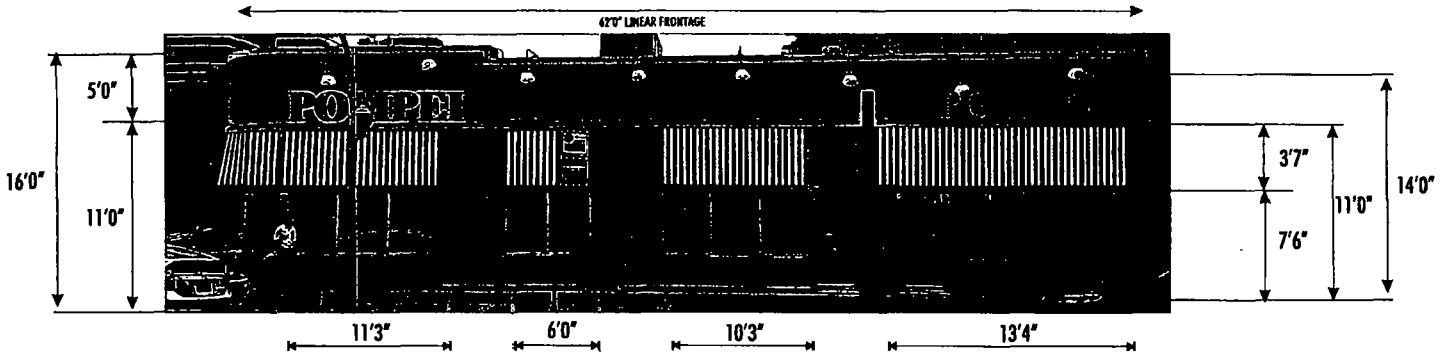

CUSTOMER: POMPEI
 ADDRESS: 2955 N. SHEFFIELD AVE
 CHICAGO, IL 60657

 DRAWING: _____
 DATE: _____
 APPROVAL: _____

 www.pgl-signs.com Phone: 847.298.5133 Fax: 847-298-5134
 461 W. 117. PROSPECT RD. DES PLAINES, IL 60016

This is an original unpublished drawing created by Pgl Signs & Service inc. It is submitted for your approval. It is not to be shown to anyone outside of your organization, nor is it to be reproduced, copied or exhibited in any fashion. The changing of colors, sizes, materials or illumination method does not alter the design. Ownership of this design is held by Pgl signs & Service. Authorization to use this design in any fashion must be obtained in writing from Pgl signs & Service inc.
 *Notice: The colors depicted in print here are a graphic representation. Actual colors may vary due to printers. See color specifications.

SHEFFIELD ELEVATION

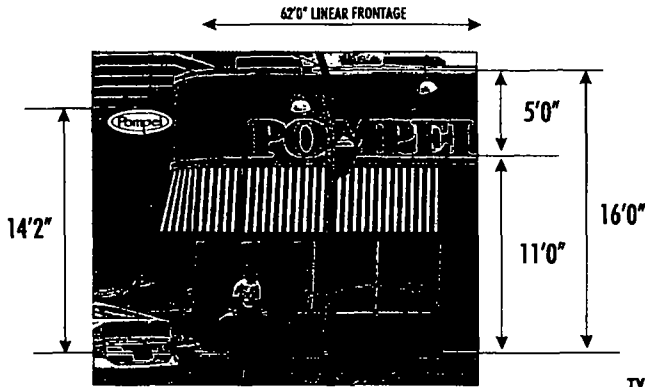

TYPICAL UL LISTED LED ILLUMINATED DOUBLE FACED CABINET LED ILLUMINATION

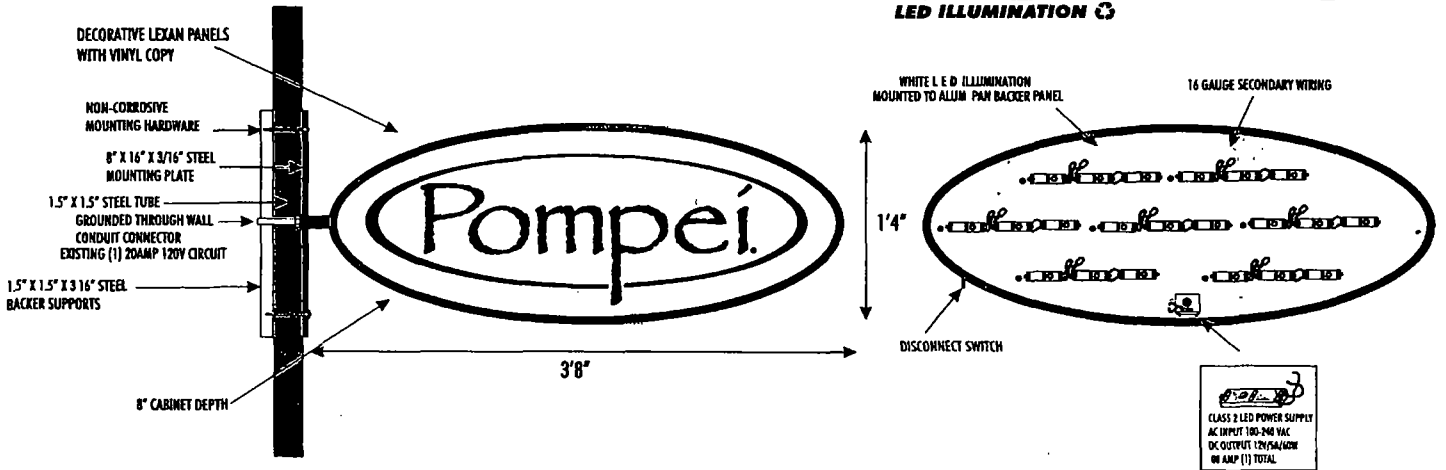

CUSTOMER: POMPEI
 ADDRESS: 2955 N. SHEFFIELD AVE
 CHICAGO, IL 60657

DRAWING: _____
 DATE: _____
 APPROVAL: _____

www.pglsgns.com Phone: 847.298.5133 Fax: 847-298-5134
 461 N. HT. PROSPECT RD. DES PLAINES, IL 60018

This is an original unpublished drawing created by Pgl Signs & Service inc. It is submitted for your approval. It is not to be shown to anyone outside of your organization, nor is it to be reproduced, copied or exhibited in any fashion. The changing of colors, sizes, materials or illumination method does not alter the design. Ownership of this design is held by Pgl signs & Service. Authorization to use this design in any fashion must be obtained in writing from Pgl signs & Service Inc.
 Note: The colors depicted in print here are a graphic representation. Actual colors may vary due to printers. See color specifications.

WELLINGTON ELEVATION

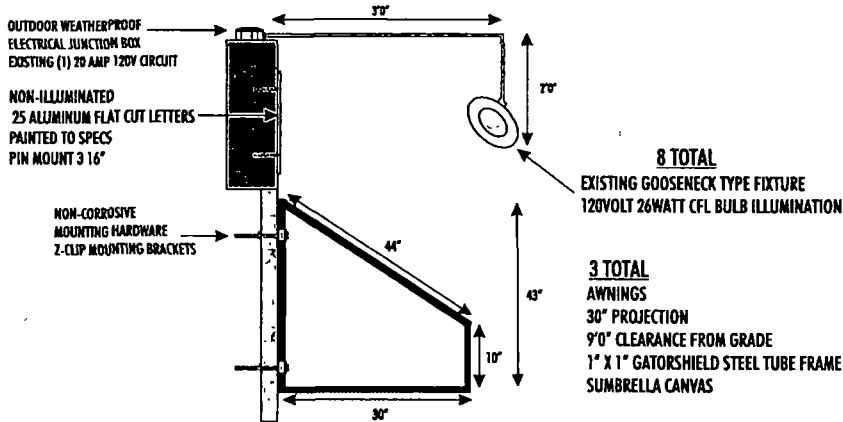
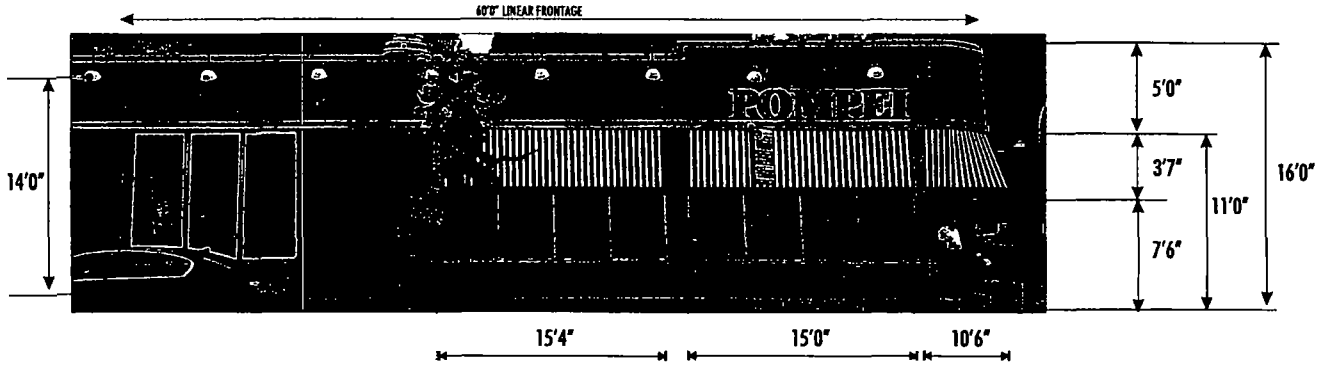

POMPEI
(1) SET

POMPEI LETTERS
 .25" FLAT CUT ALUMINUM LETTERS
 PAINTED TO SPECS
 PIN MOUNT / NON ILLUMINATED
 12.8 TOTAL SQUARE FEET



CUSTOMER: POMPEI
 ADDRESS: 2955 N. SHEFFIELD AVE.
 CHICAGO, IL 60657

DRAWING: _____
 DATE: _____
 APPROVAL: _____

www.pgisigns.com Phone: 847-298-5133 Fax: 847-298-5134
 462 N. W. PROSPECT RD. DES PLAINES, IL 60018

This is an original unpublished drawing created by PGI Signs & Service Inc. It is submitted for your approval. It is not to be shown to anyone outside of your organization, nor is it to be reproduced, copied or exhibited in any fashion. The changing of colors, sizes, materials or illumination method does not alter the design. Ownership of this design is held by PGI Signs & Service. Authorization to use this design in any fashion must be obtained in writing from PGI Signs & Service Inc.
 Note: The colors depicted in print here are a graphic representation. Actual colors may vary due to printers. See color specifications.



05/20/2015

Alderman **Thomas Tunney**
Ward # 44
City of Chicago
City Hall, Room 203
121 North LaSalle Street
Chicago, Illinois 60602

Re: An ordinance to use and maintain a portion of the public right-of-way for **sixteen (16) light fixture(s)** for **POMPEI ON SHEFFIELD**, adjacent to the premises known as **2955 N. Sheffield Ave.**.

Dear Alderman **Thomas Tunney**:

The applicant referenced above has requested the use of the public right-of-way for a **light fixture(s)**. An ordinance has been prepared by the Department of Business Affairs and Consumer Protection – Small Business Center - Public Way Use Unit for presentation to the City Council. Because this request was made for properties located in your ward, as approved by you as per the attached, I respectfully request that you introduce the attached ordinance at the next City Council meeting.

If you have any questions regarding this ordinance, please contact Anthony Bertuca at (312) 744-5506.

Department of Business Affairs and Consumer Protection