



# City of Chicago



O2021-1302

Office of the City Clerk

## Document Tracking Sheet

<b>Meeting Date:</b>	4/19/2021
<b>Sponsor(s):</b>	Tunney (44)
<b>Type:</b>	Ordinance
<b>Title:</b>	Grant(s) of privilege in public way for Sushi +
<b>Committee(s) Assignment:</b>	Committee on Transportation and Public Way

Direct Intro  
# 44

ORDINANCE  
SUSHI +  
Acct. No. 413865 - 1  
Permit No. 1142646

*Be It Ordained by the City Council of the City of Chicago:*

SECTION 1. Permission and authority are hereby given and granted to SUSHI +, upon the terms and subject to the conditions of this ordinance to maintain and use one (1) sign(s) projecting over the public right-of-way attached to its premises known as 3219 N. Broadway .

Said sign structure(s) measures as follows; along N. BROADWAY:  
One (1) at sixteen (16) feet in length, three point two five (3.25) feet in height and thirteen (13) feet above grade level.

The location of said privilege shall be as shown on prints kept on file with the Department of Business Affairs and Consumer Protection and the Office of the City Clerk.

Said privilege shall be constructed in accordance with plans and specifications approved by the Department of Transportation (Division of Project Development) and Zoning Department - Signs.

This grant of privilege in the public way shall be subject to the provisions of Section 10-28-015 and all other required provisions of the Municipal Code of Chicago.

The grantee shall pay to the City of Chicago as compensation for the privilege #1142646 herein granted the sum of three hundred (\$300.00) per annum in advance.

A 25% penalty will be added for payments received after due date.

The permit holder agrees to hold the City of Chicago harmless for any damage, relocation or replacement costs associated with damage, relocation or removal of private property caused by the City performing work in the public way.

Authority herein given and granted for a period of five (5) years from and after Date of Passage.

Alderman \_\_\_\_\_

Thomas Tunney 44<sup>th</sup> Ward

Sushi Plus Rotary Sushi Bar • Oswego • IL

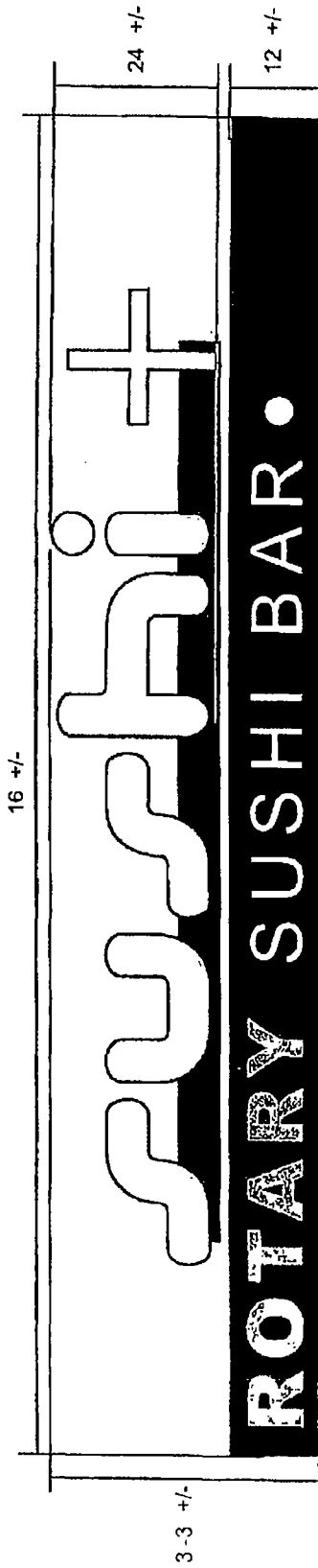

**A** Front-Lit, Plex-Face Channel Letters w/ LED, Raceway Mounted • Front View

For Production / For Presentation

**INTERNALLY ILLUMINATED PLASTIC FACE CHANNEL LETTERS**

<b>QUANTITY</b>	ONE (1)
<b>Overall Height</b>	3.3"
<b>Overall Length</b>	16.0"
<b>Total Sq Ft</b>	52.00 sq ft
<b>Returns</b>	Black COLOR
<b>Backs</b>	Black COLOR
<b>Trimcap</b>	Black
<b>Face</b>	SUSHI White / + and point over the PMS 1235C
<b>Raceway Illumination</b>	Black LED Color

**NOTES**

WHITE interiors for increased illumination  
All paint: two stage automotive acrylic

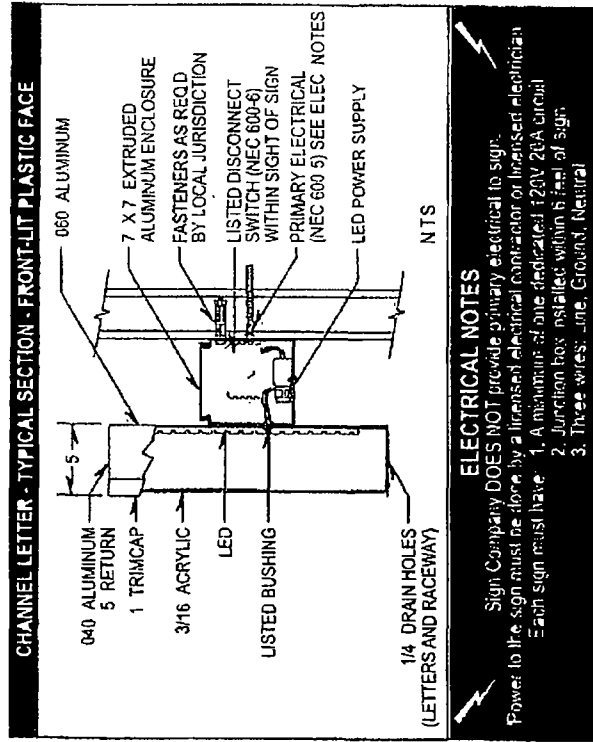

<p>5500 N. Kedzie Ave Chicago IL 60625 773-267-6007   sales@tfaesigns.com</p>	<p><b>Client Name</b> Sushi + Rotary Sushi Bar</p> <p><b>Location</b> 3219 N Broadway Ave Chicago IL 60657</p>	<p><b>Start Date</b> 09/19/2019</p> <p><b>Last Revision</b> 00/00/0000</p> <p><b>Job#</b> 00000</p> <p><b>Drawing#</b> 00000</p> <p>Page 2 of 5</p>	<p><b>Client Approval</b></p> <p><b>Landlord Approval</b></p>	<p><b>Sales Rep</b> Seung Park</p> <p><b>Designer</b> Ernesto Guevara</p>
	<p>© COPYRIGHT 2017 BY TFA SIGNS ALL DESIGNS PRESENTED ARE THE SOLE PROPERTY OF TFA SIGNS AND MAY NOT BE REPRODUCED IN PART OR WHOLE WITHOUT WRITTEN PERMISSION FROM TFA SIGNS</p>			



Department of Business Affairs and Consumer Protection  
Small Business Center - Public Way Use Unit  
City Hall - 121 N. LaSalle Street, Room 800 • Chicago, IL 60602  
312-74-GOBIZ / 312-744-6249 • (312) 744-1944 (TTY)  
<http://www.cityofchicago.org/bacp>

**03/24/2021**

**Alderman Thomas Tunney**  
Ward # 44  
City of Chicago  
City Hall, Room 300  
121 North LaSalle Street  
Chicago, Illinois 60602

Re: An ordinance to use and maintain a portion of the public right-of-way for **one (1) sign(s)** for **SUSHI** +, adjacent to the premises known as **3219 N. Broadway** .

Dear **Alderman Thomas Tunney**:

The applicant referenced above has requested the use of the public right-of-way for a **sign(s)**. An ordinance has been prepared by the Department of Business Affairs and Consumer Protection – Small Business Center - Public Way Use Unit for presentation to the City Council. Because this request was made for properties located in your ward, as approved by you as per the attached, I respectfully request that you introduce the attached ordinance at the next City Council meeting.

If you have any questions regarding this ordinance, please contact Anthony Bertuca at (312) 744-5506.

**Department of Business Affairs and Consumer Protection**