

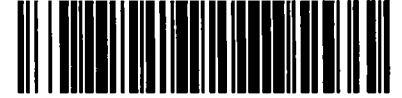

# City of Chicago



O2015-6016

Office of the City Clerk

## Document Tracking Sheet

<b>Meeting Date:</b>	7/29/2015
<b>Sponsor(s):</b>	Waguespack (32)
<b>Type:</b>	Ordinance
<b>Title:</b>	Grant(s) of privilege in public way for Bulley & Andrews
<b>Committee(s) Assignment:</b>	Committee on Transportation and Public Way

ORDINANCE  
BULLEY & ANDREWS  
Acct. No. 7450 - 1  
Permit No. 1119107

*Be It Ordained by the City Council of the City of Chicago:*

SECTION 1. Permission and authority are hereby given and granted to BULLEY & ANDREWS, upon the terms and subject to the conditions of this ordinance to construct, install, maintain and use five (5) Caisson Bells under the public right-of-way adjacent to its premises known as 1755 W. Armitage Ave..

Said Caisson Bells at N. HERMITAGE AVENUE measure(s):

One (1) at one point six seven (1.67) foot in length, and point five (.5) feet in width for a total of point eight four (.84) square feet. Said caisson bell shall be approximately thirty-two (32) feet below grade level.

One (1) at two point nine two (2.92) feet in length, and one point five eight (1.58) foot in width for a total of four point six one (4.61) square feet. Said caisson bell shall be approximately thirty-two (32) feet below grade level.

One (1) at three (3) feet in length, and one point four two (1.42) foot in width for a total of four point two six (4.26) square feet. Said caisson bell shall be approximately thirty-two (32) feet below grade level.

One (1) at two point nine two (2.92) feet in length, and one point five eight (1.58) foot in width for a total of four point six one (4.61) square feet. Said caisson bell shall be approximately thirty-two (32) feet below grade level.

One (1) at two point two five (2.25) feet in length, and one point zero eight (1.08) foot in width for a total of two point four three (2.43) square feet. Said caisson bell shall be approximately thirty-two (32) feet below grade level.

The location of said privilege shall be as shown on prints kept on file with the Department of Business Affairs and Consumer Protection and the Office of the City Clerk.

Said privilege shall be constructed in accordance with plans and specifications approved by the Department of Planning and Development and Department of Transportation (Office of Underground Coordination).

This grant of privilege in the public way shall be subject to the provisions of Section 10-28-015 and all other required provisions of the Municipal Code of Chicago.

The grantee shall pay to the City of Chicago as compensation for the privilege #1119107 herein granted the sum of four hundred (\$400.00) per annum in advance.

A 25% penalty will be added for payments received after due date.

The permit holder agrees to hold the City of Chicago harmless for any damage, relocation or replacement costs associated with damage, relocation or removal of private property caused by the City performing work in the public way.

Authority herein given and granted for a period of five (5) years from and after Date of Passage.

Alderman   
Scott Waguespack 32nd Ward

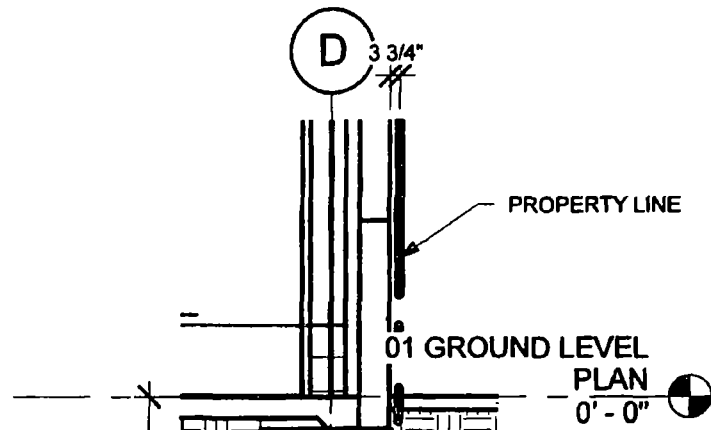

**Caisson Projections**

Caisson	X	Y
#1	6"	3'-1"
#2	1'-5"	4'-7"
#3	1'-7"	4'-8"
#4	1'-5"	4'-7"
#5	1'-2"	4'-2"

32' - 0"

2' - 2 1/4"

See "x"

See "y"

1 Section - Caisson Bell Projection  
 A2 09SK-005 3/16" = 1'-0"

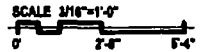

**Bulley & Andrews Headquarters**

Caisson - Public Use | ASK-005

1755 West Armitage Avenue Chicago IL 60622

05/28/15

Anbunovich Associates - Consultant  
 224 West Heron Street, Chicago IL 60654  
 Phone 312-266-1126 Fax 312-266-7123

Bulley & Andrews, LLC  
 1755 West Armitage Avenue  
 Chicago IL 60622  
 773.235.2433

NO.	DATE	DESCRIPTION
1		
2		
3		



07/29/2015

Alderman **Scott Waguespack**  
Ward # **32**  
City of Chicago  
City Hall, Room **300**  
121 North LaSalle Street  
Chicago, Illinois 60602

Re: An ordinance to use and maintain a portion of the public right-of-way for **five (5) caisson(s)** for  
**BULLEY & ANDREWS**, adjacent to the premises known as **1755 W. Armitage Ave.**

Dear Alderman **Scott Waguespack**:

The applicant referenced above has requested the use of the public right-of-way for **caisson(s)**. An ordinance has been prepared by the Department of Business Affairs and Consumer Protection– Small Business Center- Public Way Use Unit for presentation to the City Council. Because this request was made for properties located in your ward, as approved by you as per the attached, I respectfully request that you introduce the attached ordinance at the next City Council meeting.

If you have any questions regarding this ordinance, please contact Anthony Bertuca at (312) 744-5506.

**Department of Business Affairs and Consumer Protection**