



# City of Chicago



O2014-7914

Office of the City Clerk

## Document Tracking Sheet

<b>Meeting Date:</b>	9/10/2014
<b>Sponsor(s):</b>	Osterman (48)
<b>Type:</b>	Ordinance
<b>Title:</b>	Grant(s) of privilege in public way for Diana's Daycare Center LLC
<b>Committee(s) Assignment:</b>	Committee on Transportation and Public Way

ORDINANCE  
DIANA'S DAYCARE CENTER LLC  
Acct. No. 386041 - 1  
Permit No. 1113654

*Be It Ordained by the City Council of the City of Chicago:*

SECTION 1. Permission and authority are hereby given and granted to DIANA'S DAYCARE CENTER LLC, upon the terms and subject to the conditions of this ordinance to maintain and use one (1) sign(s) projecting over the public right-of-way attached to its premises known as 5961 N. Clark St..

Said sign structure(s) measures as follows; along N Clark St:  
One (1) at twelve point three four (12.34) feet in length, four (4) feet in height and fourteen (14) feet above grade level.

The location of said privilege shall be as shown on prints kept on file with the Department of Business Affairs and Consumer Protection and the Office of the City Clerk.

Said privilege shall be constructed in accordance with plans and specifications approved by the Department of Transportation (Division of Project Development) and Zoning Department - Signs.

This grant of privilege in the public way shall be subject to the provisions of Section 10-28-015 and all other required provisions of the Municipal Code of Chicago.

The grantee shall pay to the City of Chicago as compensation for the privilege #1113654 herein granted the sum of three hundred (\$300.00) per annum in advance.

A 25% penalty will be added for payments received after due date.

The permit holder agrees to hold the City of Chicago harmless for any damage, relocation or replacement costs associated with damage, relocation or removal of private property caused by the City performing work in the public way.

Authority herein given and granted for a period of five (5) years from and after Date of Passage.

Alderman \_\_\_\_\_

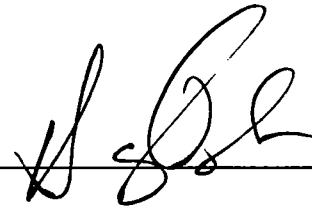

Harry Osterman 48<sup>th</sup> Ward



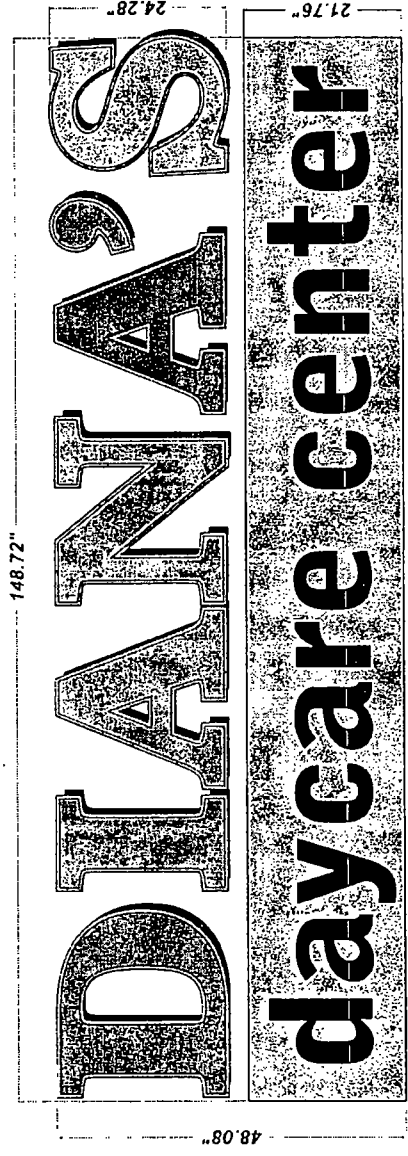

Front-Lit, Plex-Face Channel Letters, Raceway Mounted • Front View

SCALE: 0/0" = 1' 0" • For Production / For Presentation

**INTERNALLY PLASTIC FACE CHANNEL LETTERS**

**QUANTITY:** ONE (1)

**Overall Height:** 4'-0"

**Overall Length:** 0'-149"

**Total Sq.Ft.:** 49.70 ft<sup>2</sup>

**Returns:** Black

**Backs:** PMS/Wrisco COLOR

**Trimcap:** Black COLOR

**Face:** White COLOR

**First-surface translucent vinyl:**

Vinyl Manufacturer, Part # and Color

**Raceway:** PMS/PAIN # COLOR NAME

**Illumination:** LED Color

**NOTES:**

- WHITE interiors for increased illumination
- All paint two-stage automotive acrylic

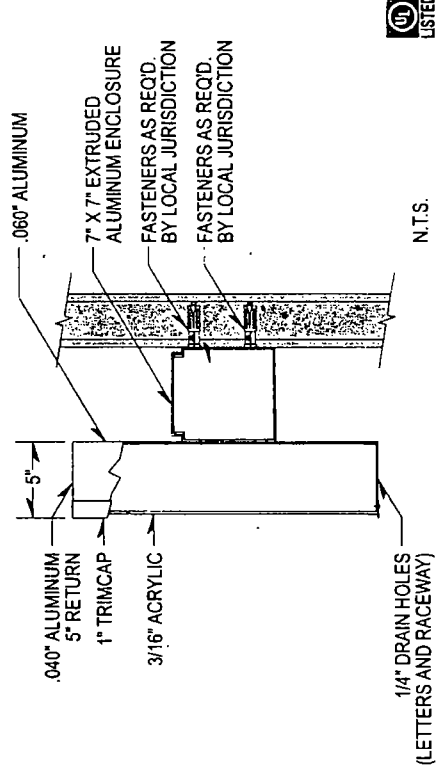

**ELECTRICAL NOTES**

1. Sign Company DOES NOT provide primary electrical design. Power to the sign must be done by a licensed electrical contractor or licensed electrician. Each sign must have:

1. A minimum of one dedicated 120V/20A circuit.
2. Junction box installed within 6 feet of sign.
3. Three wires: Line, Ground, Neutral.

N.T.S.

**UL LISTED**

**tfesigns**

5500 N. Kedzie Ave Chicago, IL 60625  
 773-267-6007 | sales@tfesigns.com

**Client Name:**  
 Diana's Day Care Center

**Location:**  
 5961 N. Clark Ave. Chicago, IL

**Start Date:** 01/16/2014  
**Last Revision:** 00/00/0000  
**Job#:** 00000  
**Drawing#:** 00000a.v1.s1 / e1  
**Page:** 1 of 2

Client Approval

Landlord Approval

**Sales Rep:** Seung  
**Designer:** Seung

MEMBER  
 INTERNATIONAL  
 FRANCHISE ASSOCIATION  
**UL LISTED**



**09/10/2014**

Alderman **Harry Osterman**  
Ward # **48**  
City of Chicago  
City Hall, Room **300**  
121 North LaSalle Street  
Chicago, Illinois 60602

Re: An ordinance to use and maintain a portion of the public right-of-way for **one (1) sign(s)** for  
**DIANA'S DAYCARE CENTER LLC**, adjacent to the premises known as **5961 N. Clark St.**

Dear Alderman **Harry Osterman**:

The applicant referenced above has requested the use of the public right-of-way for a **sign(s)**. An ordinance has been prepared by the Department of Business Affairs and Consumer Protection – Small Business Center - Public Way Use Unit for presentation to the City Council. Because this request was made for properties located in your ward, as approved by you as per the attached, I respectfully request that you introduce the attached ordinance at the next City Council meeting.

If you have any questions regarding this ordinance, please contact Anthony Bertuca at (312) 744-5506.

**Department of Business Affairs and Consumer Protection**