



# City of Chicago



O2019-1946

Office of the City Clerk

## Document Tracking Sheet

<b>Meeting Date:</b>	3/13/2019
<b>Sponsor(s):</b>	Burnett (27)
<b>Type:</b>	Ordinance
<b>Title:</b>	Awning(s) for 1550 North Clark (Chicago) Owner LLC
<b>Committee(s) Assignment:</b>	Committee on Transportation and Public Way

ORDINANCE  
1550 NORTH CLARK (CHICAGO) OWNER, LLC  
Acct. No. 416988 - 2  
Permit No. 1130291

*Be It Ordained by the City Council of the City of Chicago:*

SECTION 1. Permission and authority are hereby given and granted to 1550 NORTH CLARK (CHICAGO) OWNER, LLC, upon the terms and subject to the conditions of this ordinance to construct, install, maintain and use one (1) Awning(s) projecting over the public right-of-way adjacent to its premises known as 1549 N. Wells St.

Said Awning(s) at N WELLS ST measure(s):

One (1) at fifteen point seven five (15.75) feet in length, and five point eight three (5.83) feet in width for a total of ninety-one point eight two (91.82) square feet

The location of said privilege shall be as shown on prints kept on file with the Department of Business Affairs and Consumer Protection and the Office of the City Clerk.

Said privilege shall be constructed in accordance with plans and specifications approved by the Zoning Department - Signs.

This grant of privilege in the public way shall be subject to the provisions of Section 10-28-015 and all other required provisions of the Municipal Code of Chicago.

The grantee shall pay to the City of Chicago as compensation for the privilege #1130291 herein granted the sum of fifty (\$50.00) per annum in advance.

A 25% penalty will be added for payments received after due date.

The permit holder agrees to hold the City of Chicago harmless for any damage, relocation or replacement costs associated with damage, relocation or removal of private property caused by the City performing work in the public way

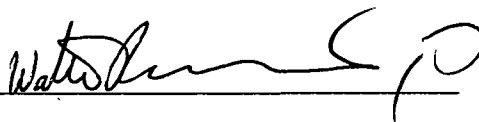

Authority herein given and granted for a period of five (5) years from and after Date of Passage.

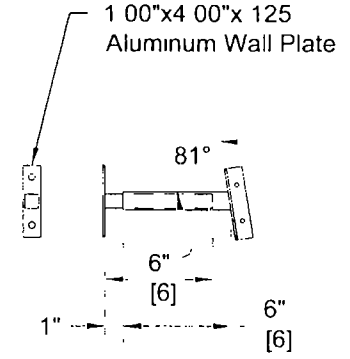
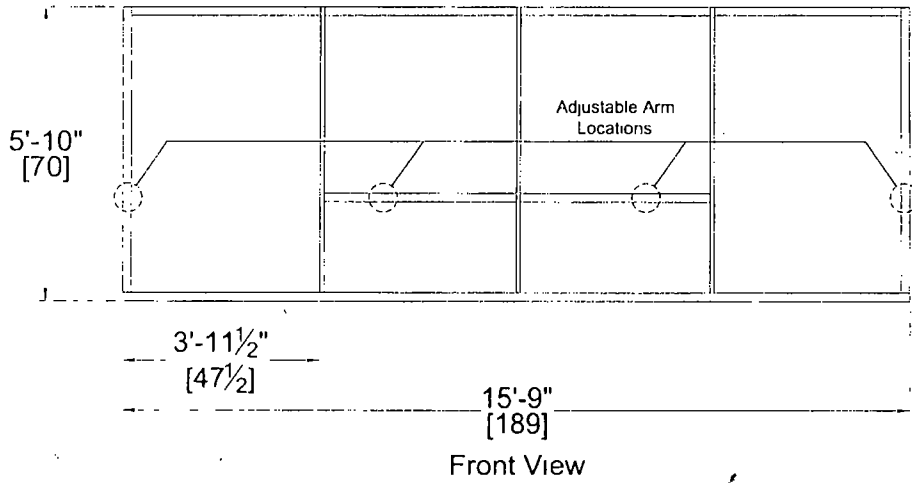
Alderman   
Walter Burnett Jr. 27th Ward



Adjustable Return Arm For Awning Qty 4

6063 T 5 1 X 1 ALUMINUM EXTRUSION  
10 WALL THICKNESS  
Properties available from Milliken Industries

-  1"x1" X 093 (MI 09) Aluminum Extrusion
-  1" X2" X 093" (MI 3) Aluminum Extrusion
-  1" X2" X 093 (MP 3) Aluminum Extrusion

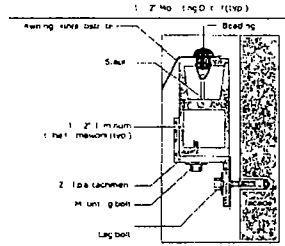

**H.M. WITT & CO.**  
**Signs**  
FINE SIGNAGE SINCE 1894

3313 West Newport Ave. Chicago, IL 60618  
tel | 773 250 5000 fax | 773 250 5100  
toll free | 1.888.427.0703 web | www.hm Witt.com

APPROVED AS IS <input type="radio"/>	<b>REVISIONS</b>	CLIENT	i550 N Clark (Chicago) Owner LLC
APPROVED W/CHANGES <input type="radio"/>		DATE	10 09-17
REVISE AND RESUBMIT <input type="radio"/>		JOB #	Awning 2
APPROVAL		DRAWN BY	bs
DATE		SCALE	No Scale
THIS IS AN ORIGINAL DRAWING BY H.M. WITT & CO. SIGNS AND IS NOT TO BE REPRODUCED WITHOUT PERMISSION OF H.M. WITT & CO. SIGNS			